

THE NEW VALUE FRONTIER



AUTOMOTIVE

Cylinder
head

Cylinder head



UM DANDIA™ tooling solutions for the automotive industry



INTRODUCTION

OPTIMUM TOOLING SOLUTIONS

KYOCERA UNIMERCO – your full-service tooling partner

KYOCERA UNIMERCO offers a complete tooling programme for machining of cylinder heads. Selection of tools is always based on a cost-benefit assessment, thus the solution often includes both standard and customised carbide and PCD tools for pre-finishing and finishing applications.

High performance tooling solutions

To machine a cylinder head at the lowest possible costs you need the best possible combination of machinery, machining parameters and tooling solutions. Therefore, we analyse all aspects of the production process involving cutting tools and systematically optimise them. Subsequently, our tool developers define the optimum tooling solution customised to fit your requirements. Often, we are able to implement a solution which reduces the number of tools necessary for a certain operation or simplify the pre-machining, thus reducing overall tooling costs and machining time considerably.

All tools are developed and manufactured utilising the latest technology, and the optimum tooling solution often includes the unique UM DANDIA™ toolholding system which helps to ensure extreme accuracy and tight tolerances. The system also allows for unsurpassed high feed rates and long tool life.

PCD tools from UM DANDIA™

UM DANDIA™ PCD tools are manufactured and re-newed in Denmark, the USA as well as in the UK.



WHY COOPERATE WITH KYOCERA UNIMERCO?

The innovative partner

In a very close partnership, we transfer the ideas/new requirements from the market into high performance PCD tooling solutions that benefit our customers in different ways. An example is the MQL solutions which were developed in close cooperation with customers and machine tool builders.

Increased product quality

The unique guide pad system and the very narrow tolerances in the KYOCERA UNIMERCO tools cause less vibrations and thus less friction. Your benefits include better roundness, more accurate coaxiality and a second-to-none surface quality of holes.

Increased productivity

Optimised geometries and tool designs made according to the actual application enable the end user to operate the UNIMERCO tools at higher rpm and feed rates. Increased cutting parameters provide a shorter cycle time, reduce friction, increase lifetime and reduce down-time. The result is greatly increased productivity.

Very short delivery time

Why wait more than 12 - 16 weeks on new tools when you can get a tooling solution designed specifically for you much faster from us? And, of course, we are able to make in-house tests, which we document in a report for you. Your tools will be delivered "ready-to-use".

Professional technical back-up

With highly qualified tooling technicians working in close cooperation with the end user, we are ready to help you find the right cutting tools and also the best complete machine environment. In other words, we optimise the tool performance until you get the expected output.

Not only regrinding but "RE-NEW"

We regrind your tools with the same attention to detail as when we manufacture new tools. Original tool geometries are secured in our RE-NEW® process. We also RE-NEW® other tool brands with very good results - often better than when you received the new tool.

100% repeatability

But of course not even KYOCERA UNIMERCO tools can run forever. Due to a unique internally developed norm system and a highly developed drawing database, we are able to continuously deliver cutting tools with the exact same geometries throughout all future deliveries, regardless of the place of production within KYOCERA UNIMERCO.



State-of-the-art tools

KYOCERA UNIMERCO constantly strives to reduce customer unit costs by means of developing ground-breaking tooling solutions.

OPTIMISATION IN THE AUTOMOTIVE INDUSTRY

LASH ADJUSTER

n = 10.000 rpm
f = 4.000 mm/min.



DIESEL INJECTION

① n = 10.000 rpm
f = 3.000 mm/min.

② n = 6.200 Rpm
f = 930 mm/min.

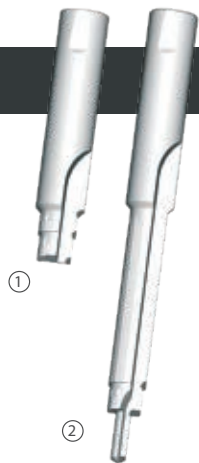

CAM CAP HOLES

n = 10.000 rpm
f = 3.000 mm/min.

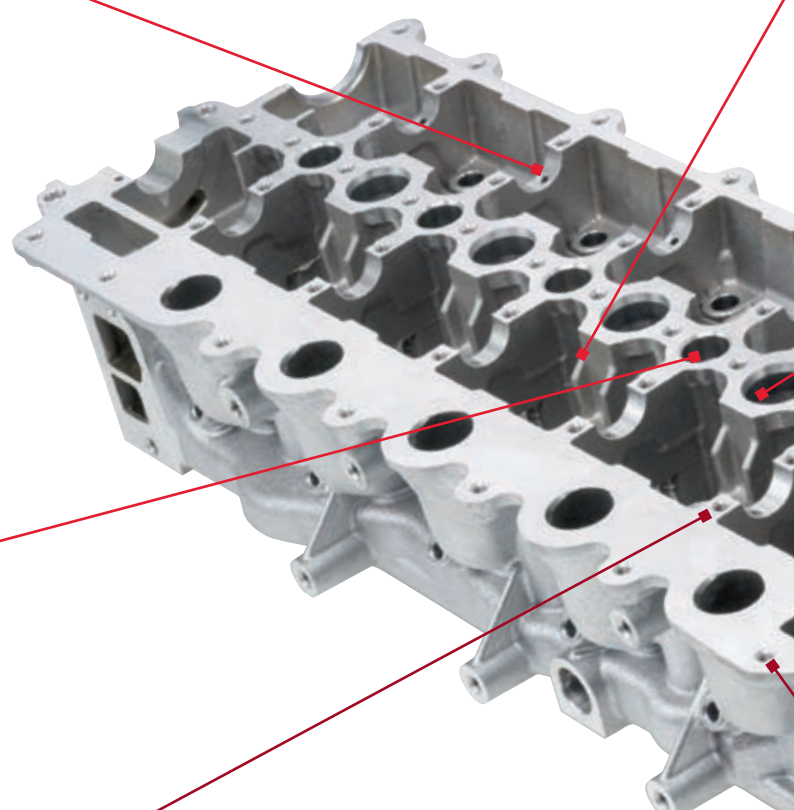

SPRING PLATFORM

- ① n = 10.000 Rpm
f = 2.500 mm/min.
- ② Nn = 15.000 Rpm
f = 3.600 mm/min.
- ③ n = 10.000 Rpm
f = 4.000 mm/min.

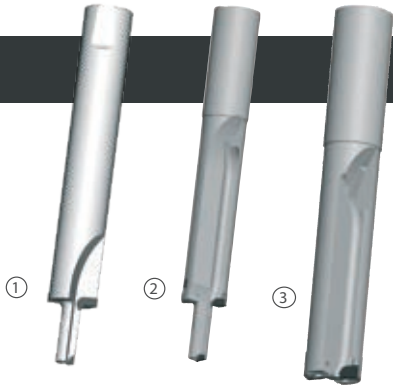

SPARK PLUG "ONE-SHOT"

- ① n = 10.000 Rpm
f = 3.000 mm/min.



MOUNTING HOLE/SPOT FACING

- n = 15.000 Rpm
f = 3.600 mm/min.



PIN BORE

- n = 15.000 Rpm
f = 8.000 mm/min.



CAM BORE

- n = 15.000 Rpm
f = 9.000 mm/min.

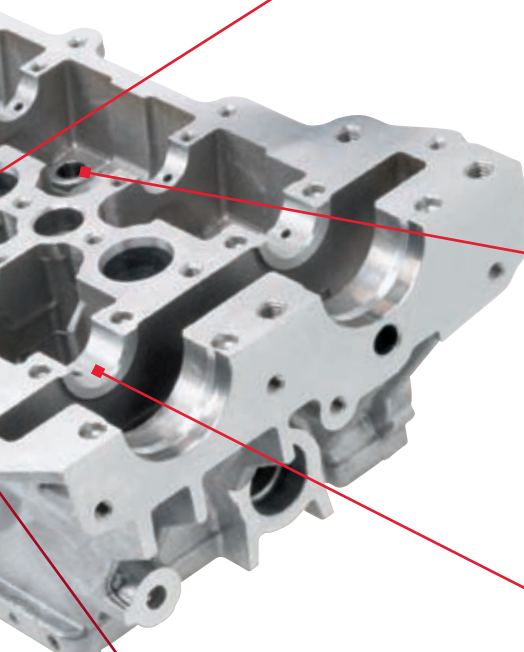

UM DANDIA™ – OPTIMUM SOLUTIONS

SEAT & GUIDE PARENT METAL

- ① n = 10.000 Rpm
f = 4.000 mm/min.
- ② n = 15.000 Rpm
f = 12.000 mm/min.

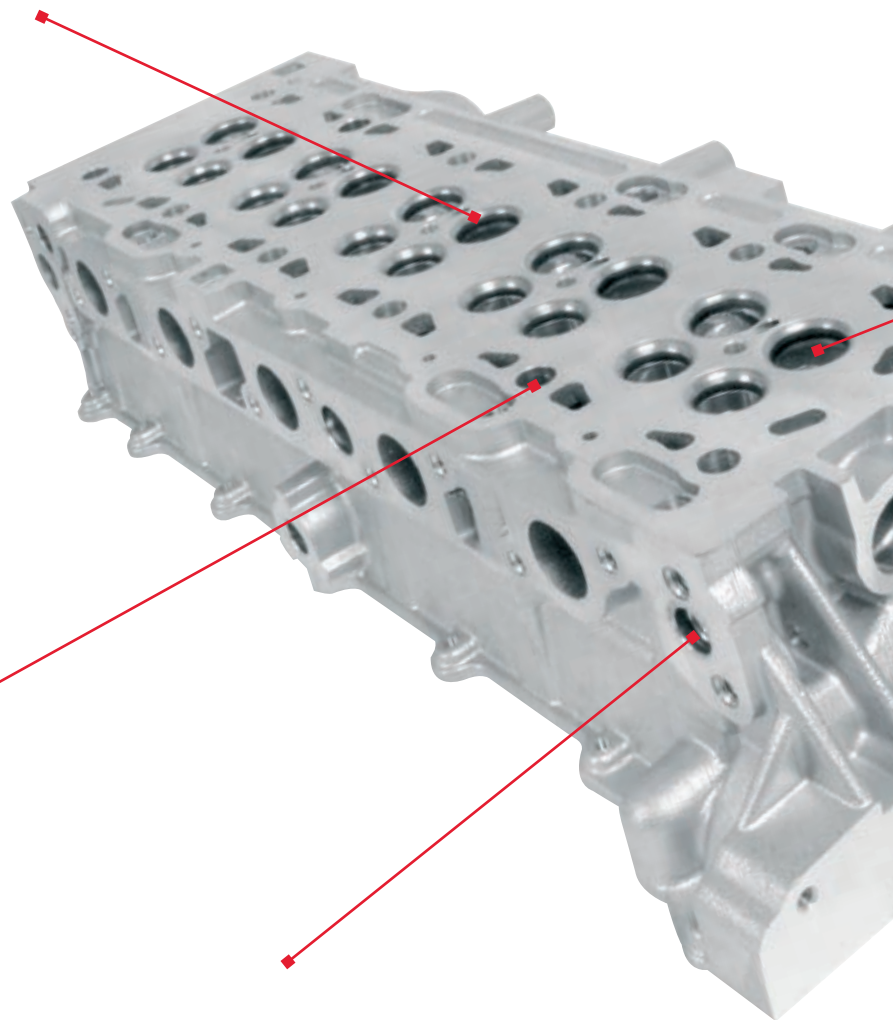
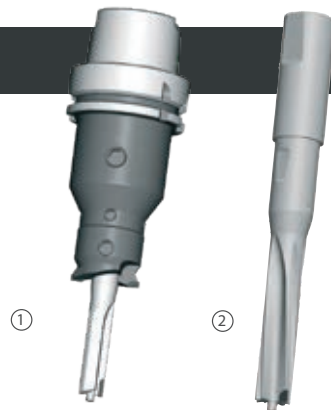

MOUNTING HOLE

n = 15.000 Rpm
f = 9.000 mm/min.



INDEX HOLE / ZERO POINT CLAMPING

n = 15.000 Rpm
f = 3.000 mm/min.



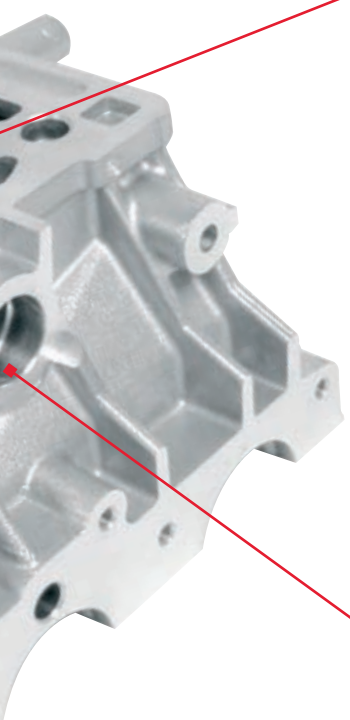

SEAT & GUIDE PARENT METAL

- ① $n = 10.000 \text{ Rpm}$
 $f = 4500 \text{ mm/min.}$
- ② $n = 15.000 \text{ Rpm}$
 $f = 8.000 \text{ mm/min.}$

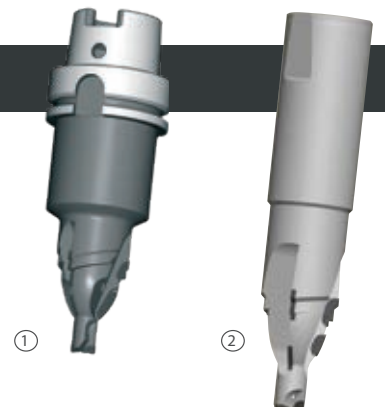

MISC. HOLES

- ① $n = 10.000 \text{ Rpm}$
 $f = 3.000 \text{ mm/min.}$
- ② $n = 14.000 \text{ Rpm}$
 $f = 3.500 \text{ mm/min.}$

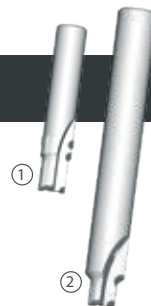

WATER CONNECTION

- ① $n = 15.000 \text{ Rpm}$
 $f = 3.600 \text{ mm/min.}$
- ② $n = 5.000 \text{ Rpm}$
 $f = 1.800 \text{ mm/min.}$
- ③ $n = 10.000 \text{ Rpm}$
 $f = 3.600 \text{ mm/min.}$

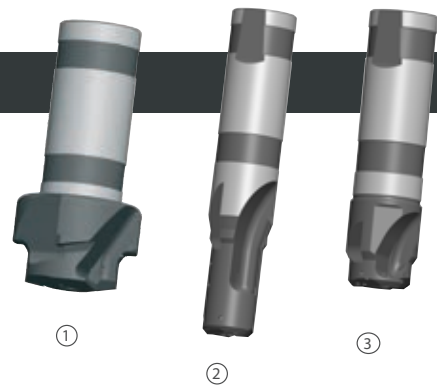

UM DANDIA – EXAMPLE APPLICATIONS

SPARK PLUG ON SHOT DRILL



CFS PCD step drill

Objective:

Reduction of machining time by using fewer tools than the 3 tools that were used previously. The hole is made in solid material (no precasting). This makes it a great challenge for a one shot solution, since the large amount of chips often results in a surface finish worse than the Rz 6.3 required.

Unimerco tool solution:

CFS PCD step drill on solid carbide tool body with sandwich drill point.

Adjustable UM DANDIA™ toolholder to ensure optimum runout.

Tool no.: 210800/000005

Result:

By implementing a CFS tool, the hole is successfully machined with a one shot solution, achieving a surface finish of Rz 1. This is possible because the CFS feature ensures that the chips do not get in contact with the hole surface.

The machining time is dramatically reduced. Using 1 tool instead of 3 eliminates 2 tool changes, 2x4 positionings, as well as 2x4 counterboring and reaming processes.

ACHIEVEMENTS

- › 1 tool replacing 3 tools
- › 33.8 seconds saved per cylinder head (478 hours/year)

DATA

- › 10,000 rpm
- › 3,000 mm/min. feed rate
- › Tool life 150,000 holes
- › Tool costs = 0.06 euro/cylinder head

- › Grob twispindle machining centre
 - › 40 bar internal coolant
 - › 10% emulsion
- Material : ALSi9Mg**

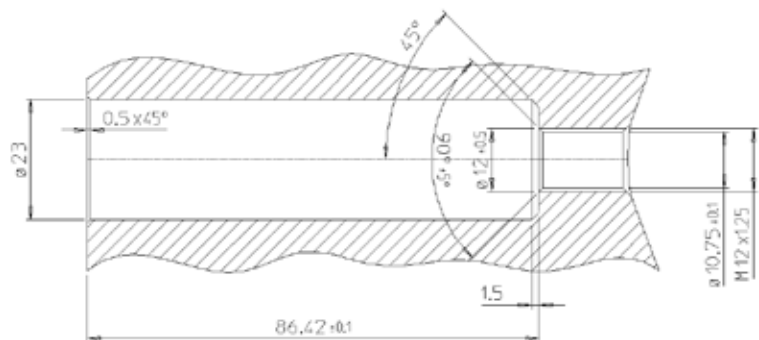

VALVE PARENT METAL FINISHING



PCD combination tool

Objective:

Reduction of cycle time. The customer previously used the same tool but with a straight-fluted reamer with no coolant outlets to the guide pads. The aim was a feed rate between 6 and 10 m/min. The straight-fluted reamer achieved a feed rate of 2.4 m/min.

Unimerco tool solution:

PCD combination reamer in adjustable UM Dandia tool-holder. The reamer has negative spiral and cutting geometry.

All chips are blown forward by the internal coolant. There are additional coolant outlets to the guide pads.

Tool no.: 710098/000491 – 492.

Result:

Feed rate for the reamer was increased by a factor of 3.3 from Vf 2,400 mm/min. to Vf 8,000 mm/min., both running at 10,000 rpm. Diameter tolerance is extremely steady, and roundness is within 4 micron.

The increase of cutting data lead to a noticeable reduction of machining time, maintaining the same tool life.

ACHIEVEMENTS

- › Feed rate increased by a factor of 3.3
- › 4.2 seconds saved per cylinder head (51 hours/year)

DATA

- › 10,000 rpm
- › 8,000 mm/min. feed rate
- Counterbore: 2,500 mm/min. feed rate
- › Tool life 300,000 holes
- › Tool costs = 0.01 euro/cylinder head

- › Machining centre
 - › 50 bar internal coolant
 - › 9% emulsion
- Material : ALSi10MgCu

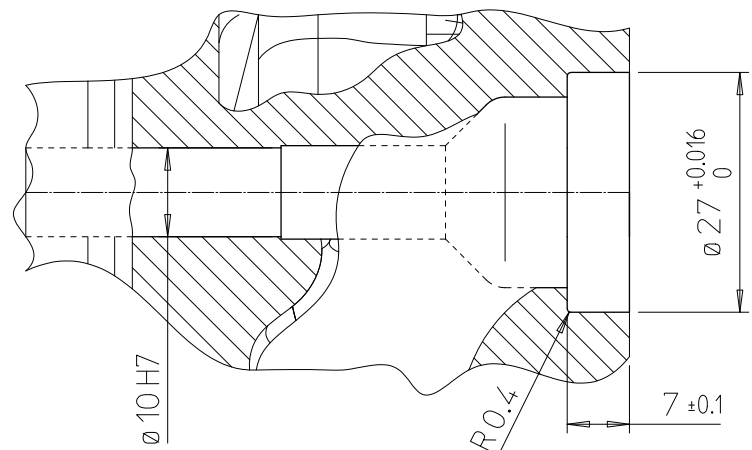

MOUNTING HOLE



PCD drill

Objective:

Increase capacity on an existing production line by reducing cycle time.

The potential saving for the mounting holes was relatively big, as each of the 8 holes has a drilling depth of 96,5 mm. The holes are drilled from solid material (no precasting pilot hole).

Unimerco tool solution:

PCD spiral-fluted drill on solid carbide tool body with sandwich drill point.

Adjustable UM DANDIA™ tool holder to ensure optimum run out

Tool no.: 210400/000030

Result:

The feed rate was increased to a remarkable 9,000 mm/min. at 15,000 rpm. This is 3.6 times faster than the previous carbide drill which performed 2,500 mm/min. at 8,000 rpm.

Even at these data, the process reliability is good. The ongoing tool costs are slightly higher than those of the carbide drill, but the savings from the reduced cycle time is several times higher.

ACHIEVEMENTS

- › Feed rate increase by a factor of 3.6
- › 22.70 seconds saved per cylinder head

DATA

- › 15,000 rpm
- › 9,000 mm/min. feed rate
- › Tool life not set yet (still running)
- › Recommended cutting data:
10,000 - 15,000 rpm, f 0,6
(vf 6,000 - 9,000 mm/min.)
- › Decreased feed rate for first 8-10 mm

- › Machining centre
 - › 40 bar internal coolant
 - › 10% emulsion
- Material : ALSi9Mg

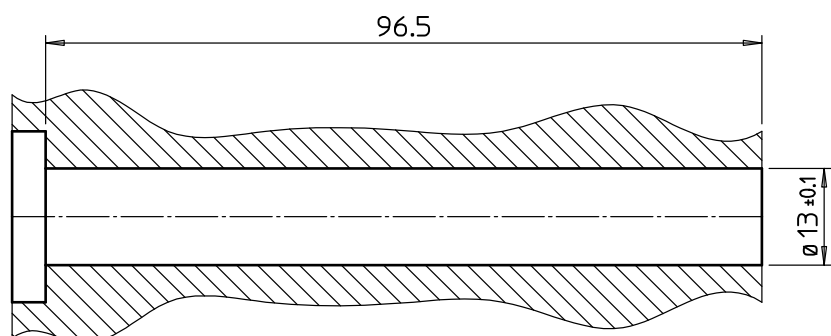

ROUGH MILLING OF CAM BORE



PCD multi mill

Objective:

To develop a cutter capable of higher feed rates and longer tool life than carbide insert cutters for the same operation. The operation involves milling from solid to half-round in one pass.

Unimerco tool solution:

PCD ball nose multi mill on steel body. The teeth are staggered with coolant supply to each tip.

The cutter can be made both as a monoblock tool, as well as with a cylindrical shank for use in a toolholder.

Tool no. example: 430233/999999.

Result:

Compared to carbide insert cutters, this tool provides superior feed rates and tool life. Feed rate is usually set at 5,000 mm/min. at 15,000 rpm.

Examples have shown tool life of 8,000 - 10,000 meters of effective material cutting.

The dimensioning stability of the machined surface is very good, which ensures good process reliability in the actual process, as well as in the following reaming process. In direct comparisons with competing cutters, Unimerco's cutters have shown 50-100% longer tool life.

LEISTUNG

- › **Erheblich verbesserte Vorschubgeschwindigkeit**
- › **Reduzierte Zykluszeit**
- › **Verbesserte Prozesssicherheit**

DATA

- › **15,000 rpm**
- › **5,000 mm/min feed rate**
- › **Tool life 8,000 - 10,000 meters of cutting (equals 10,000 twin cam 4 cylinder head**
- › **Tool costs = 0.02 euro/cylinder head**

- › **Machining centres**
 - › **Likely minimum 20 bar internal coolant**
- Material : AL castings**

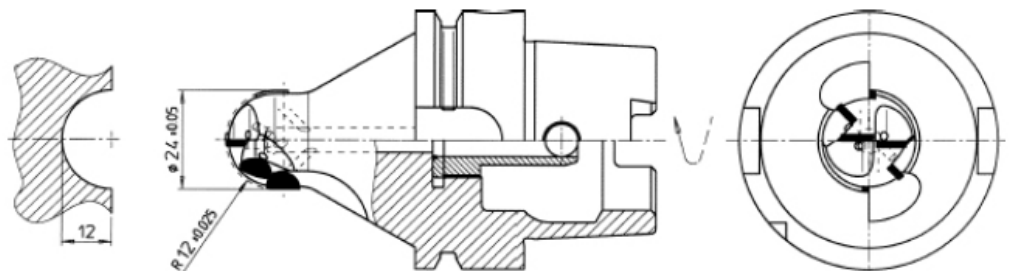

Industrial tooling solutions

Kyocera Unimerco is a global manufacturer and distributor, providing standard and customized cutting tool solutions as well as know-how and optimization guidance for the manufacturing industry.

The company was founded in 1964 and has since expanded into 17 countries, with more than 700 employees in 14 companies.

Today the company is part of the Japan-based Kyocera Corporation.

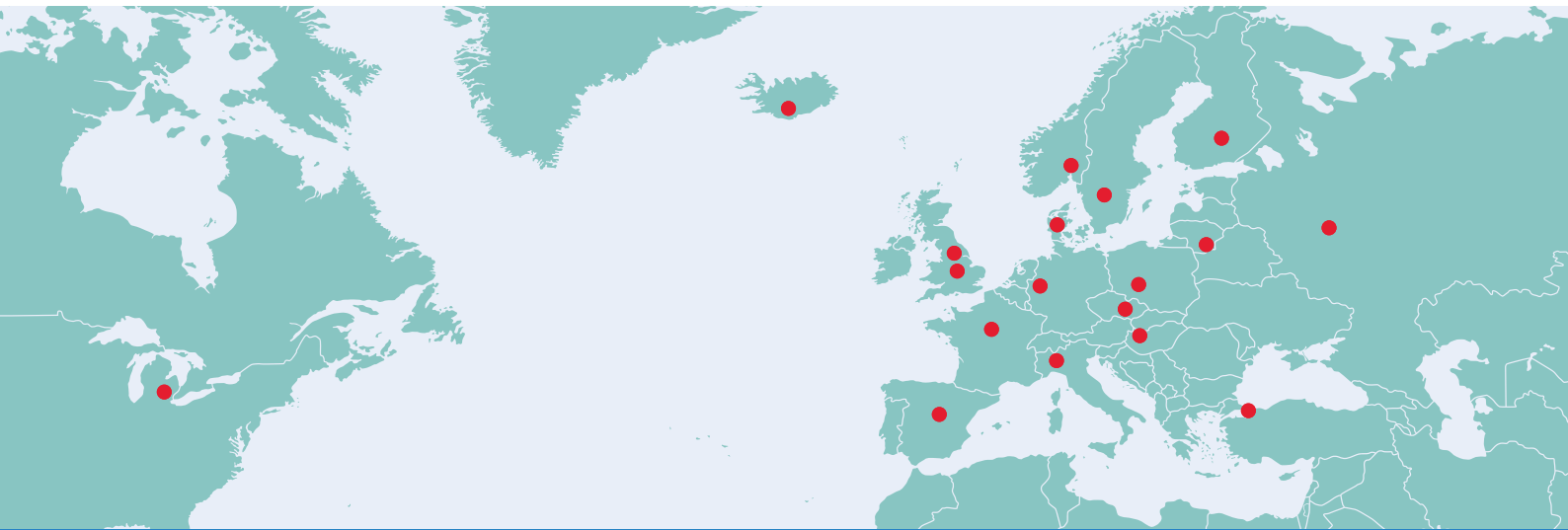

www.kyocera-unimerco.com

Tel. +45 97 14 14 11