

Tool Holder Program

Lynx 220 M/LM
 Lynx 220 LMS/LY/LSY, Lynx 2100 M/MS/LY/LSY
 Lynx 300 M, 2600 Y, Puma GT2100, 2600 M
 Lynx 2600 SY (12ST)
 Puma 2100, 2600 (II) M/MS/Y/SY (BMT55)
 Puma 2100, 2600 (II) M/MS/Y/SY (BMT65)
 Puma 2100, 2600 Y/SY, Lynx 2600 Y/SY (16ST, BMT55)
 Puma 3100 M/Y, GT3100 M
 Puma 4100, 5100 M/LM/LY
 Puma 600, 700, 800 M/LM/LY
 Puma MX1600 ST (BMT45)
 Puma MX1600, 2100 ST (BMT55)
 Puma SMX2600, 3100 ST
 Puma TT1300 SY/SYY
 Puma TT1500, 1800, 2100 MS/SY/SYY
 Puma TT2000, 2500 MS/SY

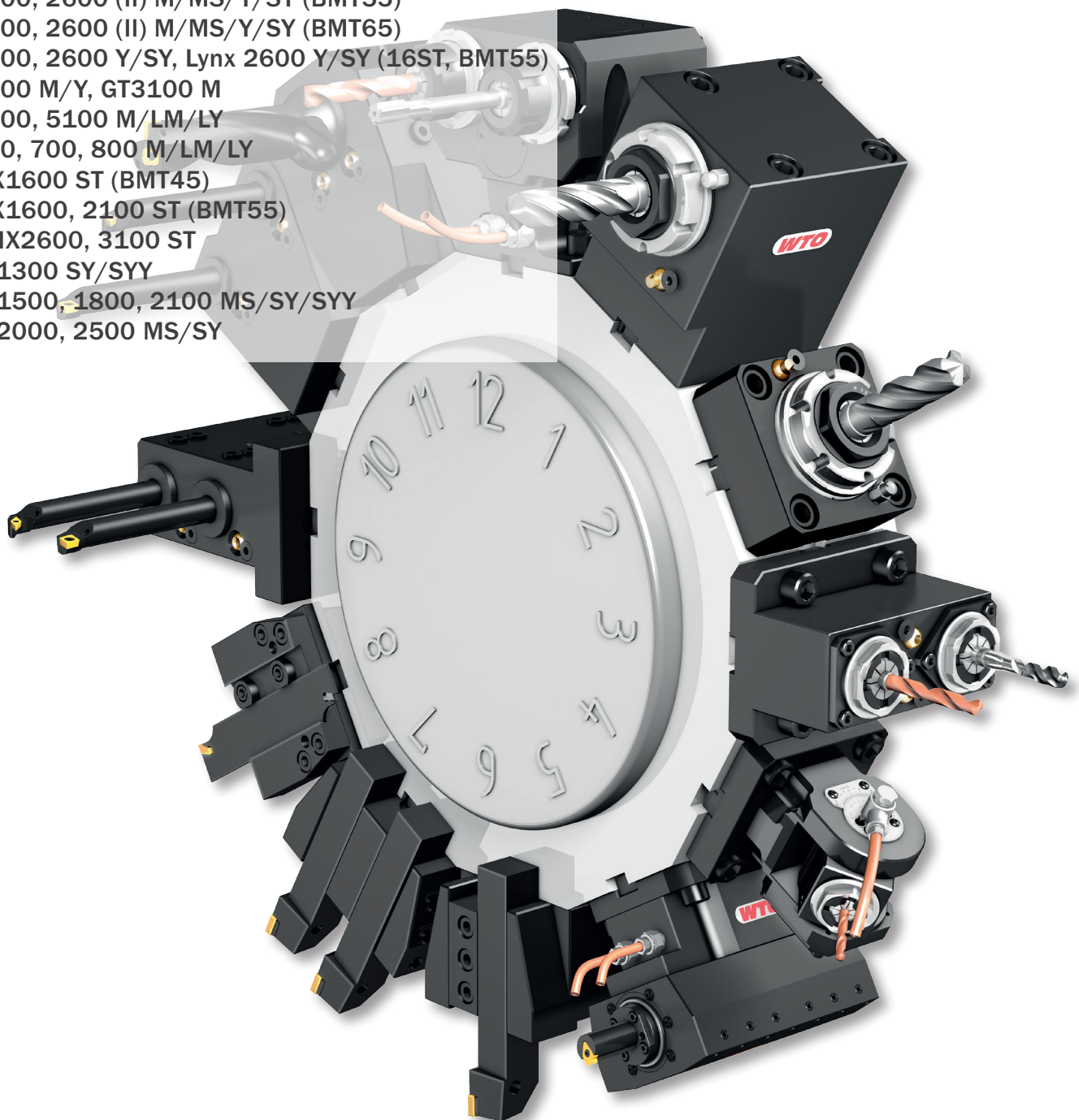

QuickFlex®

The new quick change system for high performance and precision.

Minimal investment, maximal expandability.



Designed
for
BMT Turrets

Lynx 220 M/LM	Page	4 - 6
Lynx 220 LMS/LY/LSY, Lynx 2100 M/MS/LY/LSY	Page	7 - 10
Lynx 300 M,2600 Y, Puma GT2100,2600 M	Page	11 - 13
Lynx 2600 SY (12ST)	Page	14 - 17
Puma 2100,2600(II) M/MS/Y/SY (BMT55)	Page	18 - 23
Puma 2100,2600(II) M/MS/Y/SY (BMT65)	Page	24 - 27
Puma 2100,2600 Y/SY, Lynx 2600 Y/SY (16ST, BMT55)	Page	28 - 30
Puma 3100 M/Y, GT3100 M	Page	31 - 33
Puma 4100, 5100 M/LM/LY	Page	34 - 35
Puma 600, 700, 800 M/LM/LY	Page	36 - 37
Puma MX1600 ST (BMT45)	Page	38 - 41
Puma MX1600, 2100 ST (BMT55)	Page	42 - 44
Puma SMX2600, 3100 ST	Page	45 - 48
Puma TT1300 SY/SYY	Page	49 - 51
Puma TT1500, 1800, 2100 MS/SY/SYY	Page	52 - 54
Puma TT2000, 2500 MS/SY	Page	55 - 58
Reduction sleeves	Page	59 - 60
Collets	Page	61 - 63

EC = External coolant supply
HP-IC = High pressure internal coolant supply through cutting tool
IC 80 bar = Internal and external coolant supply
 Max. coolant pressure = 80 bar
IC 30 bar = Internal and external coolant supply
 Max. coolant pressure = 30 bar
 Only use filtered coolant fluid (max. particle size = 50 µm)
 Do not run without coolant
 Do not use for machining abrasive materials such as cast iron, etc.

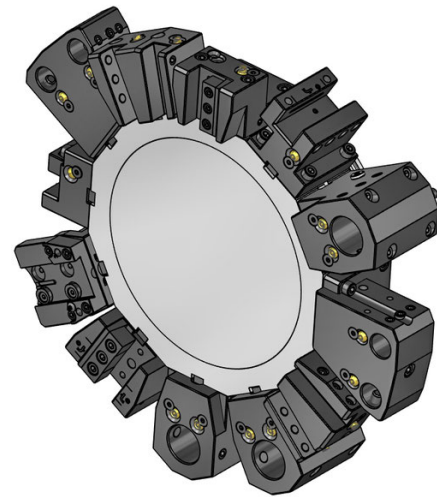
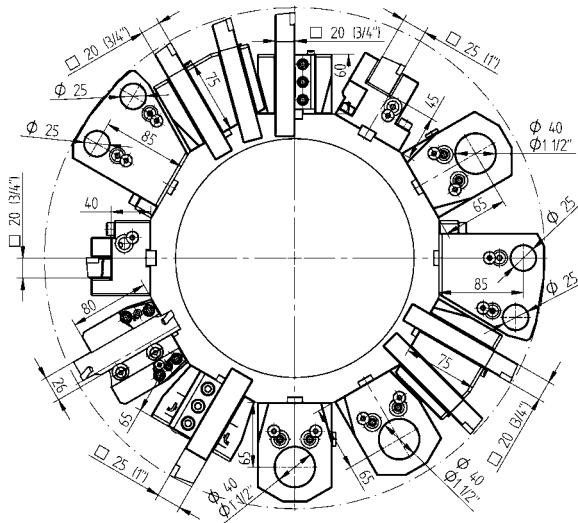

Static Toolholders - Standard Program

Static Toolholders - Enhanced Program

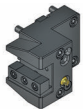

OD cutting holder

20 48-95083
3/4" 48-95084

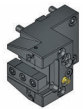

OD cutting holder, HP-IC

20 48-100605-HP IC 80 bar
25 48-104395-HP IC 80 bar
3/4" 48-108926-HP IC 80 bar
1" 48-104396-HP IC 80 bar



Face cutting holder

20 48-109148



Face cutting holder

3/4" 48-95338



Face cutting holder, HP-IC

20 48-109148-HP IC 80 bar
25 48-104397-HP IC 80 bar
3/4" 48-109149-HP IC 80 bar
1" 48-104398-HP IC 80 bar



Combination toolholder, LF=65

Ø 40 48-95090 IC 80 bar
Ø 1 1/2" 48-95327 IC 80 bar



OD cutting holder, double, 24 station

20 48-95087



Cut-off holder, adjustable

SH 26 48-94968



Cut-off holder, adjustable, HP-IC

SH 26 48-102252R IC 80 bar
SH 26 48-102252L IC 80 bar



Boring bar holder, double, 24 station

Ø 25 48-95091

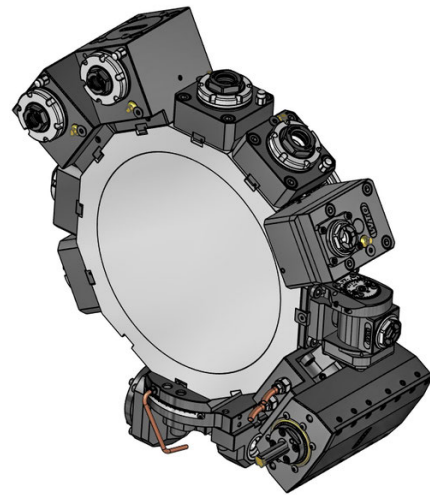
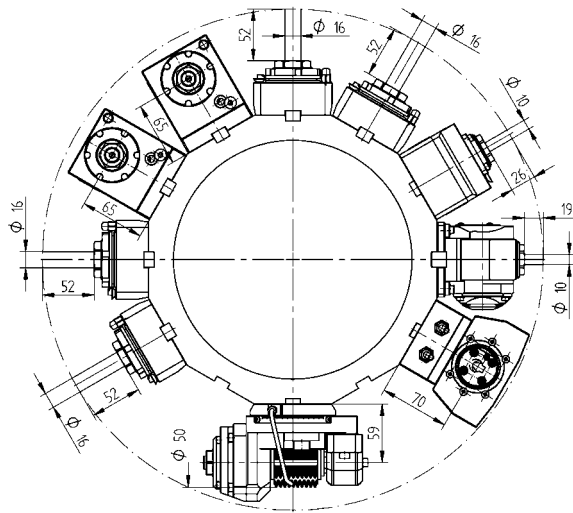

Driven Toolholders - Enhanced Program



Gear hobbing unit

Type 15-2 410900001-45 1:1 EC

-  00675001015
-  160008152 Ø 8
-  160010152 Ø 10
-  160013152 Ø 13
-  160016152 Ø 16
-  160022152 Ø 22
-  160015152 Ø 5/8"
-  160019152 Ø 3/4"
-  110587



Broaching unit for ID and OD

TN765050 414532000-45 1:1 EC

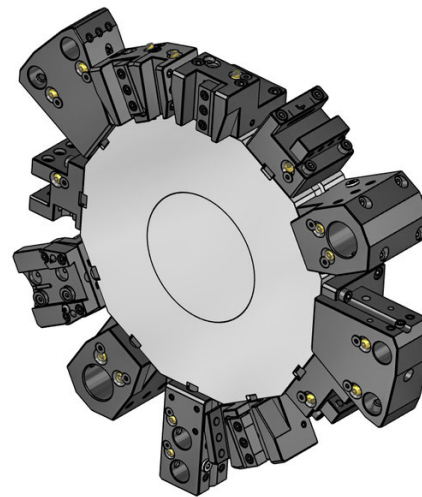
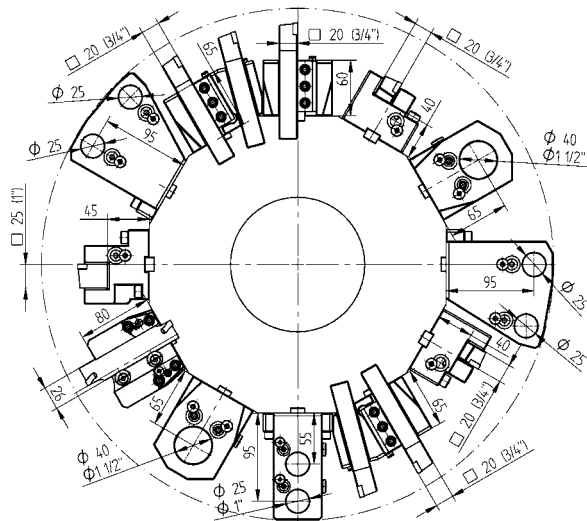

Static Toolholders - Standard Program

Static Toolholders - Standard Program

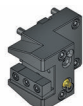

OD cutting holder

- 20** 48-95083
- 3/4"** 48-95084

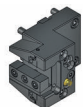

OD cutting holder, HP-IC

- 20** 48-100605-HP IC 80 bar
- 25** 48-104395-HP IC 80 bar
- 3/4"** 48-108926-HP IC 80 bar
- 1"** 48-104396-HP IC 80 bar

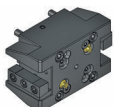

OD cutting holder, both sides

- 20** 48-95085
- 3/4"** 48-95086

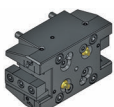

OD cutting holder, both sides, HP-IC

- 20** 48-95085-HP IC 80 bar
- 3/4"** 48-95086-HP IC 80 bar



Face cutting holder

- 20** 48-109148



Face cutting holder

- 3/4"** 48-95338



Face cutting holder, HP-IC

- 20** 48-109148-HP IC 80 bar
- 25** 48-104397-HP IC 80 bar
- 3/4"** 48-109149-HP IC 80 bar
- 1"** 48-104398-HP IC 80 bar





Combination toolholder, LF=65

- Ø 40** 48-95090 IC 80 bar
- Ø 1 1/2"** 48-95327 IC 80 bar



Combination toolholder, universal, LF=85

- Ø 32** 48-95998 IC 80 bar
-  241132016 ER25
-  241132020 ER32
- Ø 1 1/4"** 48-96029 IC 80 bar
-  2411125020 ER32



Boring bar holder universal, double

- Ø 25** 48-95093
- Ø 1"** 48-95325

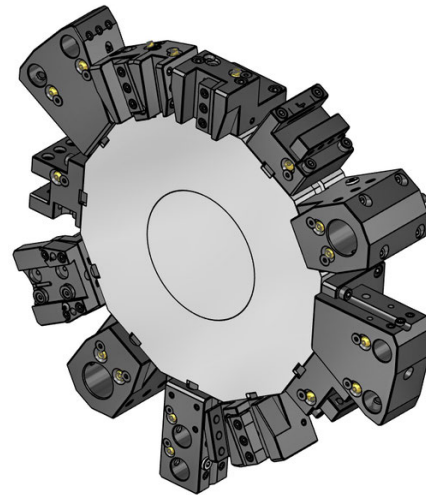
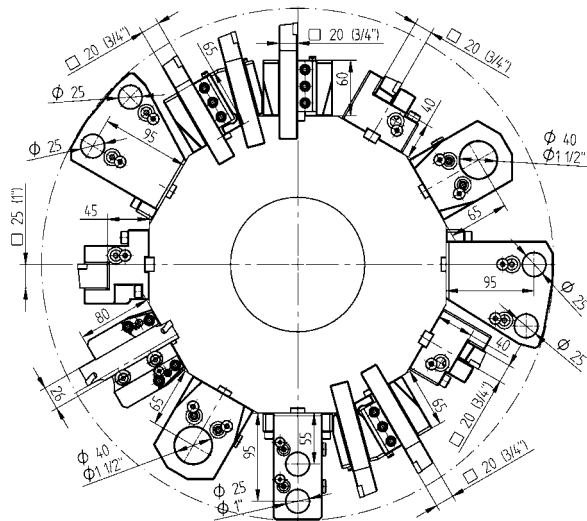

Static Toolholders - Enhanced Program



OD cutting holder, double, 24 station
 20 48-95088



OD cutting holder, both sides, double, 24 station
 20 48-95355

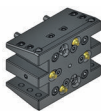

OD cutting holder, both sides, double, Y axis
 20 (3/4") 48-110811



Cut-off holder, adjustable
 SH 26 48-94968



Cut-off holder, adjustable, HP-IC
 SH 26 48-102252R IC 80 bar
 SH 26 48-102252L IC 80 bar



Boring bar holder, universal, double, 24 station
 Ø 25 48-95092

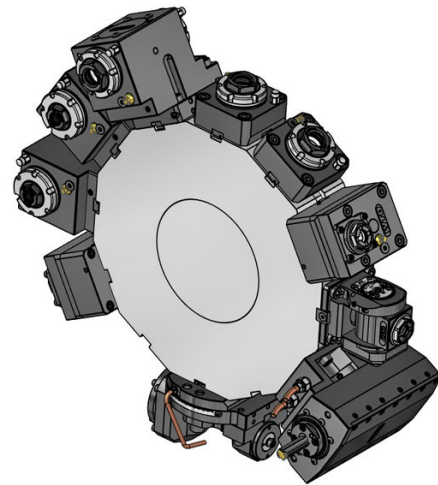
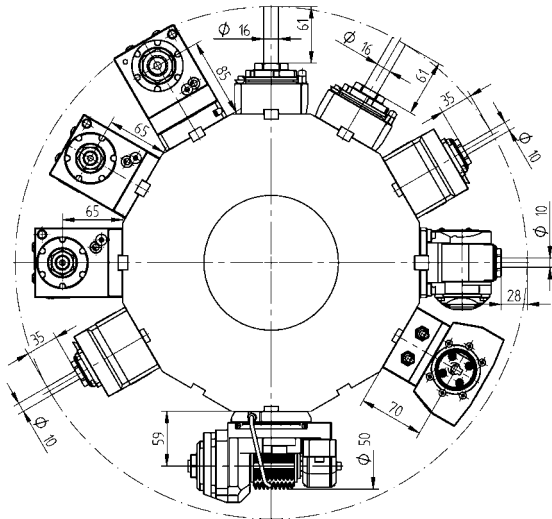

Driven Toolholders - QuickFlex®



Straight drill/milling unit

ER-25 QF 420125015-45 1:1 EC
 0067725000

ER-25 QF 420125016-45 1:1 IC 80 bar
 0067725000



Straight drill/milling unit (12000 RPM)

ER-25 QF 420125019-45 1:1 EC
 0067725000

ER-25 QF 420125020-45 1:1 IC 80 bar
 0067725000



Right angle drill/milling unit

ER-25 QF 420525015-45 1:1 EC
 0067725000

ER-25 QF 420525016-45 1:1 IC 80 bar
 0067725000



Right angle drill/milling unit (12000 RPM)

ER-25 QF 420525038-45 1:1 EC
 0067725000

ER-25 QF 420525039-45 1:1 IC 80 bar
 0067725000



Right angle back set drill/milling unit, LF=85

ER-25 QF 420525024-45 1:1 EC
 0067725000

ER-25 QF 420525025-45 1:1 IC 80 bar
 0067725000



Right angle back set drill/milling unit, LF=85, (12000 RPM)

ER-25 QF 420525049-45 1:1 EC
 0067725000

ER-25 QF 420525050-45 1:1 IC 80 bar
 0067725000

Driven Toolholders - QuickFlex®



Right angle drill/milling unit, both sides, LF=85

ER-25 QF 420525043-45 1:1 EC
 0067725000



Right angle drill/milling unit, both sides, LF=85, (12000 RPM)

ER-25 QF 420525051-45 1:1 EC
 0067725000

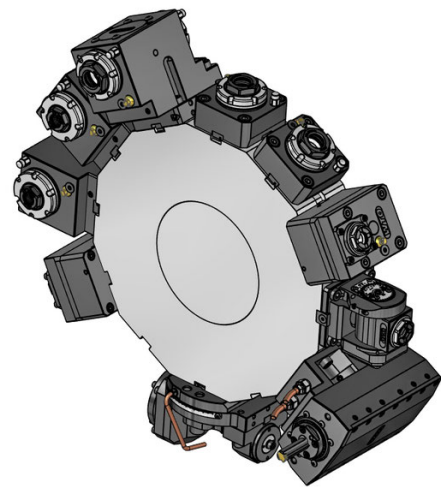
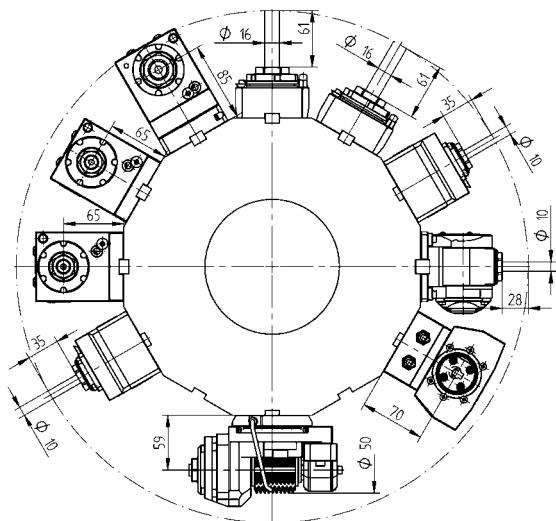

Driven Toolholders - Enhanced Program



- Straight offset drill/milling unit**
- | | | | |
|--------------|--------------|-----|-----------|
| ER 16 | 410410008-45 | 1:3 | EC |
| | 00675000937 | | |
| ER 16 | 410410002-45 | 1:3 | IC 80 bar |
| | 00675000937 | | |



- Right angle drill/milling unit**
- | | | | |
|-----------------|--------------|-----|-----------|
| ER-20 QF | 420520018-45 | 1:2 | EC |
| | 0067720001 | | |
| ER-20 QF | 420520019-45 | 1:2 | IC 80 bar |
| | 0067720001 | | |
| ER-25 QF | 420525020-45 | 2:1 | EC |
| | 0067725000 | | |
| ER-25 QF | 420525021-45 | 2:1 | IC 80 bar |
| | 0067725000 | | |

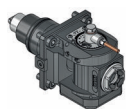

- Adjustable angle drill/milling unit**
- | | | | |
|--------------|--------------|-----|-----------|
| ER 16 | 411010002-45 | 1:1 | EC |
| | 00675000902 | | |
| ER 16 | 411010003-45 | 1:1 | IC 80 bar |
| | 00675000902 | | |
| ER 11 | 411007004-45 | 1:2 | EC |
| | 00675000914 | | |
| ER 11 | 411007005-45 | 1:2 | IC 80 bar |
| | 00675000914 | | |

Driven Toolholders - Enhanced Program



- Gear hobbing unit**
- | | | | |
|------------------|------------------|-----|----|
| Type 15-2 | 410900001-45 | 1:1 | EC |
| | 00675001015 | | |
| | 160008152 Ø 8 | | |
| | 160010152 Ø 10 | | |
| | 160013152 Ø 13 | | |
| | 160016152 Ø 16 | | |
| | 160022152 Ø 22 | | |
| | 160015152 Ø 5/8" | | |
| | 160019152 Ø 3/4" | | |
| | 110587 | | |



- Straight drill/milling unit, double, Y axis**
- | | | | |
|--------------|--------------|-----|-----------|
| ER 20 | 413002006-45 | 1:1 | EC |
| | 00675000947 | | |
| ER 20 | 413002008-45 | 1:1 | IC 80 bar |
| | 00675000947 | | |

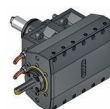

- Broaching unit for ID and OD**
- | | | | |
|-----------------|--------------|-----|----|
| TN765050 | 414532000-45 | 1:1 | EC |
|-----------------|--------------|-----|----|

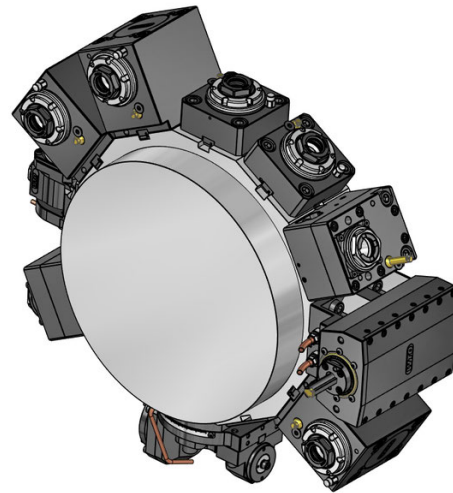
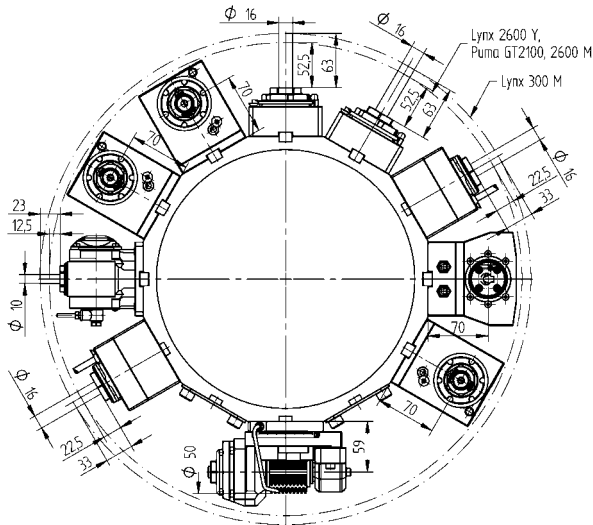

Driven Toolholders - QuickFlex®



Straight drill/milling unit

ER-25 QF 420125015-55 1:1 EC
 0067725000

ER-25 QF 420125016-55 1:1 IC 80 bar
 0067725000



Right angle drill/milling unit, LF=70

ER-25 QF 420525015-55 1:1 EC
 0067725000

ER-25 QF 420525016-55 1:1 IC 80 bar
 0067725000

Driven Toolholders - Enhanced Program



Straight drill/milling unit

ER 32 410120010-55 1:1 EC
 0067725000

ER 32 410120011-55 1:1 IC 80 bar
 0067725000

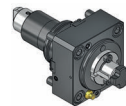

Straight milling unit with combination mill arbor DIN 6358

Ø 22 410222004-55 1:1 EC
 00675000483

Ø 3/4" 410219002-55 1:1 EC
 00675000483



Straight offset drill/milling unit

ER 25 410116029-55 1:1 EC
 00675000932

ER 25 410116030-55 1:1 IC 80 bar
 00675000932

ER 20 410113009-55 1:2 EC
 00675000939

ER 20 410113010-55 1:2 IC 80 bar
 00675000939

ER 16 410410004-55 1:3 EC
 00675000937

ER 16 410410005-55 1:3 IC 80 bar
 00675000937

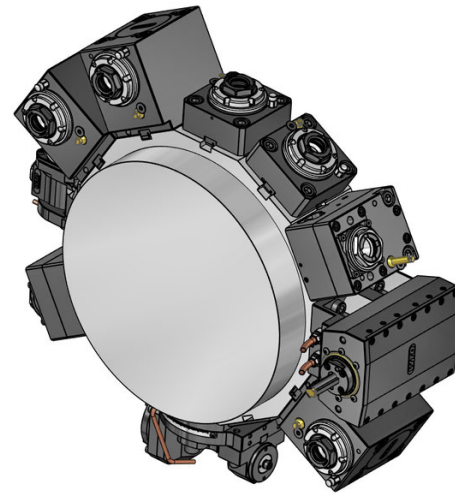
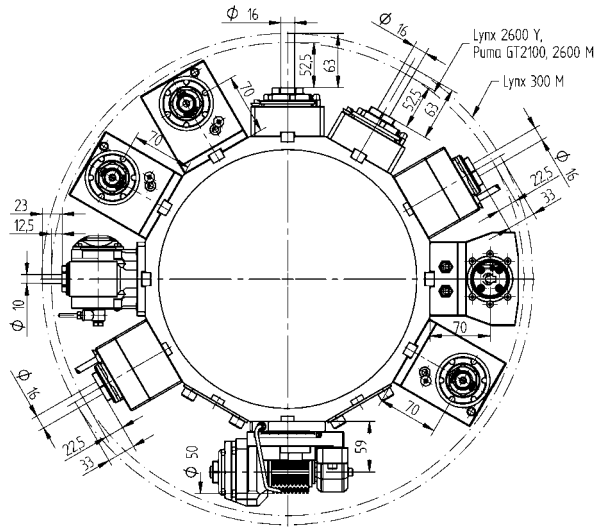

Driven Toolholders - Enhanced Program



Right angle drill/milling unit, LF=70

ER 32	410520033-55	1:1	EC
	0067725000		
ER 32	410520034-55	1:1	IC 80 bar
	0067725000		
ER-20 QF	420520012-55	1:2	EC
	0067720001		
ER-20 QF	420520013-55	1:2	IC 80 bar
	0067720001		
ER 16	410810016-55	1:3	EC
	00675000841		
ER 16	410810017-55	1:3	IC 80 bar
	00675000841		
ER-25 QF	420525030-55	2:1	EC
	0067725000		
ER-25 QF	420525031-55	2:1	IC 80 bar
	0067725000		



Right angle milling unit with combination mill arbor DIN 6358, LF=70

Ø 22	410622010-55	1:1	EC
	00675000483		
Ø 3/4"	410619005-55	1:1	EC
	00675000483		

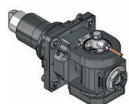

Adjustable angle drill/milling unit

ER 16	411010005-55	1:1	EC
	00675000902		
ER 16	411010006-55	1:1	IC 80 bar
	00675000902		
ER 11	411007007-55	1:2	EC
	00675000914		
ER 11	411007008-55	1:2	IC 80 bar
	00675000914		

Driven Toolholders - Enhanced Program



Gear hobbing unit

Type 15-2	410900002-55	1:1	EC
	00675001015		
	160008152 Ø 8		
	160010152 Ø 10		
	160013152 Ø 13		
	160016152 Ø 16		
	160022152 Ø 22		
	160015152 Ø 5/8"		
	160019152 Ø 3/4"		
	110587		

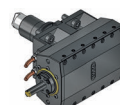

Broaching unit for ID and OD

TN765050	414532001-55	1:1	EC
-----------------	--------------	-----	----

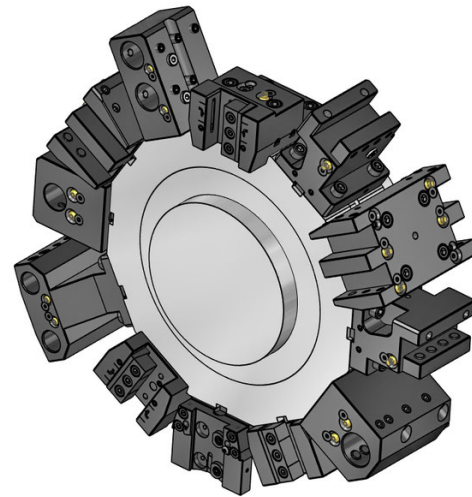
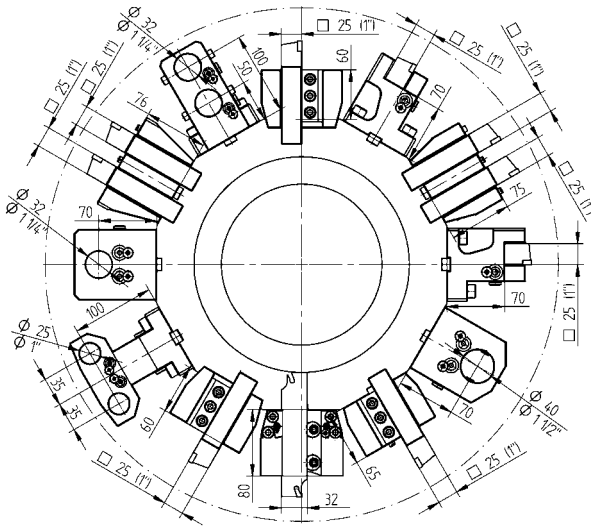

Static Toolholders - Standard Program

Static Toolholders - Enhanced Program



OD cutting holder

25 48-87097
1" 48-87098



OD cutting holder, HP-IC

25 48-87097-HP IC 80 bar
1" 48-87098-HP IC 80 bar



OD cutting holder, both sides

25 48-87099
1" 48-87100



OD cutting holder, both sides, HP-IC

25 48-87099-HP IC 80 bar
1" 48-87100-HP IC 80 bar

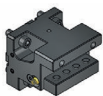

Face cutting holder

25 48-87101
1" 48-87102

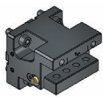

Face cutting holder, HP-IC

25 48-87101-HP IC 80 bar
1" 48-87102-HP IC 80 bar



Combination toolholder, LF=70

Ø 32 48-106897 IC 80 bar
Ø 40 48-87103 IC 80 bar
Ø 1 1/4" 48-106872 IC 80 bar
Ø 1 1/2" 48-87104 IC 80 bar

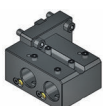

Boring bar holder, double

Ø 32 48-87149
Ø 1 1/4" 48-87150



Cover plate

48-87111



OD cutting holder, double, Y axis

25(1") 48-87140

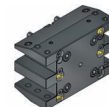

OD cutting holder, both sides, double, Y axis

25(1") 48-87141



Cut-off holder, adjustable

SH 32 48-103287



Cut-off holder, adjustable, HP-IC

SH 32 48-110160R IC 80 bar
SH 32 48-110160L IC 80 bar



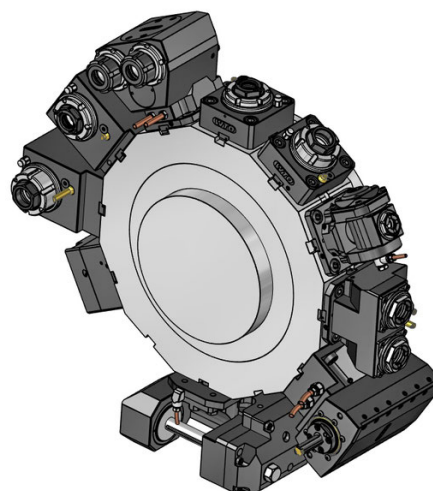
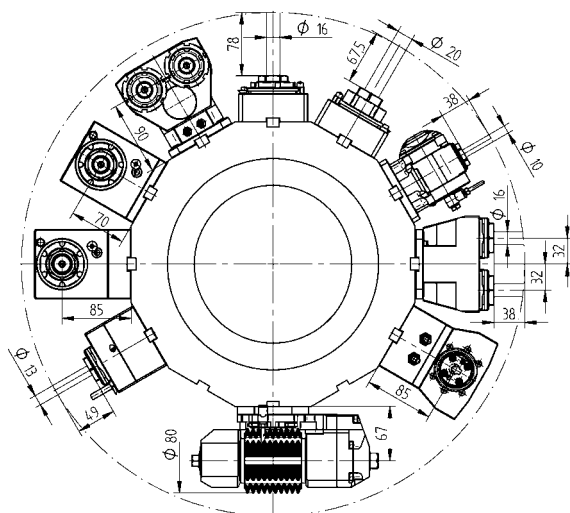

Boring bar holder, both sides, double, Y axis

Ø 25 48-87147
Ø 1" 48-87148



Driven Toolholders - QuickFlex®

- 

Straight drill/milling unit
ER-25 QF 420125015-55 1:1 EC
 0067725000
ER-25 QF 420125016-55 1:1 IC 80 bar
 0067725000
- 

Right angle drill/milling unit, LF=70
ER-25 QF 420525015-55 1:1 EC
 0067725000
ER-25 QF 420525016-55 1:1 IC 80 bar
 0067725000
- 

Right angle drill/milling unit, LF=85
ER-25 QF 420525018-55 1:1 EC
 0067725000
ER-25 QF 420525019-55 1:1 IC 80 bar
 0067725000
- 

Right angle drill/milling unit, both sides, LF=85
ER-25 QF 420525020-55 1:1 EC
 0067725000

Driven Toolholders - Enhanced Program

- 

Straight drill/milling unit
ER 32 410120010-55 1:1 EC
 0067725000
ER 32 410120011-55 1:1 IC 80 bar
 0067725000
- 

Straight milling unit with combination mill arbor DIN 6358
Ø 22 410222004-55 1:1 EC
 00675000483
Ø 3/4" 410219002-55 1:1 EC
 00675000483
- 

Straight offset drill/milling unit
ER 25 410116029-55 1:1 EC
 00675000932
ER 25 410116030-55 1:1 IC 80 bar
 00675000932
ER 20 410113009-55 1:2 EC
 00675000939
ER 20 410113010-55 1:2 IC 80 bar
 00675000939
ER 16 410410004-55 1:3 EC
 00675000937
ER 16 410410005-55 1:3 IC 80 bar
 00675000937

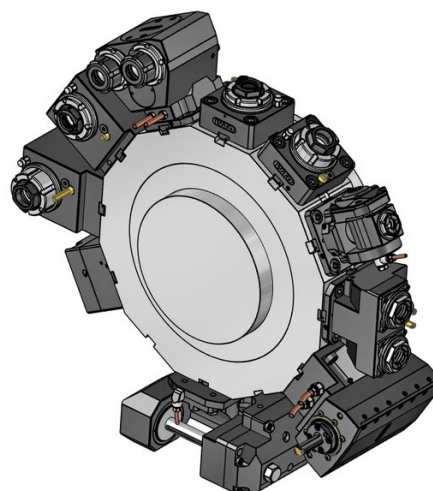
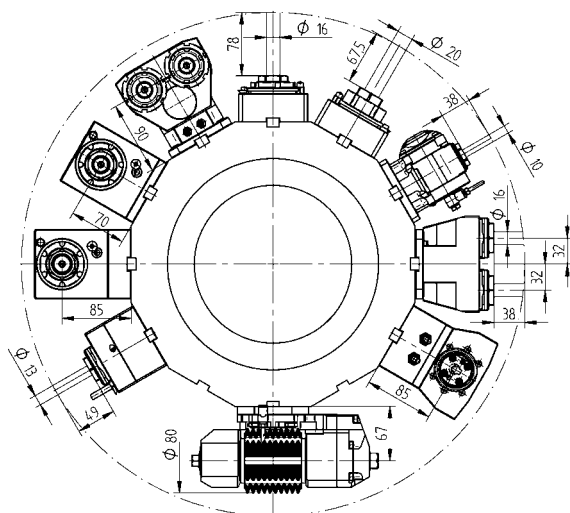

Driven Toolholders - Enhanced Program



Right angle drill/milling unit, LF=70

ER 32	410520033-55	1:1	EC
	0067725000		
ER 32	410520034-55	1:1	IC 80 bar
	0067725000		
ER-20 QF	420520012-55	1:2	EC
	0067720001		
ER-20 QF	420520013-55	1:2	IC 80 bar
	0067720001		
ER 16	410810016-55	1:3	EC
	00675000841		
ER 16	410810017-55	1:3	IC 80 bar
	00675000841		
ER-25 QF	420525030-55	2:1	EC
	0067725000		
ER-25 QF	420525031-55	2:1	IC 80 bar
	0067725000		



Right angle drill/milling unit, LF=85

ER 32	410520030-55	1:1	EC
	0067725000		
ER 32	410520031-55	1:1	IC 80 bar
	0067725000		
ER-20 QF	420520014-55	1:2	EC
	0067720001		
ER-20 QF	420520015-55	1:2	IC 80 bar
	0067720001		
ER 16	410810020-55	1:3	EC
	00675000841		
ER 16	410810021-55	1:3	IC 80 bar
	00675000841		
ER-25 QF	420525032-55	2:1	EC
	0067725000		
ER-25 QF	420525033-55	2:1	IC 80 bar
	0067725000		

Driven Toolholders - Enhanced Program



Right angle milling unit with combination mill arbor DIN 6358, LF=70

Ø 22	410622010-55	1:1	EC
	00675000483		
Ø 3/4"	410619005-55	1:1	EC
	00675000483		



Right angle milling unit with combination mill arbor DIN 6358, LF=85

Ø 22	410622011-55	1:1	EC
	00675000483		
Ø 3/4"	410619006-55	1:1	EC
	00675000483		

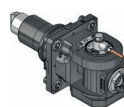

Adjustable angle drill/milling unit

ER 16	411010005-55	1:1	EC
	00675000902		
ER 16	411010006-55	1:1	IC 80 bar
	00675000902		
ER 11	411007007-55	1:2	EC
	00675000914		
ER 11	411007008-55	1:2	IC 80 bar
	00675000914		

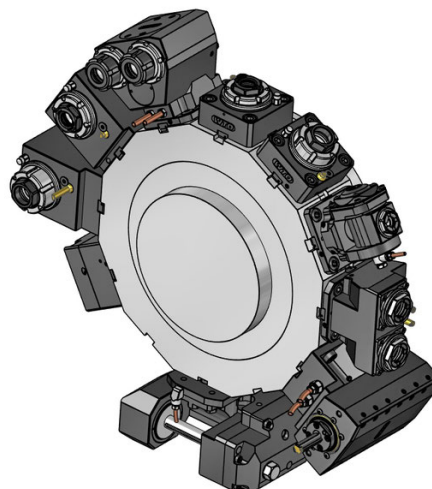
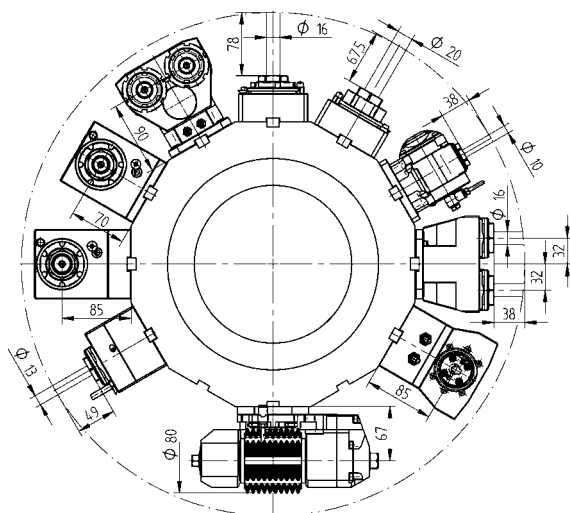

Driven Toolholders - Enhanced Program



Gear hobbing unit

Type 16-1	411500002-55	1:1	EC
Type 16-1	411500001-55	2:1	EC

- 00675000927
- 160016161 Ø 16
- 160022161 Ø 22
- 160027161 Ø 27
- 160015161 Ø 5/8"
- 160019161 Ø 3/4"
- 160025161 Ø 1"
- 160031161 Ø 1 1/4"
- 110587



Straight drill/milling unit, double, Y axis

ER 25	413002004-55	1:1	EC
	00675000970		
ER 25	413002003-55	1:1	IC 80 bar
	00675000970		



2-spindle - Right angle drill/milling unit, Y axis

ER 25	413502007-55	1:1	EC
	00675000915		
ER 25	413502008-55	1:1	IC 80 bar
	00675000915		

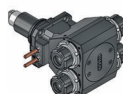

2-spindle - Right angle drill/milling unit, both sides, Y axis

ER 25	413502006-55	1:1	EC
	00675000915		



Broaching unit for ID and OD

TN765050	414532000-55	1:1	EC
-----------------	--------------	-----	----

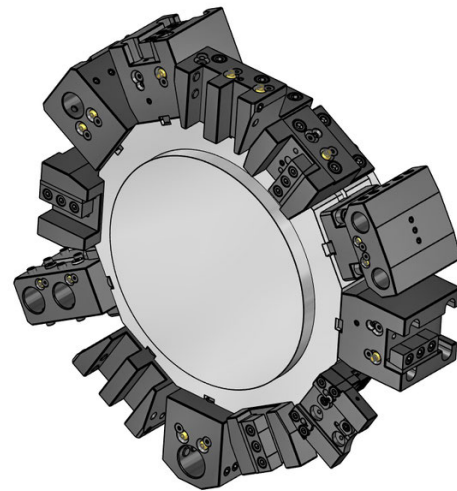
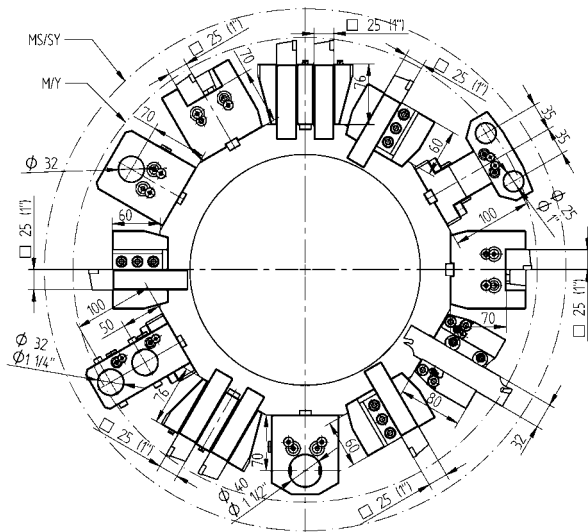

Static Toolholders - Standard Program (12ST)

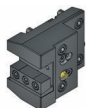

OD cutting holder

25 48-87097
1" 48-87098

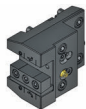

OD cutting holder, HP-IC

25 48-87097-HP IC 80 bar
1" 48-87098-HP IC 80 bar



OD cutting holder, both sides

25 48-87099
1" 48-87100



OD cutting holder, both sides, HP-IC

25 48-87099-HP IC 80 bar
1" 48-87100-HP IC 80 bar

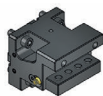

Face cutting holder

25 48-87101
1" 48-87102



Face cutting holder, HP-IC

25 48-87101-HP IC 80 bar
1" 48-87102-HP IC 80 bar



Combination toolholder, LF=70

Ø 32 48-106897 IC 80 bar
Ø 40 48-87103 IC 80 bar
Ø 1 1/4" 48-106872 IC 80 bar
Ø 1 1/2" 48-87104 IC 80 bar

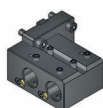

Boring bar holder, double

Ø 32 48-87149
Ø 1 1/4" 48-87150



Cover plate

48-87111

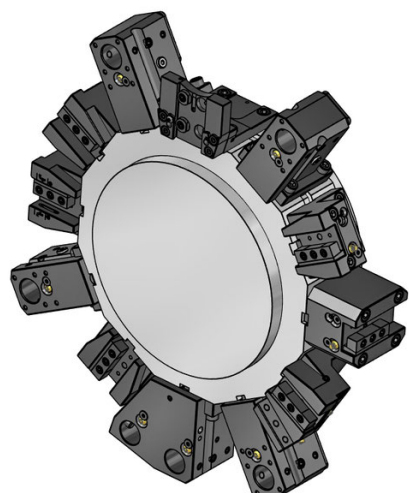
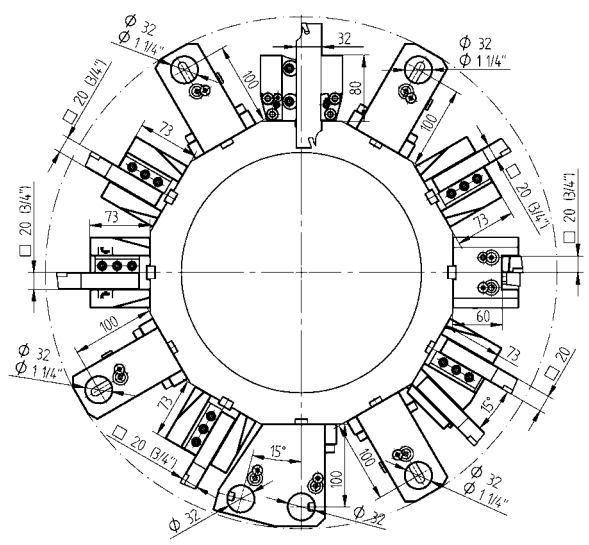

Static Toolholders - Standard Program (24ST)

Static Toolholders - Standard Program (24ST)

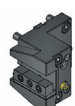

OD cutting holder
 20 48-92036
 3/4" 48-92037



OD cutting holder, HP-IC
 20 48-92036-HP IC 80 bar
 3/4" 48-92037-HP IC 80 bar

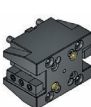

OD cutting holder, both sides
 20 48-92038
 3/4" 48-92039

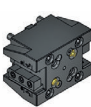

OD cutting holder, both sides, HP-IC
 20 48-92038-HP IC 80 bar
 3/4" 48-92039-HP IC 80 bar



Face cutting holder
 20 48-92045
 3/4" 48-92046

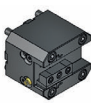

Face cutting holder, HP-IC
 20 48-92045-HP IC 80 bar
 3/4" 48-92046-HP IC 80 bar



Combination toolholder, universal, LF=100
 Ø 32 48-92043 IC 80 bar
 241132016 ER25
 241132020 ER32
 Ø 1 1/4" 48-92044 IC 80 bar
 2411125020 ER32



Boring bar holder, double
 Ø 32 48-87149
 Ø 1 1/4" 48-87150



Cover plate
 48-87111

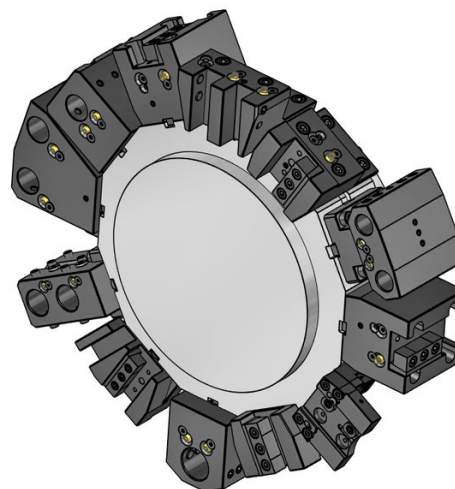
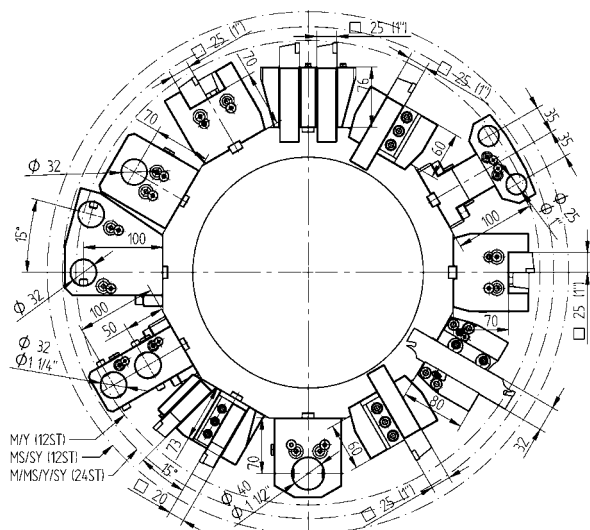

Static Toolholders - Enhanced Program



OD cutting holder, double, 24 station
 20 48-92069 EC

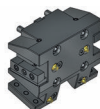

OD cutting holder, both sides, double, 24 station
 20 48-92071



OD cutting holder, double, Y axis
 25(1") 48-87140



OD cutting holder, both sides, double, Y axis
 25(1") 48-87141



Cut-off holder, adjustable
 SH 32 48-103287



Cut-off holder, adjustable, HP-IC
 SH 32 48-110160R IC 80 bar
 SH 32 48-110160L IC 80 bar



Boring bar holder, both sides, double, Y axis
 Ø 25 48-87147
 Ø 1" 48-87148



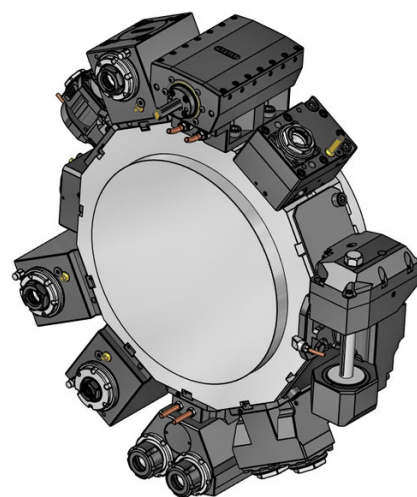
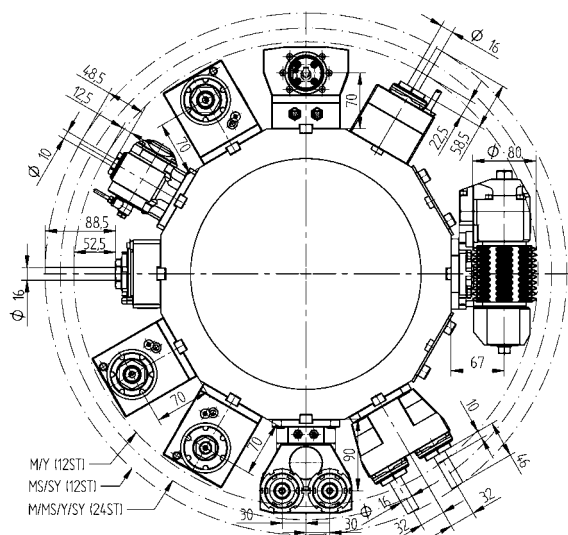

Boring bar holder, double, 24 station
 Ø 32 48-92073



Driven Toolholders - QuickFlex®

- 

Straight drill/milling unit
ER-25 QF 420125015-55 1:1 EC
 0067725000
ER-25 QF 420125016-55 1:1 IC 80 bar
 0067725000
- 

Right angle drill/milling unit, LF=70
ER-25 QF 420525015-55 1:1 EC
 0067725000
ER-25 QF 420525016-55 1:1 IC 80 bar
 0067725000
- 

Right angle drill/milling unit, both sides, LF=70
ER-25 QF 420525017-55 1:1 EC
 0067725000

Driven Toolholders - Enhanced Program

- 

Straight drill/milling unit
ER 32 410120010-55 1:1 EC
 0067725000
ER 32 410120011-55 1:1 IC 80 bar
 0067725000
- 

Straight milling unit with combination mill arbor DIN 6358
Ø 22 410222004-55 1:1 EC
 00675000483
Ø 3/4" 410219002-55 1:1 EC
 00675000483
- 

Straight offset drill/milling unit
ER 25 410116029-55 1:1 EC
 00675000932
ER 25 410116030-55 1:1 IC 80 bar
 00675000932
ER 20 410113009-55 1:2 EC
 00675000939
ER 20 410113010-55 1:2 IC 80 bar
 00675000939
ER 16 410410004-55 1:3 EC
 00675000937
ER 16 410410005-55 1:3 IC 80 bar
 00675000937

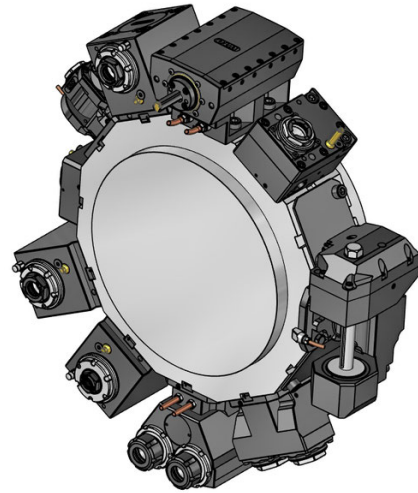
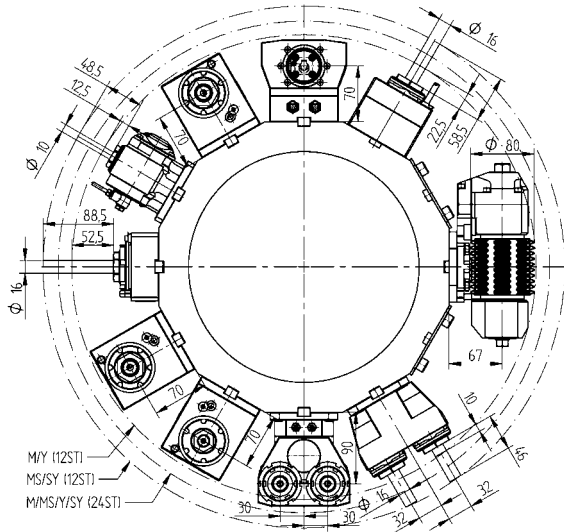

Driven Toolholders - Enhanced Program



Right angle drill/milling unit, LF=70

ER 32	410520033-55	1:1	EC
	0067725000		
ER 32	410520034-55	1:1	IC 80 bar
	0067725000		
ER-20 QF	420520012-55	1:2	EC
	0067720001		
ER-20 QF	420520013-55	1:2	IC 80 bar
	0067720001		
ER 16	410810016-55	1:3	EC
	00675000841		
ER 16	410810017-55	1:3	IC 80 bar
	00675000841		
ER-25 QF	420525030-55	2:1	EC
	0067725000		
ER-25 QF	420525031-55	2:1	IC 80 bar
	0067725000		



Right angle milling unit with combination mill arbor DIN 6358, LF=70

$\phi 22$	410622010-55	1:1	EC
	00675000483		
$\phi 3/4"$	410619005-55	1:1	EC
	00675000483		



Right angle back set drill/milling unit

ER 25	410516024-55	1:1	EC
	00675000801		
ER 25	410516025-55	1:1	IC 80 bar
	00675000801		

Driven Toolholders - Enhanced Program



Adjustable angle drill/milling unit

ER 16	411010005-55	1:1	EC
	00675000902		
ER 16	411010006-55	1:1	IC 80 bar
	00675000902		
ER 11	411007007-55	1:2	EC
	00675000914		
ER 11	411007008-55	1:2	IC 80 bar
	00675000914		

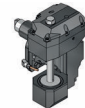

Gear hobbing unit

Type 16-1	411500002-55	1:1	EC
Type 16-1	411500001-55	2:1	EC
	00675000927		
	160016161 $\phi 16$		
	160022161 $\phi 22$		
	160027161 $\phi 27$		
	160015161 $\phi 5/8"$		
	160019161 $\phi 3/4"$		
	160025161 $\phi 1"$		
	160031161 $\phi 1 1/4"$		
	110587		

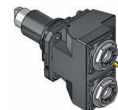

Straight drill/milling unit, double, Y axis

ER 25	413002004-55	1:1	EC
	00675000970		
ER 25	413002003-55	1:1	IC 80 bar
	00675000970		



2-spindle - Right angle drill/milling unit, Y axis

ER 25	413502007-55	1:1	EC
	00675000915		
ER 25	413502008-55	1:1	IC 80 bar
	00675000915		

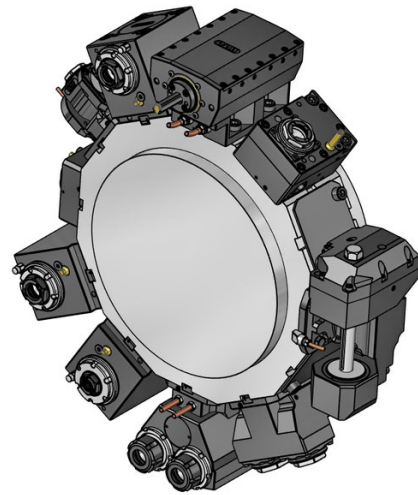
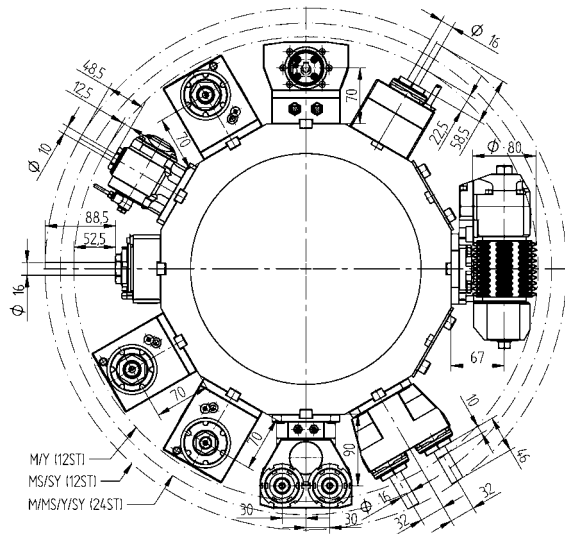

Driven Toolholders - Enhanced Program

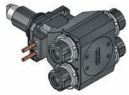

2-spindle - Right angle drill/milling unit, both sides, Y axis

ER 25 413502006-55 1:1 EC
 00675000915



Broaching unit for ID and OD

TN765050 414532001-55 1:1 EC

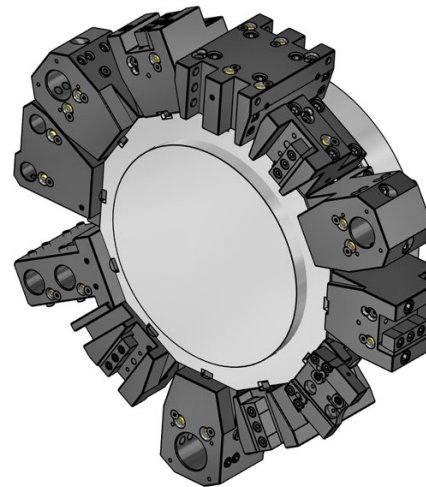
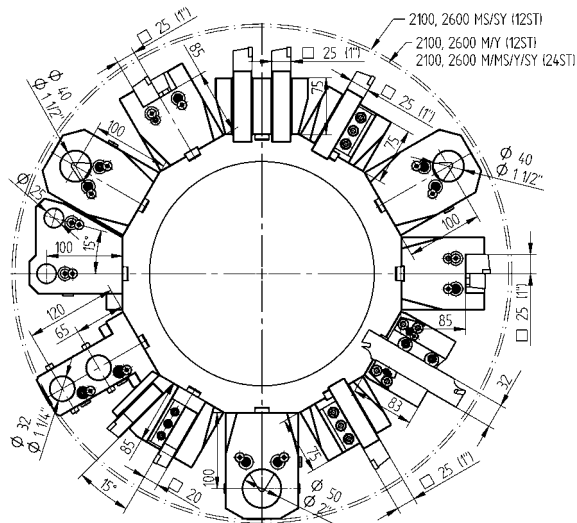

Static Toolholders - Standard Program

Static Toolholders - Standard Program



OD cutting holder

25 48-92428
1" 48-92466



OD cutting holder, HP-IC

25 48-92428-HP IC 80 bar
1" 48-92466-HP IC 80 bar

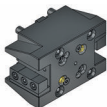

OD cutting holder, both sides

25 48-92438
1" 48-92472



OD cutting holder, both sides, HP-IC

25 48-92438-HP IC 80 bar
1" 48-92472-HP IC 80 bar



Face cutting holder, long

25 48-92958
1" 48-92959



Combination toolholder, LF=100

Ø 40 48-92397 IC 80 bar
 241140020 ER32
 241140026 ER40
Ø 50 48-92467 IC 80 bar
Ø 1 1/2" 48-92468 IC 80 bar
 2411150020 ER32
Ø 2" 48-92469 IC 80 bar



Boring bar holder, both sides

Ø 32 48-101033
Ø 1 1/4" 48-113514



Boring bar holder, double

Ø 32 48-84524
Ø 1 1/4" 48-86905



Cover plate

48-87089

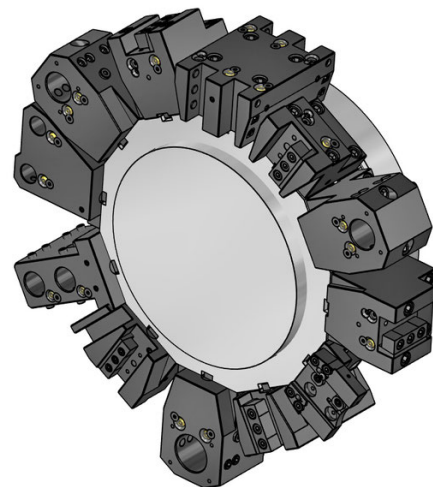
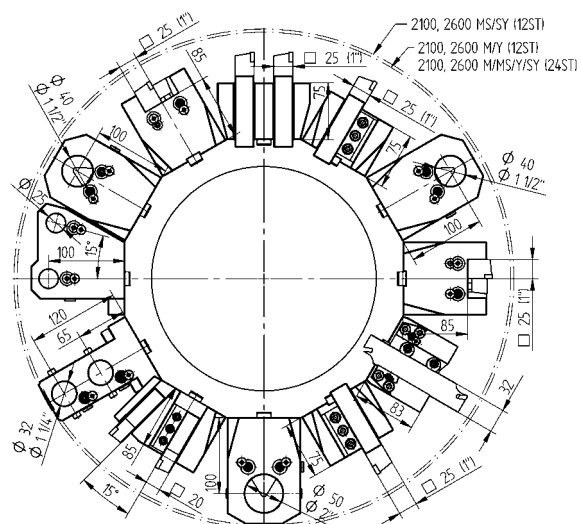

Static Toolholders - Enhanced Program

Static Toolholders - Enhanced Program



OD cutting holder, short

25 48-86991
 1" 48-86992

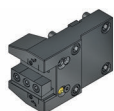

OD cutting holder, short, HP-IC

25 48-86991-HP IC 80 bar
 1" 48-86992-HP IC 80 bar

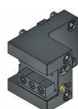

OD cutting holder, long

25 48-86711
 1" 48-86712

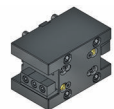

OD cutting holder, both sides, long

25 48-84523
 1" 48-86718



OD cutting holder, double, 24 station

20 48-92089



OD cutting holder, both sides, double, 24 station

20 48-92091



OD cutting holder, double, Y axis

25(1") 48-86103



OD cutting holder, both sides, double, Y axis

25(1") 48-86150



Cut-off holder, adjustable

SH 32 48-99060



Cut-off holder, adjustable, HP-IC

SH 32 48-102256R IC 80 bar
 SH 32 48-102256L IC 80 bar



Cut-off holder, adjustable, long, HP-IC

SH 32 48-100082R IC 80 bar
 SH 32 48-100082L IC 80 bar



Boring bar holder, double, 24 station

Ø 25 48-92102



Combination toolholder, both sides, double, 24 station

Ø 25 48-109092
 Ø 1" 48-108887



Boring bar holder, double, both sides

Ø 32 48-86160
 Ø 1 1/4" 48-86274

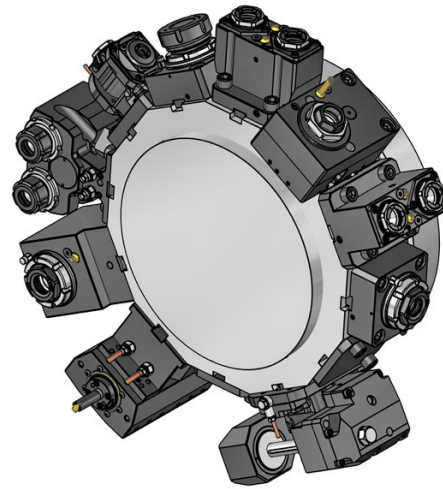
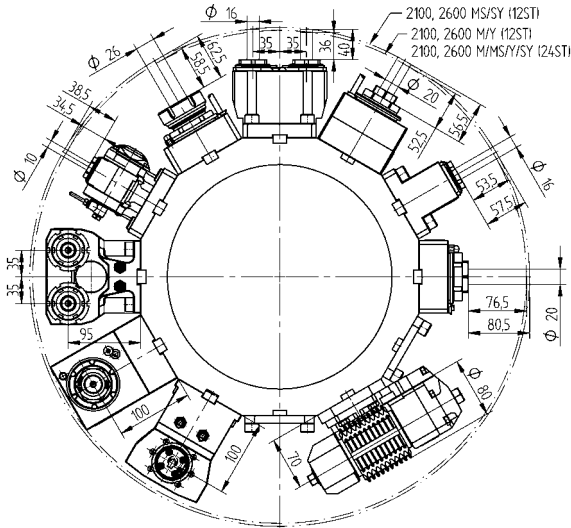

Driven Toolholders - QuickFlex®

- 

Straight drill/milling unit
ER-32 QF 420132015-65 1:1 EC
 0067732000

ER-32 QF 420132016-65 1:1 IC 80 bar
 0067732000
- 

Right angle drill/milling unit, LF=100
ER-32 QF 420532018-65 1:1 EC
 0067732000

ER-32 QF 420532019-65 1:1 IC 80 bar
 0067732000
- 

Right angle drill/milling unit, both sides, LF=100
ER-32 QF 420532020-65 1:1 EC
 0067732000

Driven Toolholders - Enhanced Program

- 

Straight drill/milling unit
ER 40 410126001-65 1:1 EC
 00675000079
- 

Straight milling unit with combination mill arbor DIN 6358
Ø 22 410222002-65 1:1 EC
 00675000483

Ø 1" 410225002-65 1:1 EC
 00675000483
- 

Straight offset drill/milling unit
ER-32 QF 420132037-65 1:1 EC
 0067732000

ER-32 QF 420132038-65 1:1 IC 80 bar
 0067732000

ER-25 QF 420125010-65 1:2 EC
 0067725001

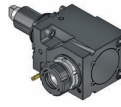
ER-25 QF 420125011-65 1:2 IC 80 bar
 0067725001
- 

Right angle drill/milling unit, LF=100
ER 40 410526007-65 1:1 EC
 00675000079

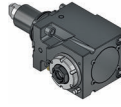
ER 40 410526008-65 1:1 IC 80 bar
 00675000079
- 

Right angle drill/milling unit, LF=100
ER-25 QF 420525012-65 1:2 EC
 0067725001

ER-25 QF 420525013-65 1:2 IC 80 bar
 0067725001

ER-32 QF 420532029-65 2:1 EC
 0067732000

ER-32 QF 420532030-65 2:1 IC 80 bar
 0067732000

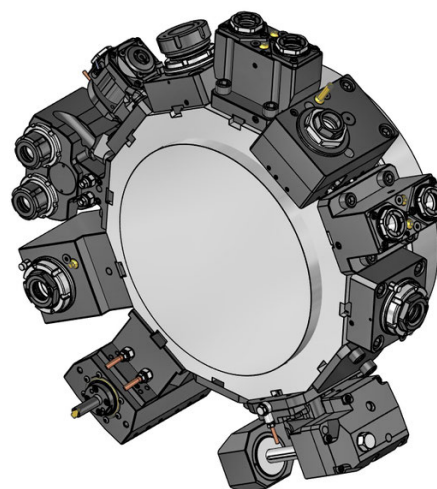
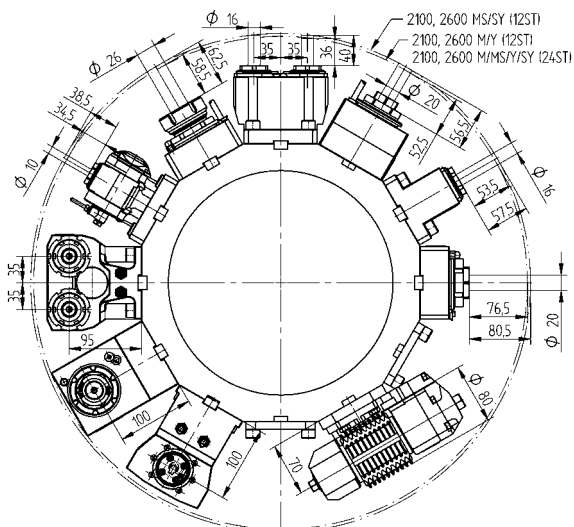

Driven Toolholders - Enhanced Program

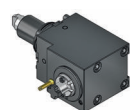

Right angle milling unit with combination mill arbor DIN 6358, LF=100

- Ø 22** 410622002-65 1:1 EC
 00675000483
- Ø 1"** 410625002-65 1:1 EC
 00675000483



Adjustable angle drill/milling unit

- ER 16** 411010002-65 1:1 EC
 00675000902
- ER 16** 411010003-65 1:1 IC 80 bar
 00675000902
- ER 11** 411007002-65 1:2 EC
 00675000914
- ER 11** 411007003-65 1:2 IC 80 bar
 00675000914



Gear hobbing unit

- Type 16-1** 411500003-65 1:1 EC
- Type 16-1** 411500002-65 2:1 EC
 00675000927
- 160016161 Ø 16
- 160022161 Ø 22
- 160027161 Ø 27
- 160015161 Ø 5/8"
- 160019161 Ø 3/4"
- 160025161 Ø 1"
- 160031161 Ø 1 1/4"
- 110587



Straight drill/milling unit, both sides

- ER 25** 413002001-65 1:1 EC
 00675000907

Driven Toolholders - Enhanced Program



Straight drill/milling unit, double, Y axis

- ER 25** 413002004-65 1:1 EC
 00675000907

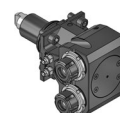

2-spindle - Right angle drill/milling unit, Y axis

- ER 25** 413502006-65 1:1 EC
 00675000915
- ER 25** 413502007-65 1:1 IC 80 bar
 00675000915

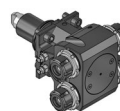

2-spindle - Right angle drill/milling unit, both sides, Y axis

- ER 25** 413502008-65 1:1 EC
 00675000915

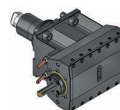

Broaching unit for ID and OD

- TN765050** 414532000-65 1:1 EC

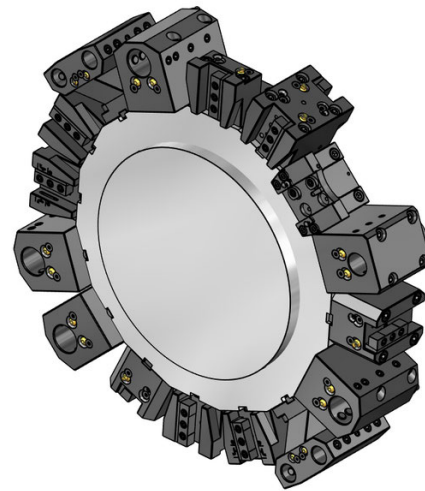
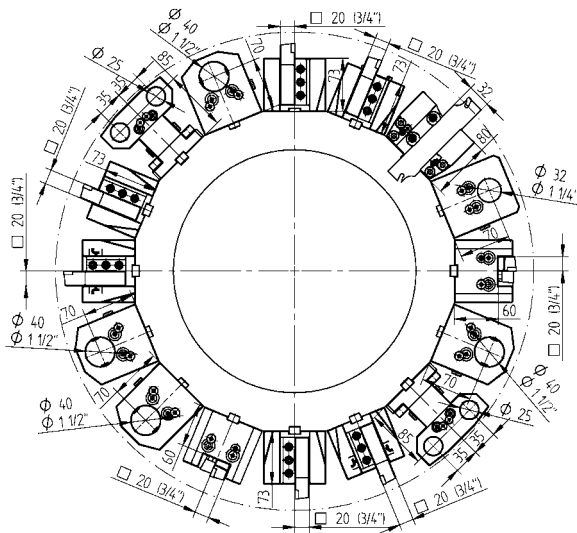

Static Toolholders - Standard Program

Static Toolholders - Enhanced Program

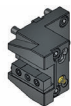

OD cutting holder

20 48-92036
3/4" 48-92037



OD cutting holder, HP-IC

20 48-92036-HP IC 80 bar
3/4" 48-92037-HP IC 80 bar



OD cutting holder, both sides

20 48-92038
3/4" 48-92039



OD cutting holder, both sides, HP-IC

20 48-92038-HP IC 80 bar
3/4" 48-92039-HP IC 80 bar



Face cutting holder

20 48-92045
3/4" 48-92046



Face cutting holder, HP-IC

20 48-92045-HP IC 80 bar
3/4" 48-92046-HP IC 80 bar



Combination toolholder, LF=70

Ø 32 48-106897 IC 80 bar
Ø 40 48-87103 IC 80 bar
Ø 1 1/4" 48-106872 IC 80 bar
Ø 1 1/2" 48-87104 IC 80 bar



Cover plate

48-87111



Cut-off holder, adjustable

SH 32 48-103287



Cut-off holder, adjustable, HP-IC

SH 32 48-110160R IC 80 bar
SH 32 48-110160L IC 80 bar



Boring bar holder, both sides, double, Y axis, short

Ø 25 48-98353

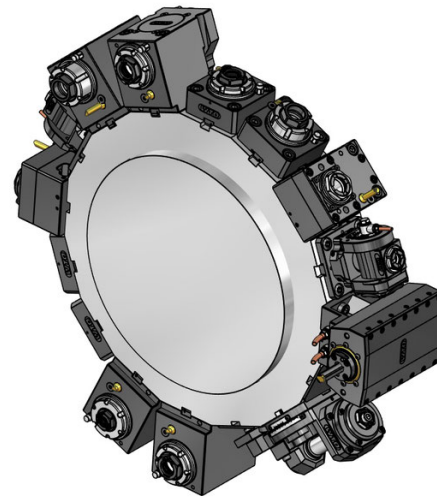
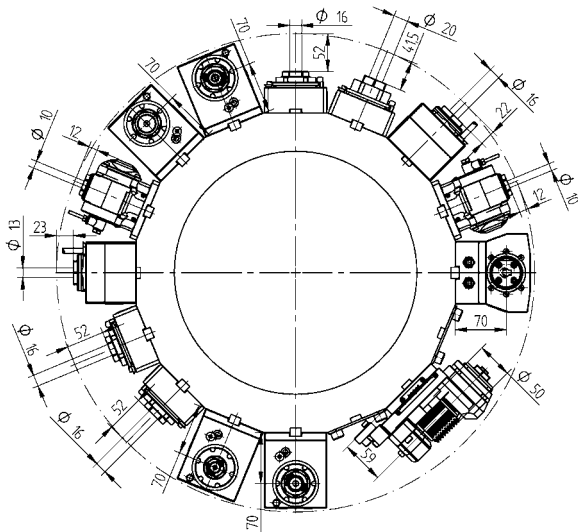

Driven Toolholders - QuickFlex®



Straight drill/milling unit

ER-25 QF 420125015-55 1:1 EC
0067725000

ER-25 QF 420125016-55 1:1 IC 80 bar
0067725000



Right angle drill/milling unit, LF=70

ER-25 QF 420525015-55 1:1 EC
0067725000

ER-25 QF 420525016-55 1:1 IC 80 bar
0067725000



Right angle drill/milling unit, both sides, LF=70

ER-25 QF 420525017-55 1:1 EC
0067725000

Driven Toolholders - Enhanced Program



Straight drill/milling unit

ER 32 410120010-55 1:1 EC
0067725000

ER 32 410120011-55 1:1 IC 80 bar
0067725000



Straight milling unit with combination mill arbor DIN 6358

Ø 22 410222004-55 1:1 EC
00675000483

Ø 3/4" 410219002-55 1:1 EC
00675000483



Straight offset drill/milling unit

ER 25 410116029-55 1:1 EC
00675000932

ER 25 410116030-55 1:1 IC 80 bar
00675000932

ER 20 410113009-55 1:2 EC
00675000939

ER 20 410113010-55 1:2 IC 80 bar
00675000939

ER 16 410410004-55 1:3 EC
00675000937

ER 16 410410005-55 1:3 IC 80 bar
00675000937

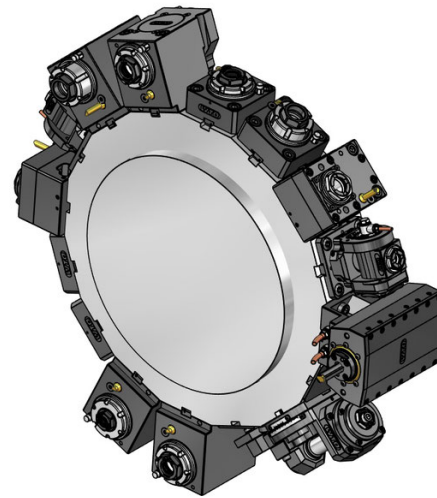
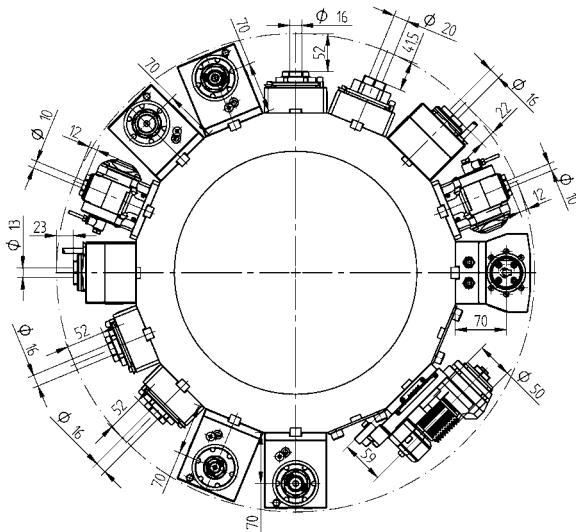

Driven Toolholders - Enhanced Program



Right angle drill/milling unit, LF=70

ER 32	410520033-55	1:1	EC
	0067725000		
ER 32	410520034-55	1:1	IC 80 bar
	0067725000		
ER-20 QF	420520012-55	1:2	EC
	0067720001		
ER-20 QF	420520013-55	1:2	IC 80 bar
	0067720001		
ER 16	410810016-55	1:3	EC
	00675000841		
ER 16	410810017-55	1:3	IC 80 bar
	00675000841		
ER-25 QF	420525030-55	2:1	EC
	0067725000		
ER-25 QF	420525031-55	2:1	IC 80 bar
	0067725000		



Right angle milling unit with combination mill arbor DIN 6358, LF=70

Ø 22	410622010-55	1:1	EC
	00675000483		
Ø 3/4"	410619005-55	1:1	EC
	00675000483		



Right angle back set drill/milling unit

ER 25	410516024-55	1:1	EC
	00675000801		
ER 25	410516025-55	1:1	IC 80 bar
	00675000801		

Driven Toolholders - Enhanced Program

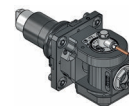

Adjustable angle drill/milling unit

ER 16	411010005-55	1:1	EC
	00675000902		
ER 16	411010006-55	1:1	IC 80 bar
	00675000902		
ER 11	411007007-55	1:2	EC
	00675000914		
ER 11	411007008-55	1:2	IC 80 bar
	00675000914		

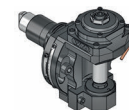

Gear hobbing unit

Type 15-2	410900002-55	1:1	EC
	00675001015		
	160008152 Ø 8		
	160010152 Ø 10		
	160013152 Ø 13		
	160016152 Ø 16		
	160022152 Ø 22		
	160015152 Ø 5/8"		
	160019152 Ø 3/4"		
	110587		

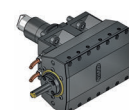

Broaching unit for ID and OD

TN765050	414532001-55	1:1	EC
-----------------	--------------	-----	----

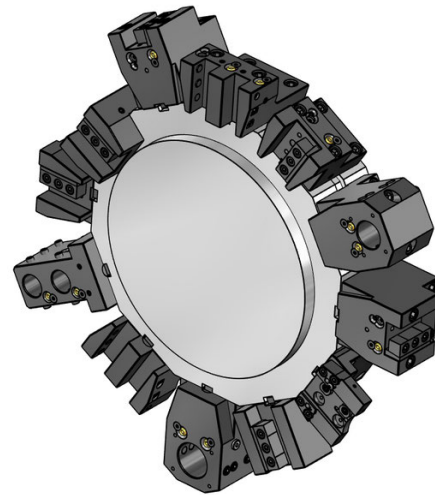
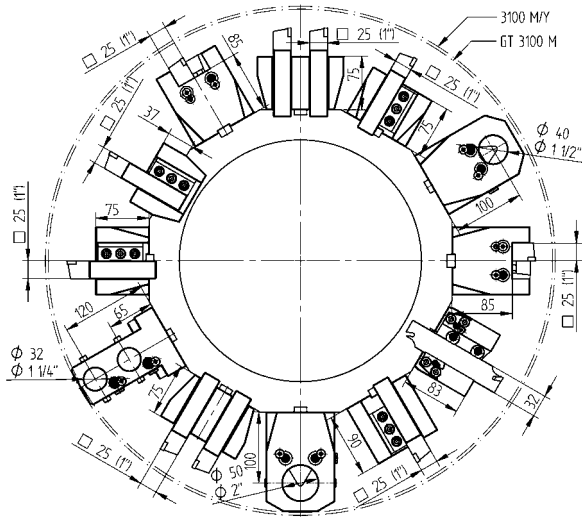

Static Toolholders - Standard Program

Static Toolholders - Enhanced Program

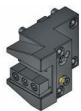

OD cutting holder

25 48-92428
1" 48-92466



OD cutting holder, HP-IC

25 48-92428-HP IC 80 bar
1" 48-92466-HP IC 80 bar



Face cutting holder, long

25 48-92958
1" 48-92959



Combination toolholder, LF=100

Ø 40 48-92397 IC 80 bar
 241140020 ER32
 241140026 ER40
Ø 50 48-92467 IC 80 bar
Ø 1 1/2" 48-92468 IC 80 bar
 2411150020 ER32
Ø 2" 48-92469 IC 80 bar



Boring bar holder, double

Ø 32 48-84524
Ø 1 1/4" 48-86905



Cover plate

48-87089

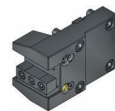

OD cutting holder, short

25 48-86991
1" 48-86992



OD cutting holder, short, HP-IC

25 48-86991-HP IC 80 bar
1" 48-86992-HP IC 80 bar

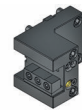

OD cutting holder, long

25 48-86711
1" 48-86712



OD cutting holder, double, Y axis

25(1") 48-86103



Cut-off holder, adjustable

SH 32 48-99060



Cut-off holder, adjustable, HP-IC

SH 32 48-102256R IC 80 bar
SH 32 48-102256L IC 80 bar



Cut-off holder, adjustable, long, HP-IC

SH 32 48-100082R IC 80 bar
SH 32 48-100082L IC 80 bar

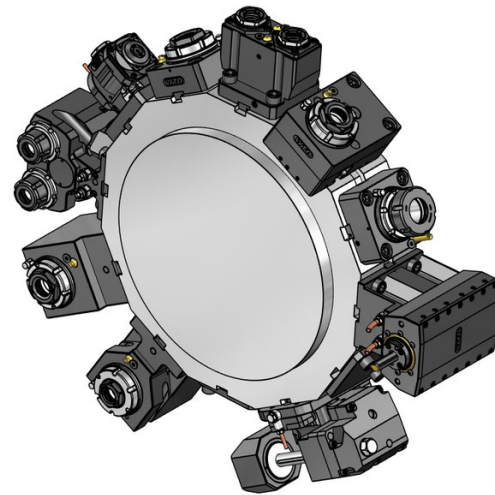
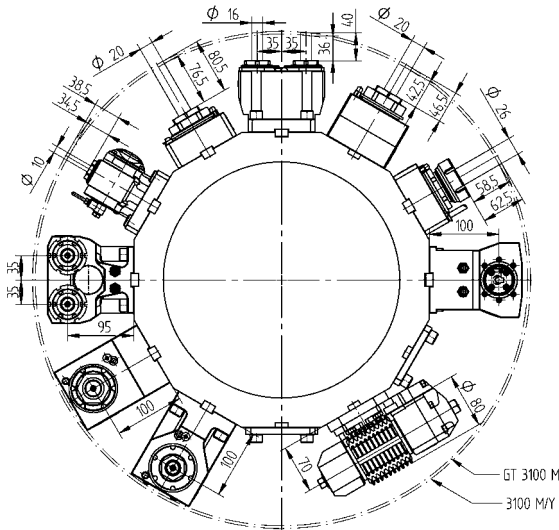

Driven Toolholders - QuickFlex®

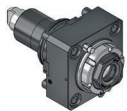

Straight drill/milling unit

ER-32 QF 420132015-65 1:1 EC
 ↳ 0067732000

ER-32 QF 420132016-65 1:1 IC 80 bar
 ↳ 0067732000



Right angle drill/milling unit, LF=100

ER-32 QF 420532018-65 1:1 EC
 ↳ 0067732000

ER-32 QF 420532019-65 1:1 IC 80 bar
 ↳ 0067732000

Driven Toolholders - Enhanced Program



Straight drill/milling unit

ER 40 410126001-65 1:1 EC
 ↳ 00675000079



Straight milling unit with combination mill arbor DIN 6358

Ø 22 410222002-65 1:1 EC
 ↳ 00675000483

Ø 1" 410225002-65 1:1 EC
 ↳ 00675000483



Straight offset drill/milling unit

ER-32 QF 420132037-65 1:1 EC
 ↳ 0067732000

ER-32 QF 420132038-65 1:1 IC 80 bar
 ↳ 0067732000

ER-25 QF 420125010-65 1:2 EC
 ↳ 0067725001

ER-25 QF 420125011-65 1:2 IC 80 bar
 ↳ 0067725001

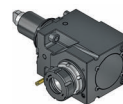

Right angle drill/milling unit, LF=100

ER 40 410526007-65 1:1 EC
 ↳ 00675000079

ER 40 410526008-65 1:1 IC 80 bar
 ↳ 00675000079



Right angle drill/milling unit, LF=100

ER-25 QF 420525012-65 1:2 EC
 ↳ 0067725001

ER-25 QF 420525013-65 1:2 IC 80 bar
 ↳ 0067725001

ER-32 QF 420532029-65 2:1 EC
 ↳ 0067732000

ER-32 QF 420532030-65 2:1 IC 80 bar
 ↳ 0067732000

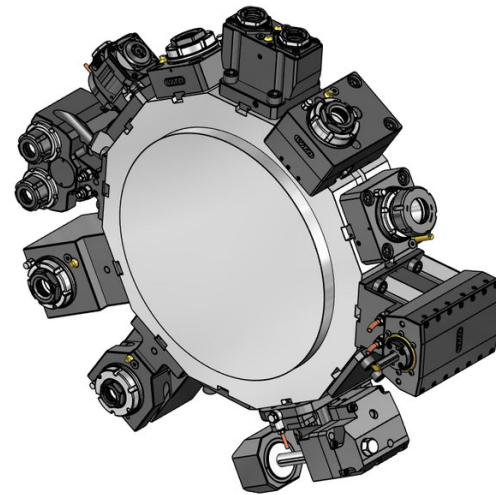
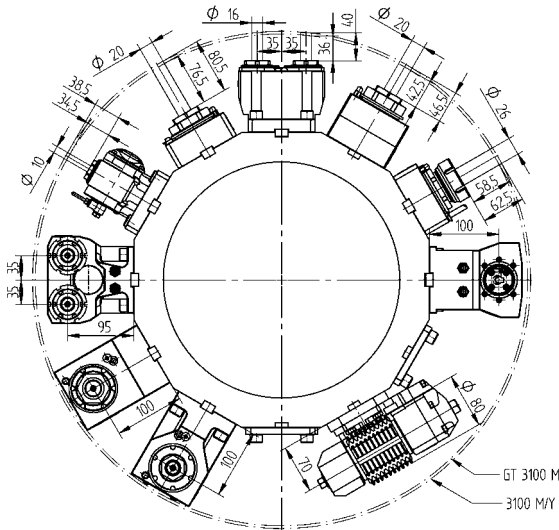

Driven Toolholders - Enhanced Program

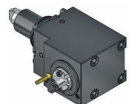

Right angle milling unit with combination mill arbor DIN 6358, LF=100

Ø 22	410622002-65	1:1	EC
	00675000483		
Ø 1"	410625002-65	1:1	EC
	00675000483		

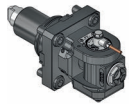

Adjustable angle drill/milling unit

ER 16	411010002-65	1:1	EC
	00675000902		
ER 16	411010003-65	1:1	IC 80 bar
	00675000902		
ER 11	411007002-65	1:2	EC
	00675000914		
ER 11	411007003-65	1:2	IC 80 bar
	00675000914		



Gear hobbing unit

Type 16-1	411500003-65	1:1	EC
Type 16-1	411500002-65	2:1	EC
	00675000927		
	160016161 Ø 16		
	160022161 Ø 22		
	160027161 Ø 27		
	160015161 Ø 5/8"		
	160019161 Ø 3/4"		
	160025161 Ø 1"		
	160031161 Ø 1 1/4"		
	110587		



Straight drill/milling unit, double, Y axis

ER 25	413002004-65	1:1	EC
	00675000907		

Driven Toolholders - Enhanced Program

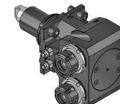

2-spindle - Right angle drill/milling unit, Y axis

ER 25	413502006-65	1:1	EC
	00675000915		
ER 25	413502007-65	1:1	IC 80 bar
	00675000915		

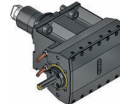

Broaching unit for ID and OD

TN765050	414532000-65	1:1	EC
-----------------	--------------	-----	----

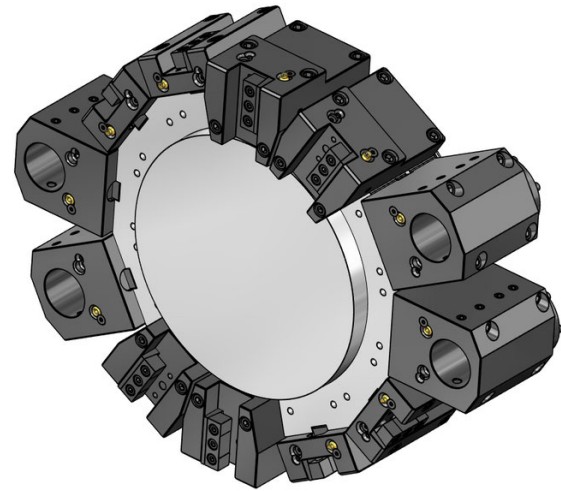
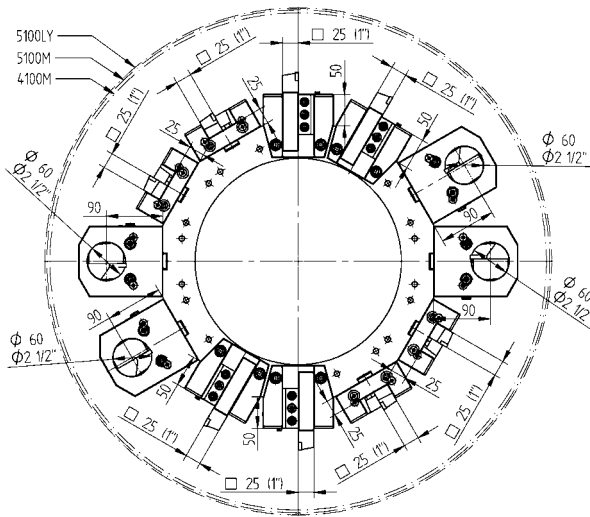

Static Toolholders - Standard Program

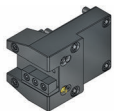

OD cutting holder
25 48-96421
1" 48-96422

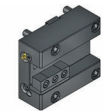

Face cutting holder
25 48-96355
1" 48-96357



Combination toolholder, LF=90
Ø 60 48-104448 IC 80 bar
Ø 2 1/2" 48-104449 IC 80 bar

Static Toolholders - Enhanced Program



OD cutting holder, double, Y axis
25(1") 48-112317



VDI adapter, right, LF=110
VDI 50 48-112600

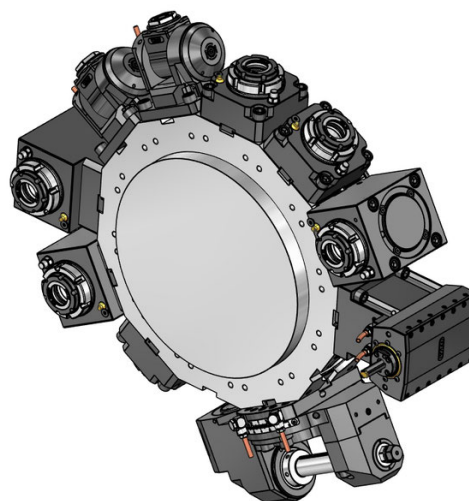
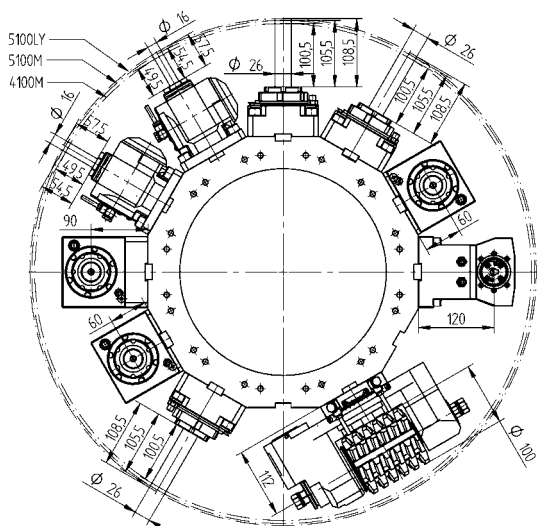

Driven Toolholders - QuickFlex®

Driven Toolholders - Enhanced Program



OD drill/milling unit

- ER-40 QF** 420140015-75 1:1 EC
0067740000
- ER-40 QF** 420140016-75 1:1 IC 80 bar
0067740000



Face drill/milling unit, LF=60

- ER-40 QF** 420540015-75 1:1 EC
0067740000
- ER-40 QF** 420540016-75 1:1 IC 80 bar
0067740000



Face drill/milling unit, LF=90

- ER-40 QF** 420540017-75 1:1 EC
0067740000
- ER-40 QF** 420540018-75 1:1 IC 80 bar
0067740000



Face drill/milling unit, LF=60

- ER-32 QF** 420532010-75 1:2 EC
0067732001
- ER-32 QF** 420532011-75 1:2 IC 80 bar
0067732001
- ER-40 QF** 420540021-75 2:1 EC
0067740000
- ER-40 QF** 420540022-75 2:1 IC 80 bar
0067740000



Adjustable angle drill/milling unit

- ER 25** 411016000-75 1:1 EC
00675000934
- ER 25** 411016001-75 1:1 IC 80 bar
00675000934
- ER 16** 411010002-75 1:2 EC
00675000936
- ER 16** 411010003-75 1:2 IC 80 bar
00675000936



Gear hobbing unit

- Type C5-1** 410900001-75 2:1 EC
00675001008
- 160022C51 Ø 22
- 160027C51 Ø 27
- 160032C51 Ø 32
- 160015C51 Ø 5/8"
- 160019C51 Ø 3/4"
- 160025C51 Ø 1"
- 160031C51 Ø 1 1/4"

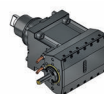

Broaching unit for ID and OD

- TN765050** 414532000-75 1:1 EC

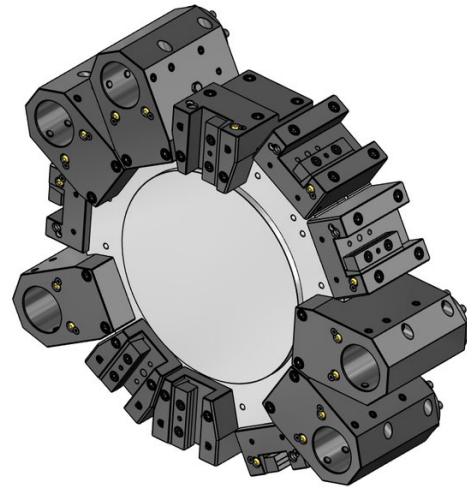
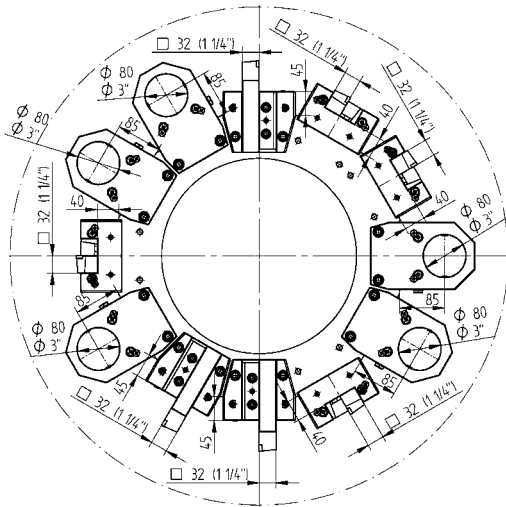

Static Toolholders - Standard Program



OD cutting holder

- 32** 48-95667
- 1 1/4"** 48-95668



Face cutting holder

- 32** 48-95669
- 1 1/4"** 48-95670



Combination toolholder

- $\phi 80$** 48-95671 IC 80 bar
- $\phi 3''$** 48-95672 IC 80 bar

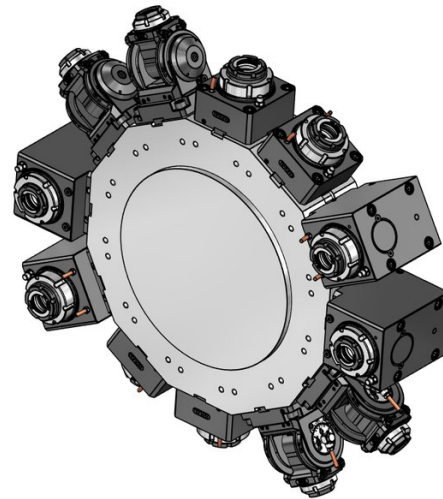
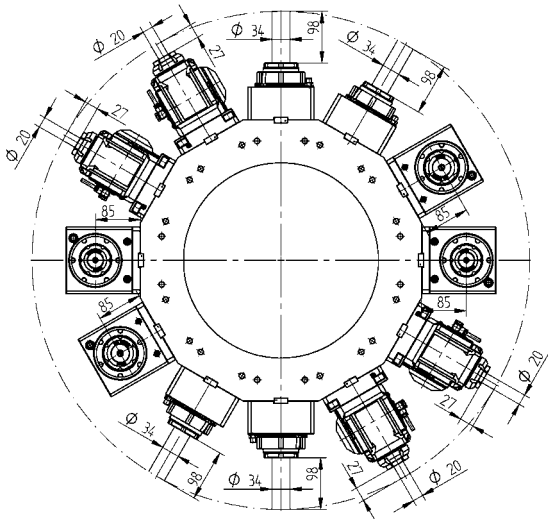

Driven Toolholders - QuickFlex®



OD drill/milling unit

- | | | | |
|-----------------|--------------|-----|-----------|
| ER-50 QF | 420150015-85 | 1:1 | EC |
| | 0067750000 | | |
| ER-50 QF | 420150016-85 | 1:1 | IC 80 bar |
| | 0067750000 | | |



Face drill/milling unit, LF=85

- | | | | |
|-----------------|--------------|-----|-----------|
| ER-50 QF | 420550015-85 | 1:1 | EC |
| | 0067750000 | | |
| ER-50 QF | 420550016-85 | 1:1 | IC 80 bar |
| | 0067750000 | | |

Driven Toolholders - Enhanced Program



Face drill/milling unit, LF=85

- | | | | |
|-----------------|--------------|-----|-----------|
| ER-40 QF | 420540015-85 | 1:2 | EC |
| | 0067740001 | | |
| ER-40 QF | 420540016-85 | 1:2 | IC 80 bar |
| | 0067740001 | | |

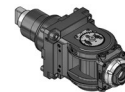

Adjustable angle drill/milling unit

- | | | | |
|-----------------|--------------|-----|-----------|
| ER-32 QF | 421032010-85 | 1:1 | EC |
| | 00675000976 | | |
| ER-32 QF | 421032011-85 | 1:1 | IC 80 bar |
| | 00675000976 | | |



Gear hobbing unit

- | | | | |
|------------------|--------------------|-----|----|
| Type C5-1 | 410900000-85 | 2:1 | EC |
| | 00675001008 | | |
| | 160022C51 Ø 22 | | |
| | 160027C51 Ø 27 | | |
| | 160032C51 Ø 32 | | |
| | 160019C51 Ø 3/4" | | |
| | 160025C51 Ø 1" | | |
| | 160031C51 Ø 1 1/4" | | |

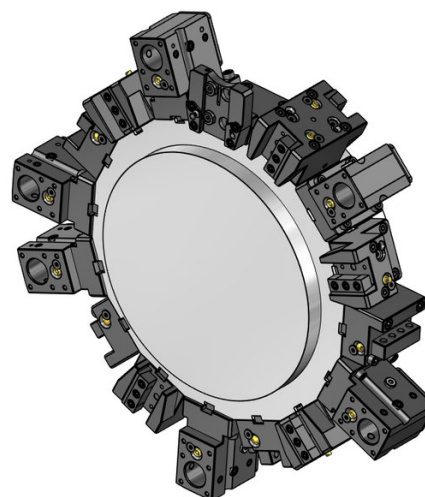
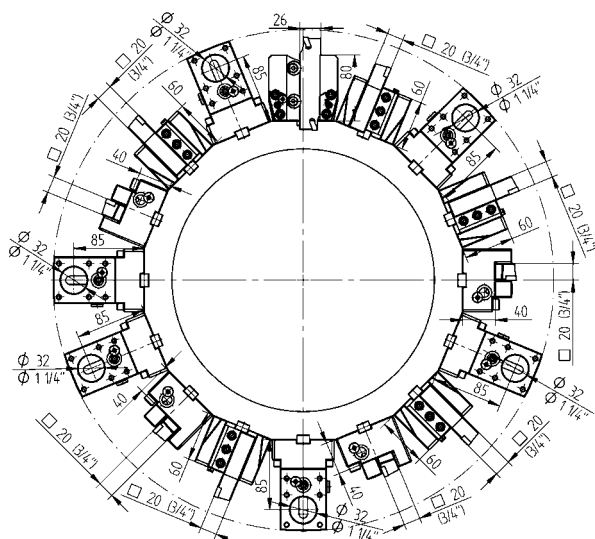

Static Toolholders - Standard Program

Static Toolholders - Standard Program



OD cutting holder

- 20 48-95083
- 3/4" 48-95084

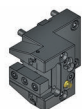

OD cutting holder, HP-IC

- 20 48-100605-HP IC 80 bar
- 25 48-104395-HP IC 80 bar
- 3/4" 48-108926-HP IC 80 bar
- 1" 48-104396-HP IC 80 bar

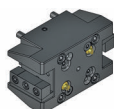

OD cutting holder, both sides

- 20 48-95085
- 3/4" 48-95086

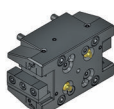

OD cutting holder, both sides, HP-IC

- 20 48-95085-HP IC 80 bar
- 3/4" 48-95086-HP IC 80 bar

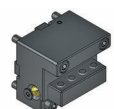

Face cutting holder

- 20 48-109148

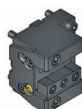

Face cutting holder

- 3/4" 48-95338



Face cutting holder, HP-IC

- 20 48-109148-HP IC 80 bar
- 25 48-104397-HP IC 80 bar
- 3/4" 48-109149-HP IC 80 bar
- 1" 48-104398-HP IC 80 bar



Combination toolholder, universal, LF=85

- Ø 32 48-95998 IC 80 bar
- 241132016 ER25
- 241132020 ER32
- Ø 1 1/4" 48-96029 IC 80 bar
- 2411125020 ER32

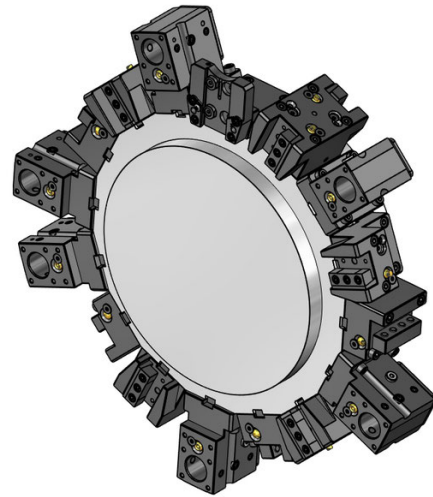
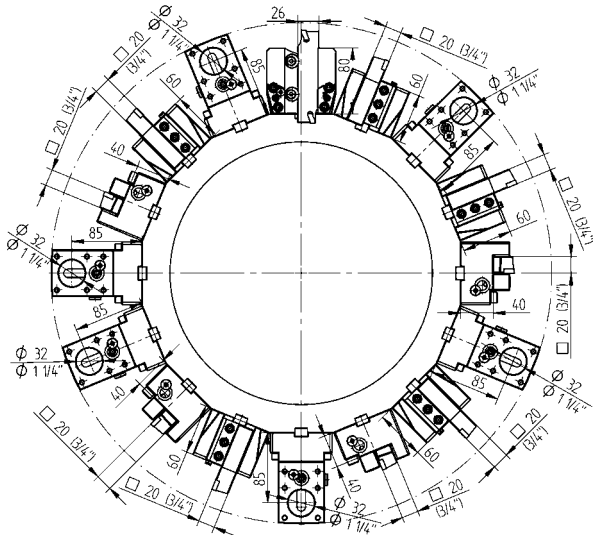

Static Toolholders - Enhanced Program



Cut-off holder, adjustable

SH 26 48-94968



Cut-off holder, adjustable, HP-IC

SH 26 48-102252R IC 80 bar

SH 26 48-102252L IC 80 bar

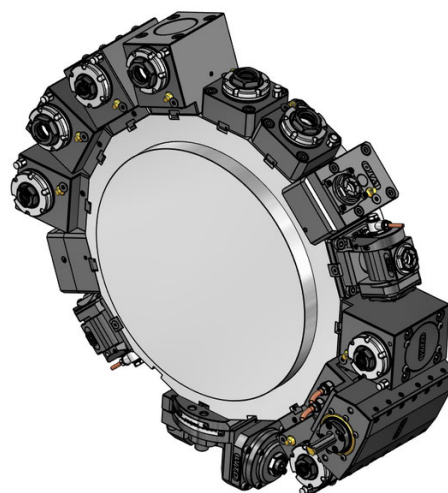
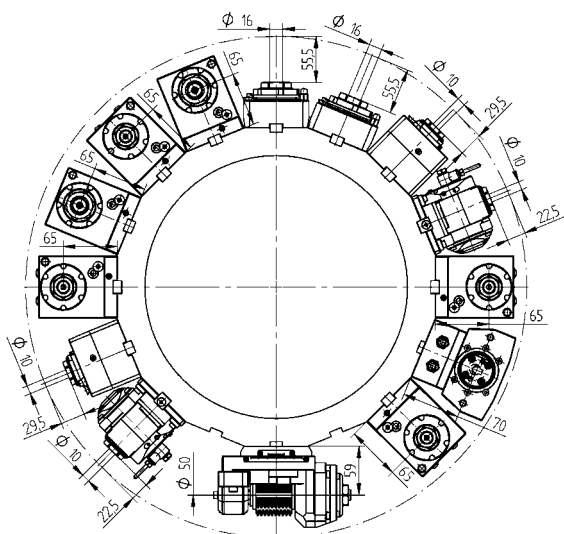

Driven Toolholders - QuickFlex®



Straight drill/milling unit

- ER-25 QF** 420125015-45 1:1 EC
0067725000
- ER-25 QF** 420125016-45 1:1 IC 80 bar
0067725000



Right angle drill/milling unit

- ER-25 QF** 420525015-45 1:1 EC
0067725000
- ER-25 QF** 420525016-45 1:1 IC 80 bar
0067725000

Driven Toolholders - Enhanced Program



Straight offset drill/milling unit

- ER 16** 410410008-45 1:3 EC
00675000937
- ER 16** 410410002-45 1:3 IC 80 bar
00675000937



Right angle drill/milling unit

- ER-20 QF** 420520018-45 1:2 EC
0067720001
- ER-20 QF** 420520019-45 1:2 IC 80 bar
0067720001
- ER-25 QF** 420525020-45 2:1 EC
0067725000
- ER-25 QF** 420525021-45 2:1 IC 80 bar
0067725000

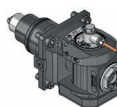

Adjustable angle drill/milling unit

- ER 16** 411010002-45 1:1 EC
00675000902
- ER 16** 411010003-45 1:1 IC 80 bar
00675000902
- ER 11** 411007004-45 1:2 EC
00675000914
- ER 11** 411007005-45 1:2 IC 80 bar
00675000914

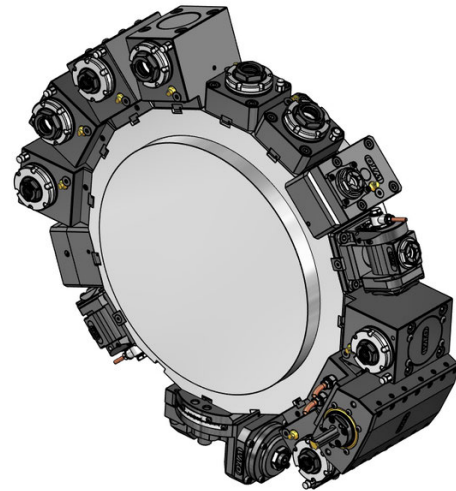
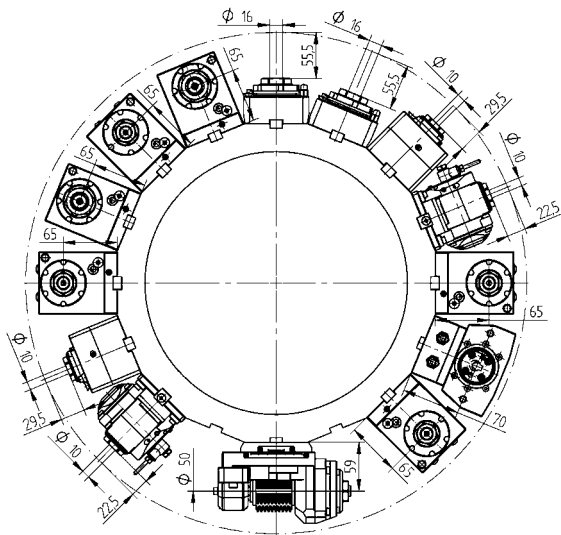

Driven Toolholders - Enhanced Program



Gear hobbing unit

Type 15-2 410900001-45 1:1 EC

-  00675001015
-  160008152 Ø 8
-  160010152 Ø 10
-  160013152 Ø 13
-  160016152 Ø 16
-  160022152 Ø 22
-  160015152 Ø 5/8"
-  160019152 Ø 3/4"
-  110587



Broaching unit for ID and OD

TN765050 414532000-45 1:1 EC

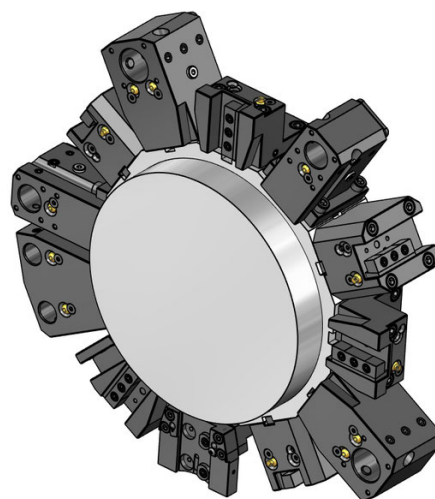
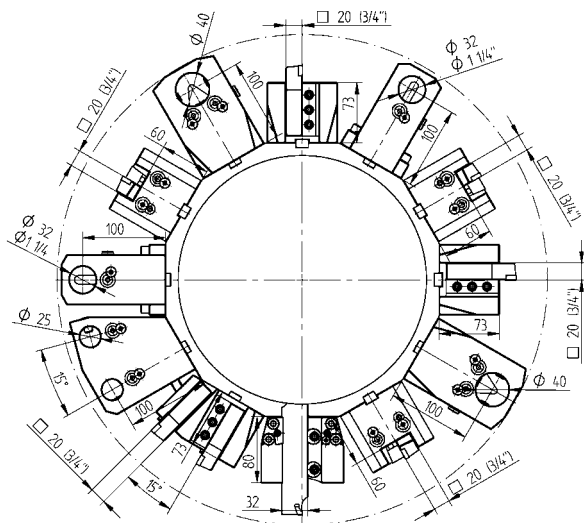



Static Toolholders - Standard Program

Static Toolholders - Enhanced Program

- 

OD cutting holder
 20 48-92036
 3/4" 48-92037
- 

OD cutting holder, HP-IC
 20 48-92036-HP IC 80 bar
 3/4" 48-92037-HP IC 80 bar
- 

OD cutting holder, both sides
 20 48-92038
 3/4" 48-92039
- 

OD cutting holder, both sides, HP-IC
 20 48-92038-HP IC 80 bar
 3/4" 48-92039-HP IC 80 bar
- 

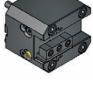
Face cutting holder
 20 48-92045
 3/4" 48-92046
- 

Face cutting holder, HP-IC
 20 48-92045-HP IC 80 bar
 3/4" 48-92046-HP IC 80 bar
- 

Combination toolholder, universal, LF=100
 Ø 32 48-92043 IC 80 bar
 241132016 ER25
 241132020 ER32
 Ø 1 1/4" 48-92044 IC 80 bar
 2411125020 ER32
- 

Combination toolholder, universal, LF=100
 Ø 40 48-103474 IC 80 bar
 241140020 ER32
 241140026 ER40

- 

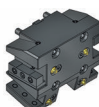
OD cutting holder, double, 24 station
 20 48-87674
- 

OD cutting holder, both sides, double, 24 station
 20 48-92980
- 

Cut-off holder, adjustable
 SH 32 48-103287
- 

Cut-off holder, adjustable, HP-IC
 SH 32 48-110160R IC 80 bar
 SH 32 48-110160L IC 80 bar
- 

Cut-off holder, adjustable, long
 SH 32 48-103288
- 

Cut-off holder, adjustable, long, HP-IC
 SH 32 48-111142R IC 80 bar
 343-810100R90
 SH 32 48-111142L IC 80 bar
 343-810100L90
- 

Boring bar holder, double, 24 station
 Ø 25 48-87678

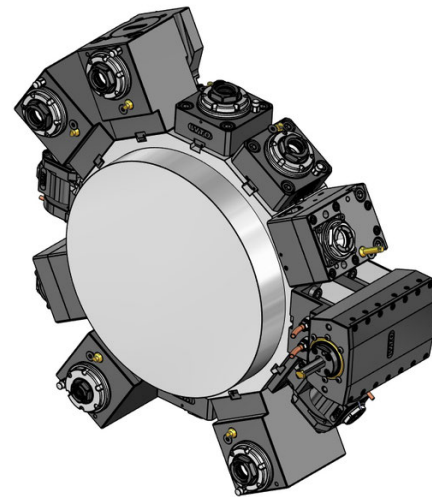
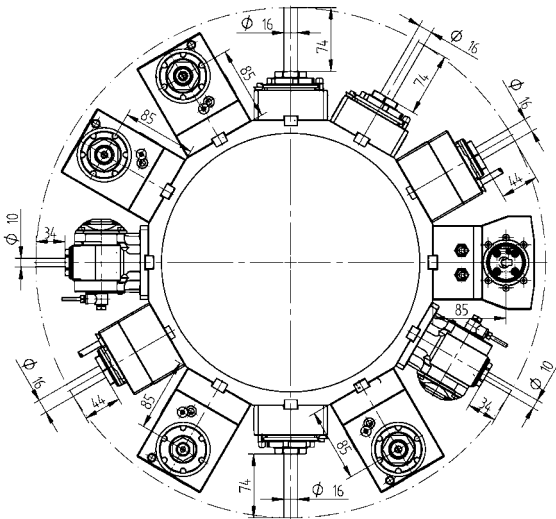

Driven Toolholders - QuickFlex®



Straight drill/milling unit

ER-25 QF 420125015-55 1:1 EC
 ↳ 0067725000

ER-25 QF 420125016-55 1:1 IC 80 bar
 ↳ 0067725000



Right angle drill/milling unit, LF=85

ER-25 QF 420525018-55 1:1 EC
 ↳ 0067725000

ER-25 QF 420525019-55 1:1 IC 80 bar
 ↳ 0067725000



Right angle drill/milling unit, both sides, LF=85

ER-25 QF 420525020-55 1:1 EC
 ↳ 0067725000

Driven Toolholders - Enhanced Program



Straight drill/milling unit

ER 32 410120010-55 1:1 EC
 ↳ 0067725000

ER 32 410120011-55 1:1 IC 80 bar
 ↳ 0067725000



Straight milling unit with combination mill arbor DIN 6358

Ø 22 410222004-55 1:1 EC
 ↳ 00675000483

Ø 3/4" 410219002-55 1:1 EC
 ↳ 00675000483



Straight offset drill/milling unit

ER 25 410116029-55 1:1 EC
 ↳ 00675000932

ER 25 410116030-55 1:1 IC 80 bar
 ↳ 00675000932

ER 20 410113009-55 1:2 EC
 ↳ 00675000939

ER 20 410113010-55 1:2 IC 80 bar
 ↳ 00675000939

ER 16 410410004-55 1:3 EC
 ↳ 00675000937

ER 16 410410005-55 1:3 IC 80 bar
 ↳ 00675000937

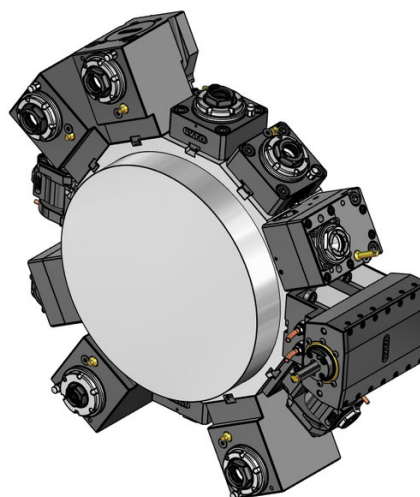
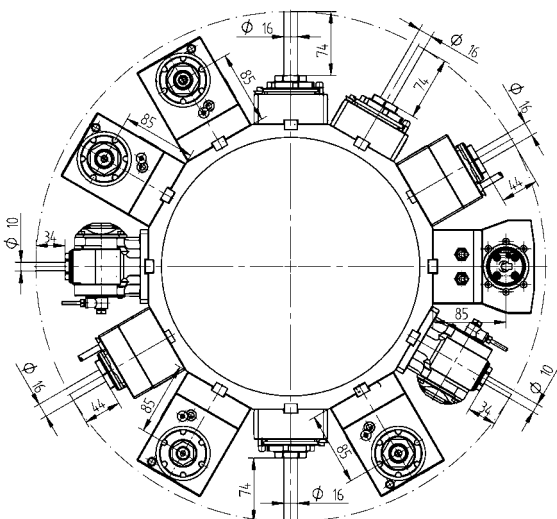

Driven Toolholders - Enhanced Program



Right angle drill/milling unit, LF=85

ER 32	410520030-55	1:1	EC
	0067725000		
ER 32	410520031-55	1:1	IC 80 bar
	0067725000		
ER-20 QF	420520014-55	1:2	EC
	0067720001		
ER-20 QF	420520015-55	1:2	IC 80 bar
	0067720001		
ER 16	410810020-55	1:3	EC
	00675000841		
ER 16	410810021-55	1:3	IC 80 bar
	00675000841		
ER-25 QF	420525032-55	2:1	EC
	0067725000		
ER-25 QF	420525033-55	2:1	IC 80 bar
	0067725000		



Right angle milling unit with combination mill arbor DIN 6358, LF=85

Ø 22	410622011-55	1:1	EC
	00675000483		
Ø 3/4"	410619006-55	1:1	EC
	00675000483		



Adjustable angle drill/milling unit

ER 16	411010005-55	1:1	EC
	00675000902		
ER 16	411010006-55	1:1	IC 80 bar
	00675000902		
ER 11	411007007-55	1:2	EC
	00675000914		
ER 11	411007008-55	1:2	IC 80 bar
	00675000914		

Driven Toolholders - Enhanced Program

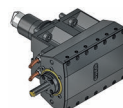

Broaching unit for ID and OD

TN765050	414532000-55	1:1	EC
-----------------	--------------	-----	----

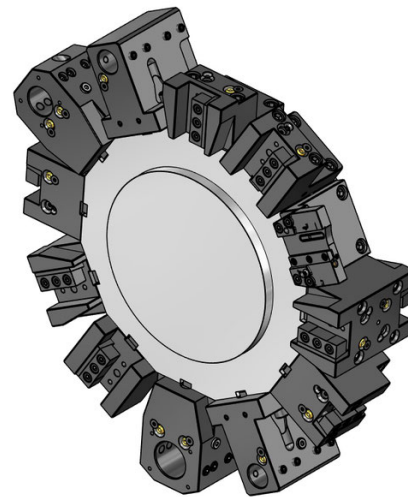
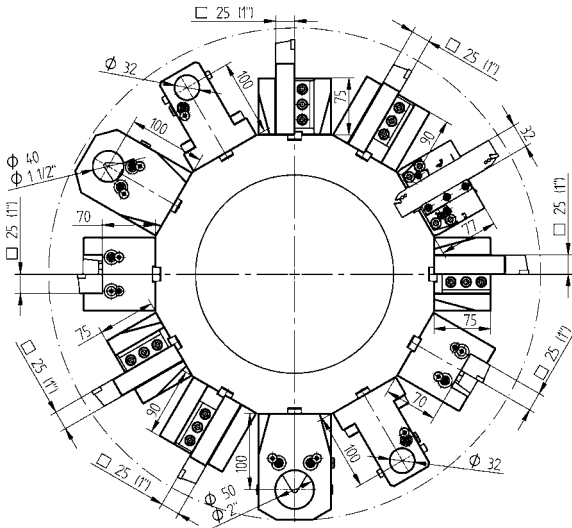

Static Toolholders - Standard Program

Static Toolholders - Standard Program

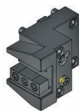

OD cutting holder

25 48-92428
1" 48-92466



OD cutting holder, HP-IC

25 48-92428-HP IC 80 bar
1" 48-92466-HP IC 80 bar



OD cutting holder, long

25 48-86711
1" 48-86712



OD cutting holder, both sides

25 48-92438
1" 48-92472



OD cutting holder, both sides, HP-IC

25 48-92438-HP IC 80 bar
1" 48-92472-HP IC 80 bar



OD cutting holder, both sides, long

25 48-84523
1" 48-86718



Face cutting holder

25 48-86719
1" 48-86720



Face cutting holder, HP-IC

25 48-109249-HP IC 80 bar
1" 48-109250-HP IC 80 bar



Combination toolholder, LF=100

Ø 40 48-92397 IC 80 bar
241140020 ER32
241140026 ER40
Ø 50 48-92467 IC 80 bar
Ø 1 1/2" 48-92468 IC 80 bar
2411150020 ER32
Ø 2" 48-92469 IC 80 bar

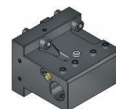

Boring bar holder, both sides

Ø 32 48-101033
Ø 1 1/4" 48-113514



Cover plate

48-87089

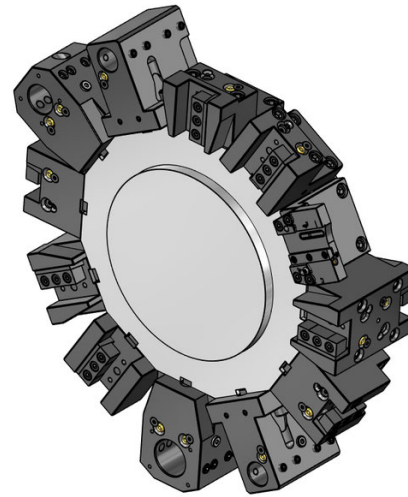
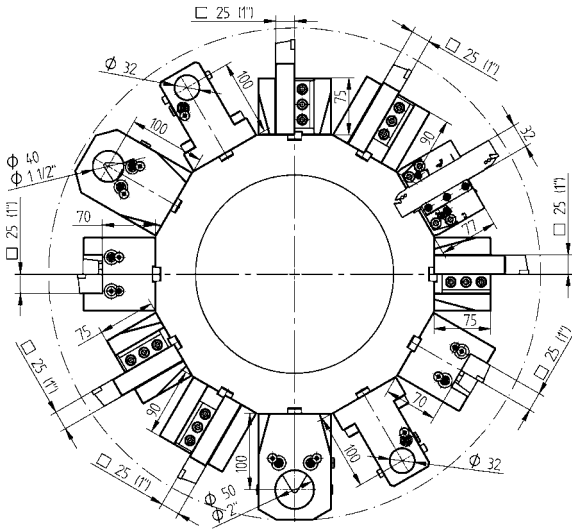

Static Toolholders - Enhanced Program



Cut-off holder, adjustable

SH 32 48-99060



Cut-off holder, adjustable, long

SH 32 48-100084



Cut-off holder, adjustable, HP-IC

SH 32 48-102256R IC 80 bar
SH 32 48-102256L IC 80 bar



Cut-off holder, adjustable, long, HP-IC

SH 32 48-100082R IC 80 bar
SH 32 48-100082L IC 80 bar

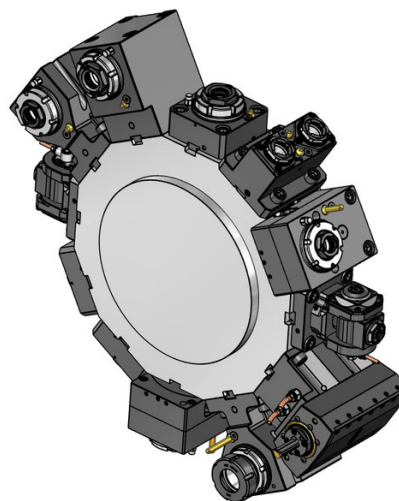
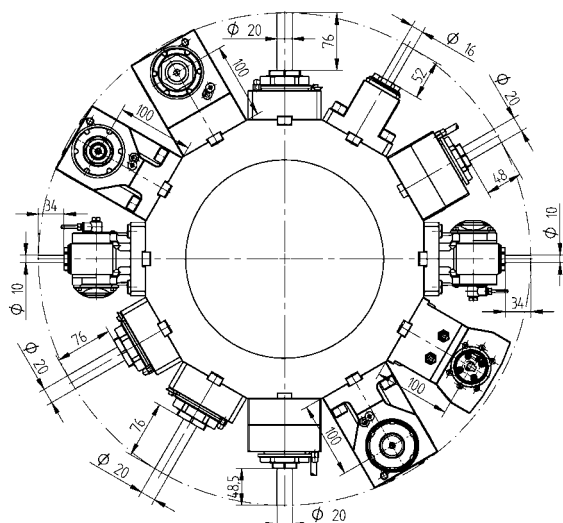

Driven Toolholders - QuickFlex®

- 

Straight drill/milling unit
ER-32 QF 420132015-65 1:1 EC
 0067732000

ER-32 QF 420132016-65 1:1 IC 80 bar
 0067732000
- 

Right angle drill/milling unit, LF=100
ER-32 QF 420532018-65 1:1 EC
 0067732000

ER-32 QF 420532019-65 1:1 IC 80 bar
 0067732000
- 

Right angle drill/milling unit, both sides, LF=100
ER-32 QF 420532020-65 1:1 EC
 0067732000

Driven Toolholders - Enhanced Program

- 

Straight drill/milling unit
ER 40 410126001-65 1:1 EC
 00675000079
- 

Straight milling unit with combination mill arbor DIN 6358
Ø 22 410222002-65 1:1 EC
 00675000483

Ø 1" 410225002-65 1:1 EC
 00675000483
- 

Straight offset drill/milling unit
ER-32 QF 420132037-65 1:1 EC
 0067732000

ER-32 QF 420132038-65 1:1 IC 80 bar
 0067732000

ER-25 QF 420125010-65 1:2 EC
 0067725001

ER-25 QF 420125011-65 1:2 IC 80 bar
 0067725001
- 

Right angle drill/milling unit, LF=100
ER 40 410526007-65 1:1 EC
 00675000079

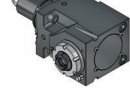
ER 40 410526008-65 1:1 IC 80 bar
 00675000079
- 

Right angle drill/milling unit, LF=100
ER-25 QF 420525012-65 1:2 EC
 0067725001

ER-25 QF 420525013-65 1:2 IC 80 bar
 0067725001

ER-32 QF 420532029-65 2:1 EC
 0067732000

ER-32 QF 420532030-65 2:1 IC 80 bar
 0067732000

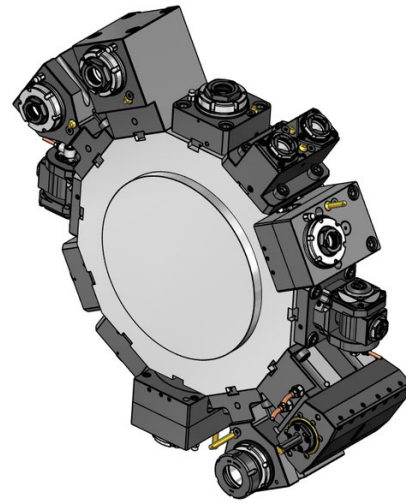
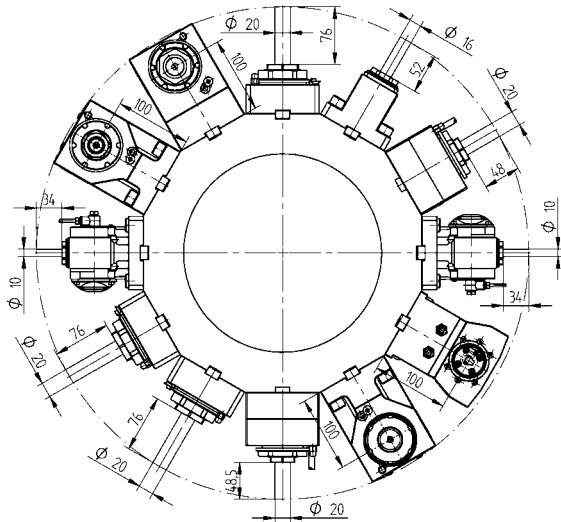

Driven Toolholders - Enhanced Program

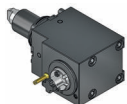

Right angle milling unit with combination mill arbor DIN 6358, LF=100

Ø 22	410622002-65	1:1	EC
	00675000483		
Ø 1"	410625002-65	1:1	EC
	00675000483		

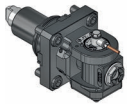

Adjustable angle drill/milling unit

ER 16	411010002-65	1:1	EC
	00675000902		
ER 16	411010003-65	1:1	IC 80 bar
	00675000902		
ER 11	411007002-65	1:2	EC
	00675000914		
ER 11	411007003-65	1:2	IC 80 bar
	00675000914		



Straight drill/milling unit, both sides

ER 25	413002001-65	1:1	EC
	00675000907		



Broaching unit for ID and OD

TN765050	414532000-65	1:1	EC
-----------------	--------------	-----	----

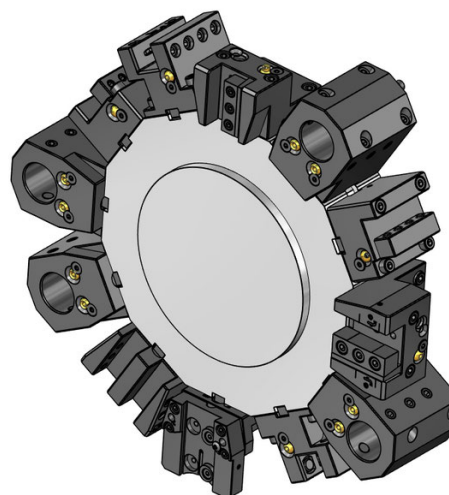
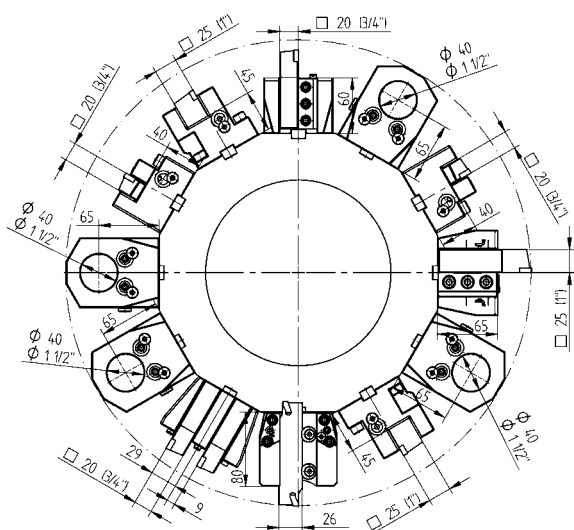

Static Toolholders - Standard Program

Static Toolholders - Enhanced Program

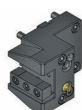

OD cutting holder

20 48-95083
3/4" 48-95084

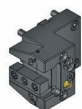

OD cutting holder, HP-IC

20 48-100605-HP IC 80 bar
25 48-104395-HP IC 80 bar
3/4" 48-108926-HP IC 80 bar
1" 48-104396-HP IC 80 bar

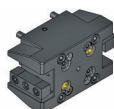

OD cutting holder, both sides

20 48-95085
3/4" 48-95086

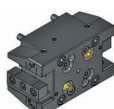

OD cutting holder, both sides, HP-IC

20 48-95085-HP IC 80 bar
3/4" 48-95086-HP IC 80 bar

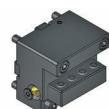

Face cutting holder

20 48-109148

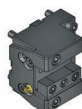

Face cutting holder

3/4" 48-95338

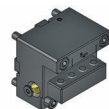

Face cutting holder, HP-IC

20 48-109148-HP IC 80 bar
25 48-104397-HP IC 80 bar
3/4" 48-109149-HP IC 80 bar
1" 48-104398-HP IC 80 bar



Combination toolholder, LF=65

Ø 40 48-95090 IC 80 bar
Ø 1 1/2" 48-95327 IC 80 bar



OD cutting holder, both sides, double, Y axis

20 (3/4") 48-110811



Cut-off holder, adjustable

SH 26 48-94968



Cut-off holder, adjustable, HP-IC

SH 26 48-102252R IC 80 bar
SH 26 48-102252L IC 80 bar

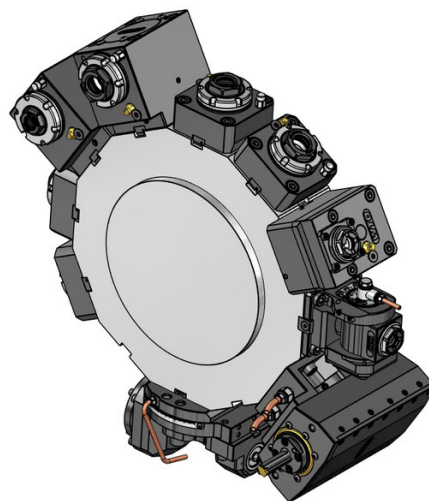
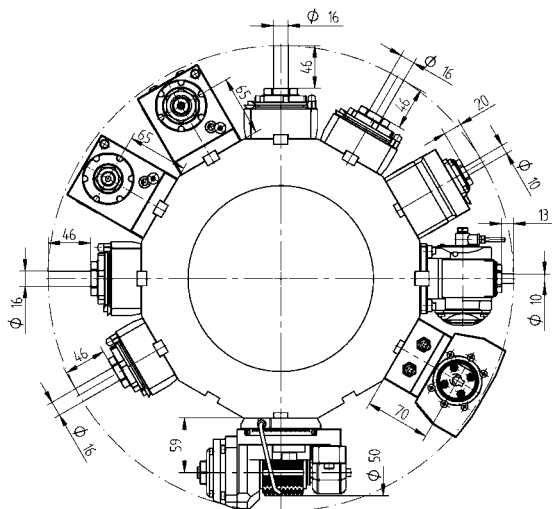

Driven Toolholders - QuickFlex®



Straight drill/milling unit

ER-25 QF 420125015-45 1:1 EC
 0067725000

ER-25 QF 420125016-45 1:1 IC 80 bar
 0067725000



Straight drill/milling unit (12000 RPM)

ER-25 QF 420125019-45 1:1 EC
 0067725000

ER-25 QF 420125020-45 1:1 IC 80 bar
 0067725000



Right angle drill/milling unit

ER-25 QF 420525015-45 1:1 EC
 0067725000

ER-25 QF 420525016-45 1:1 IC 80 bar
 0067725000



Right angle drill/milling unit (12000 RPM)

ER-25 QF 420525038-45 1:1 EC
 0067725000

ER-25 QF 420525039-45 1:1 IC 80 bar
 0067725000

Driven Toolholders - Enhanced Program



Straight offset drill/milling unit

ER 16 410410008-45 1:3 EC
 00675000937

ER 16 410410002-45 1:3 IC 80 bar
 00675000937



Right angle drill/milling unit

ER-20 QF 420520018-45 1:2 EC
 0067720001

ER-20 QF 420520019-45 1:2 IC 80 bar
 0067720001

ER-25 QF 420525020-45 2:1 EC
 0067725000

ER-25 QF 420525021-45 2:1 IC 80 bar
 0067725000

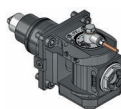

Adjustable angle drill/milling unit

ER 16 411010002-45 1:1 EC
 00675000902

ER 16 411010003-45 1:1 IC 80 bar
 00675000902

ER 11 411007004-45 1:2 EC
 00675000914

ER 11 411007005-45 1:2 IC 80 bar
 00675000914

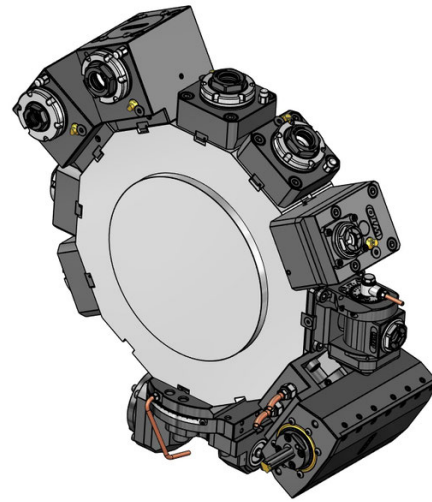
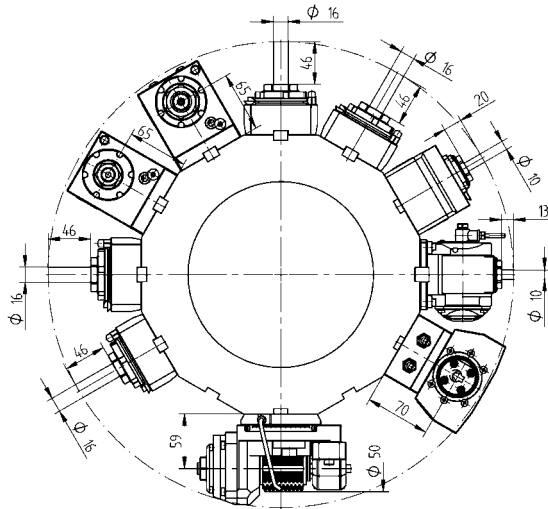

Driven Toolholders - Enhanced Program



Gear hobbing unit

Type 15-2 410900001-45 1:1 EC

- 00675001015
- 160008152 Ø 8
- 160010152 Ø 10
- 160013152 Ø 13
- 160016152 Ø 16
- 160022152 Ø 22
- 160015152 Ø 5/8"
- 160019152 Ø 3/4"
- 110587



Straight drill/milling unit, double, Y axis

ER 20 413002006-45 1:1 EC

- 00675000947

ER 20 413002008-45 1:1 IC 80 bar

- 00675000947

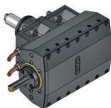

Broaching unit for ID and OD

TN765050 414532000-45 1:1 EC

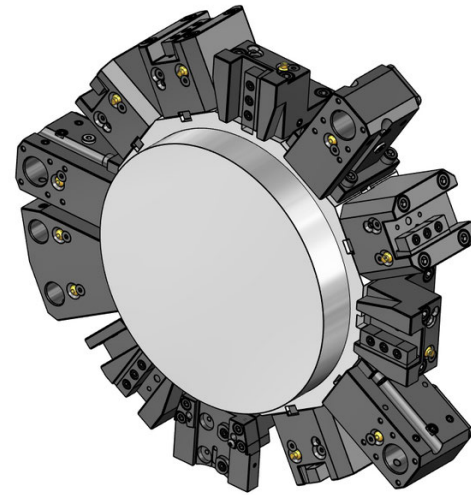
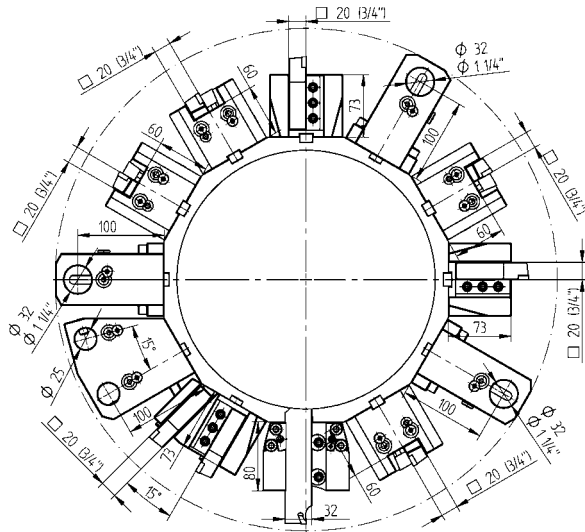



Static Toolholders - Standard Program

Static Toolholders - Enhanced Program

- 

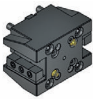
OD cutting holder
 20 48-92036
 3/4" 48-92037
- 

OD cutting holder, HP-IC
 20 48-92036-HP IC 80 bar
 3/4" 48-92037-HP IC 80 bar
- 

OD cutting holder, both sides
 20 48-92038
 3/4" 48-92039
- 

OD cutting holder, both sides, HP-IC
 20 48-92038-HP IC 80 bar
 3/4" 48-92039-HP IC 80 bar
- 

Face cutting holder
 20 48-92045
 3/4" 48-92046
- 

Face cutting holder, HP-IC
 20 48-92045-HP IC 80 bar
 3/4" 48-92046-HP IC 80 bar
- 

Combination toolholder, universal, LF=100
 Ø 32 48-92043 IC 80 bar
 241132016 ER25
 241132020 ER32
 Ø 1 1/4" 48-92044 IC 80 bar
 2411125020 ER32
- 

Cover plate
 48-87111

- 

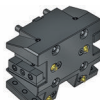
OD cutting holder, double, 24 station
 20 48-87674
- 

OD cutting holder, both sides, double, 24 station
 20 48-92980
- 

Cut-off holder, adjustable
 SH 32 48-103287
- 

Cut-off holder, adjustable, HP-IC
 SH 32 48-110160R IC 80 bar
 SH 32 48-110160L IC 80 bar
- 

Cut-off holder, adjustable, long
 SH 32 48-103288
- 

Cut-off holder, adjustable, long, HP-IC
 SH 32 48-111142R IC 80 bar
 343-810100R90
 SH 32 48-111142L IC 80 bar
 343-810100L90
- 

Boring bar holder, double, 24 station
 Ø 25 48-87678

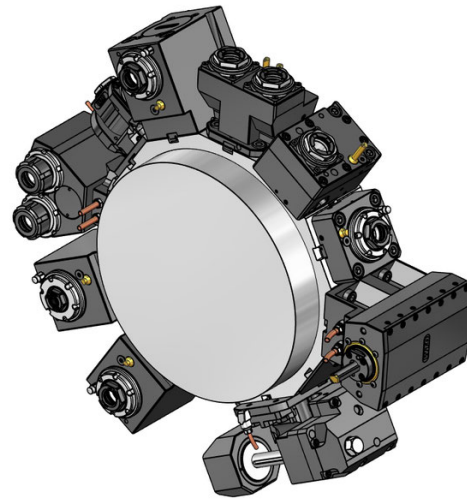
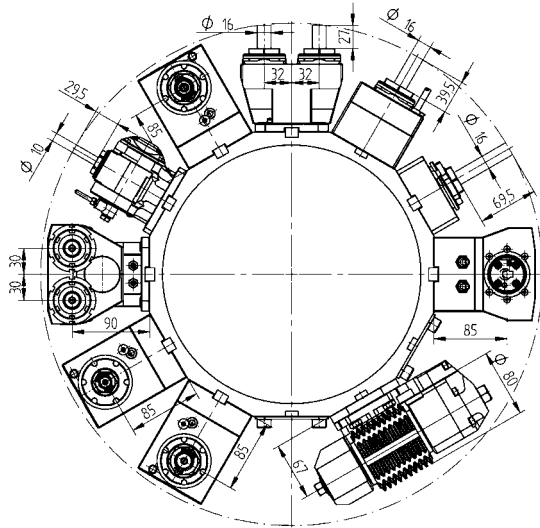

Driven Toolholders - QuickFlex®



Straight drill/milling unit

ER-25 QF 420125015-55 1:1 EC
 0067725000

ER-25 QF 420125016-55 1:1 IC 80 bar
 0067725000



Right angle drill/milling unit, LF=85

ER-25 QF 420525018-55 1:1 EC
 0067725000

ER-25 QF 420525019-55 1:1 IC 80 bar
 0067725000



Right angle drill/milling unit, both sides, LF=85

ER-25 QF 420525020-55 1:1 EC
 0067725000

Driven Toolholders - Enhanced Program



Straight drill/milling unit

ER 32 410120010-55 1:1 EC
 0067725000

ER 32 410120011-55 1:1 IC 80 bar
 0067725000



Straight milling unit with combination mill arbor DIN 6358

Ø 22 410222004-55 1:1 EC
 00675000483

Ø 3/4" 410219002-55 1:1 EC
 00675000483



Straight offset drill/milling unit

ER 25 410116029-55 1:1 EC
 00675000932

ER 25 410116030-55 1:1 IC 80 bar
 00675000932

ER 20 410113009-55 1:2 EC
 00675000939

ER 20 410113010-55 1:2 IC 80 bar
 00675000939

ER 16 410410004-55 1:3 EC
 00675000937

ER 16 410410005-55 1:3 IC 80 bar
 00675000937

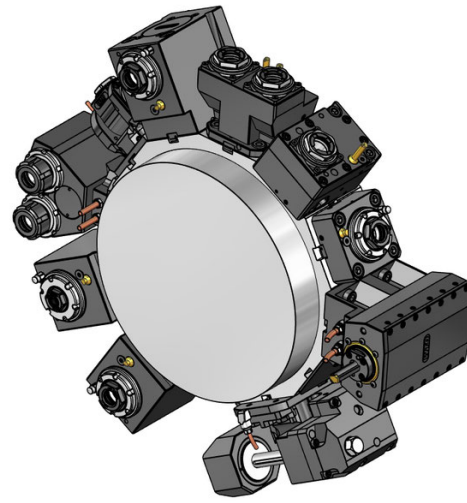
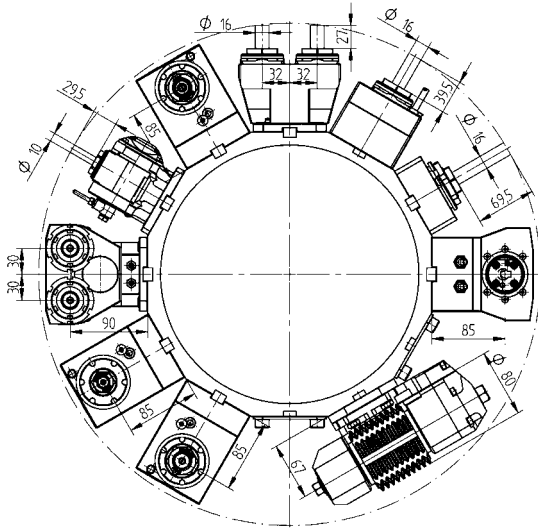

Driven Toolholders - Enhanced Program



Right angle drill/milling unit, LF=85

ER 32	410520030-55	1:1	EC
	0067725000		
ER 32	410520031-55	1:1	IC 80 bar
	0067725000		
ER-20 QF	420520014-55	1:2	EC
	0067720001		
ER-20 QF	420520015-55	1:2	IC 80 bar
	0067720001		
ER 16	410810020-55	1:3	EC
	00675000841		
ER 16	410810021-55	1:3	IC 80 bar
	00675000841		
ER-25 QF	420525032-55	2:1	EC
	0067725000		
ER-25 QF	420525033-55	2:1	IC 80 bar
	0067725000		



Right angle milling unit with combination mill arbor DIN 6358, LF=85

Ø 22	410622011-55	1:1	EC
	00675000483		
Ø 3/4"	410619006-55	1:1	EC
	00675000483		

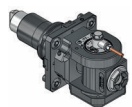

Adjustable angle drill/milling unit

ER 16	411010005-55	1:1	EC
	00675000902		
ER 16	411010006-55	1:1	IC 80 bar
	00675000902		
ER 11	411007007-55	1:2	EC
	00675000914		
ER 11	411007008-55	1:2	IC 80 bar
	00675000914		

Driven Toolholders - Enhanced Program



Gear hobbing unit

Type 16-1	411500002-55	1:1	EC
Type 16-1	411500001-55	2:1	EC
	00675000927		
	160016161 Ø 16		
	160022161 Ø 22		
	160027161 Ø 27		
	160015161 Ø 5/8"		
	160019161 Ø 3/4"		
	160025161 Ø 1"		
	160031161 Ø 1 1/4"		
	110587		

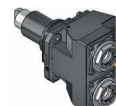

Straight drill/milling unit, double, Y axis

ER 25	413002004-55	1:1	EC
	00675000970		
ER 25	413002003-55	1:1	IC 80 bar
	00675000970		



2-spindle - Right angle drill/milling unit, Y axis

ER 25	413502007-55	1:1	EC
	00675000915		
ER 25	413502008-55	1:1	IC 80 bar
	00675000915		

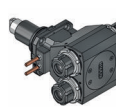

2-spindle - Right angle drill/milling unit, both sides, Y axis

ER 25	413502006-55	1:1	EC
	00675000915		

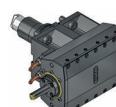

Broaching unit for ID and OD

TN765050	414532000-55	1:1	EC
-----------------	--------------	-----	----

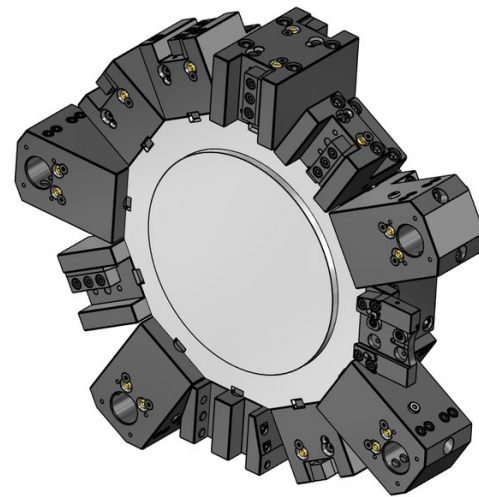
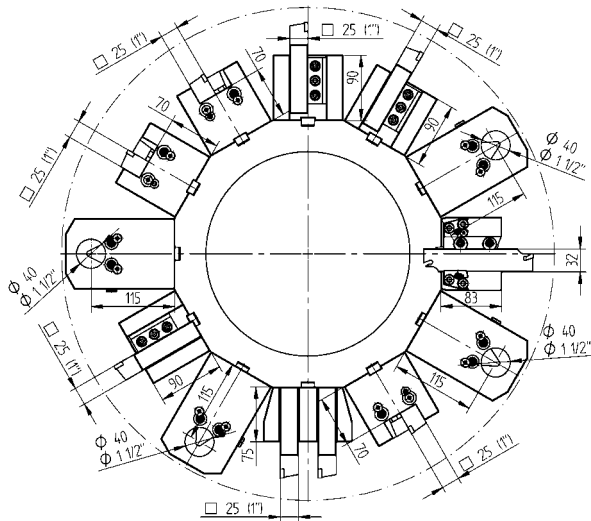

Static Toolholders - Standard Program

Static Toolholders - Standard Program

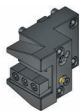

OD cutting holder

25 48-92428
1" 48-92466



OD cutting holder, HP-IC

25 48-92428-HP IC 80 bar
1" 48-92466-HP IC 80 bar

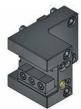

OD cutting holder, long

25 48-86711
1" 48-86712



OD cutting holder, both sides

25 48-92438
1" 48-92472



OD cutting holder, both sides, HP-IC

25 48-92438-HP IC 80 bar
1" 48-92472-HP IC 80 bar



OD cutting holder, both sides, long

25 48-84523
1" 48-86718



Face cutting holder

25 48-86719
1" 48-86720



Face cutting holder, HP-IC

25 48-109249-HP IC 80 bar
1" 48-109250-HP IC 80 bar



Combination toolholder, LF=115

Ø 40 48-86623 IC 80 bar
241140020 ER32
241140026 ER40
Ø 1 1/2" 48-86624 IC 80 bar
2411150020 ER32



Cover plate

48-87089

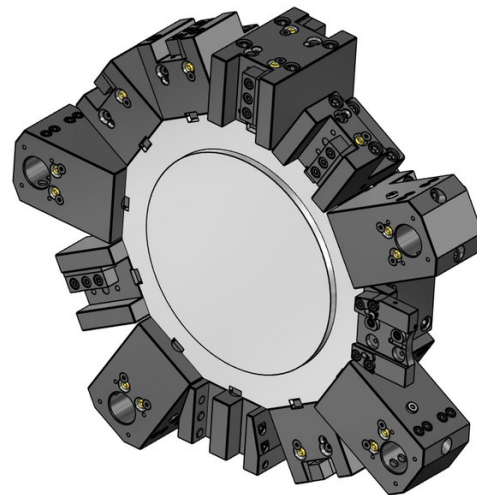
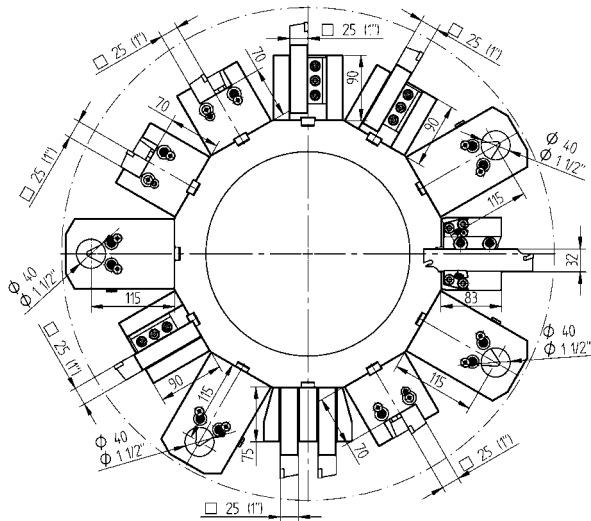

Static Toolholders - Enhanced Program



OD cutting holder, double, Y axis
 25(1") 48-86103



OD cutting holder, both sides, double, Y axis
 25(1") 48-86150



Cut-off holder, adjustable
 SH 32 48-99060



Cut-off holder, adjustable, long
 SH 32 48-100084



Cut-off holder, adjustable, HP-IC
 SH 32 48-102256R IC 80 bar
 SH 32 48-102256L IC 80 bar



Cut-off holder, adjustable, long, HP-IC
 SH 32 48-100082R IC 80 bar
 SH 32 48-100082L IC 80 bar

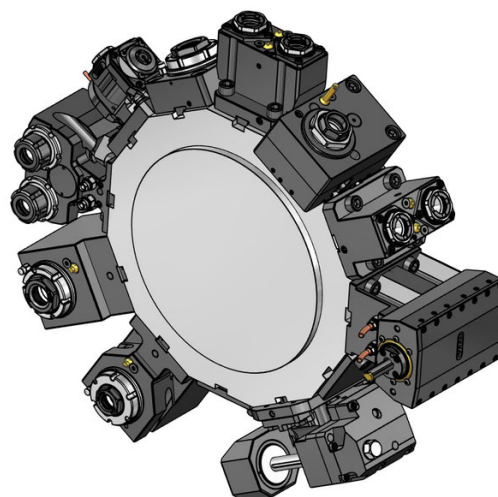
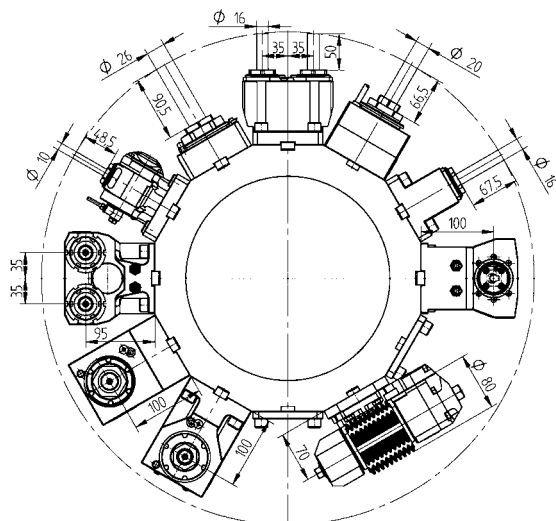

Driven Toolholders - QuickFlex®

- 

Straight drill/milling unit
ER-32 QF 420132015-65 1:1 EC
 0067732000

ER-32 QF 420132016-65 1:1 IC 80 bar
 0067732000
- 



Right angle drill/milling unit, LF=100
ER-32 QF 420532018-65 1:1 EC
 0067732000

ER-32 QF 420532019-65 1:1 IC 80 bar
 0067732000
- 



Right angle drill/milling unit, both sides, LF=100
ER-32 QF 420532020-65 1:1 EC
 0067732000

Driven Toolholders - Enhanced Program

- 

Straight drill/milling unit
ER 40 410126001-65 1:1 EC
 00675000079
- 



Straight milling unit with combination mill arbor DIN 6358
Ø 22 410222002-65 1:1 EC
 00675000483

Ø 1" 410225002-65 1:1 EC
 00675000483
- 

Straight offset drill/milling unit
ER-32 QF 420132037-65 1:1 EC
 0067732000

ER-32 QF 420132038-65 1:1 IC 80 bar
 0067732000

ER-25 QF 420125010-65 1:2 EC
 0067725001

ER-25 QF 420125011-65 1:2 IC 80 bar
 0067725001
- 

Right angle drill/milling unit, LF=100
ER 40 410526007-65 1:1 EC
 00675000079

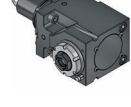
ER 40 410526008-65 1:1 IC 80 bar
 00675000079
- 

Right angle drill/milling unit, LF=100
ER-25 QF 420525012-65 1:2 EC
 0067725001

ER-25 QF 420525013-65 1:2 IC 80 bar
 0067725001

ER-32 QF 420532029-65 2:1 EC
 0067732000

ER-32 QF 420532030-65 2:1 IC 80 bar
 0067732000

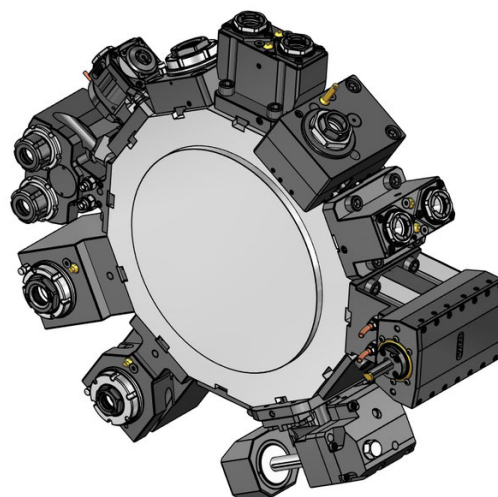
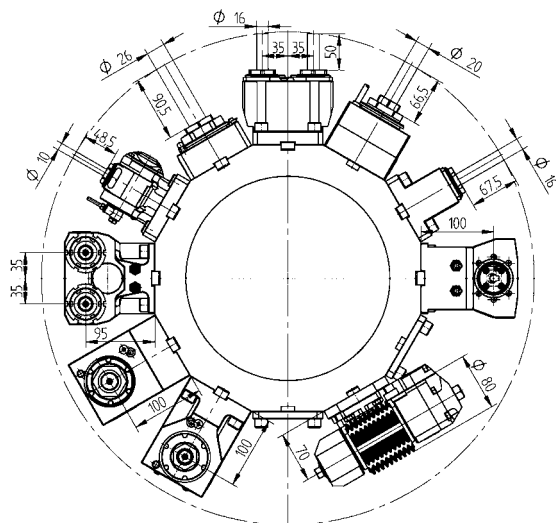

Driven Toolholders - Enhanced Program

Right angle milling unit with combination mill arbor DIN 6358, LF=100



Ø 22	410622002-65	1:1	EC
	00675000483		
Ø 1"	410625002-65	1:1	EC
	00675000483		

Adjustable angle drill/milling unit



ER 16	411010002-65	1:1	EC
	00675000902		
ER 16	411010003-65	1:1	IC 80 bar
	00675000902		
ER 11	411007002-65	1:2	EC
	00675000914		
ER 11	411007003-65	1:2	IC 80 bar
	00675000914		

Gear hobbing unit



Type 16-1	411500003-65	1:1	EC
Type 16-1	411500002-65	2:1	EC
	00675000927		
	160016161 Ø 16		
	160022161 Ø 22		
	160027161 Ø 27		
	160015161 Ø 5/8"		
	160019161 Ø 3/4"		
	160025161 Ø 1"		
	160031161 Ø 1 1/4"		
	110587		

Straight drill/milling unit, both sides



ER 25	413002001-65	1:1	EC
	00675000907		

Driven Toolholders - Enhanced Program

Straight drill/milling unit, double, Y axis



ER 25	413002004-65	1:1	EC
	00675000907		

2-spindle - Right angle drill/milling unit, Y axis

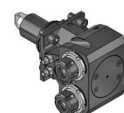

ER 25	413502006-65	1:1	EC
	00675000915		
ER 25	413502007-65	1:1	IC 80 bar
	00675000915		

2-spindle - Right angle drill/milling unit, both sides, Y axis

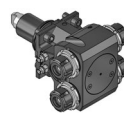

ER 25	413502008-65	1:1	EC
	00675000915		

Broaching unit for ID and OD

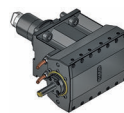

TN765050	414532000-65	1:1	EC
-----------------	--------------	-----	----

Standard reduction sleeves - cylindrical



Reduction sleeve Ø 20

240020006	ø 6
240020008	ø 8
240020010	ø 10
240020012	ø 12
240020014	ø 14
240020016	ø 16



Reduction sleeve Ø 25

240025006	ø 6
240025008	ø 8
240025010	ø 10
240025012	ø 12
240025014	ø 14
240025016	ø 16
240025020	ø 20



Reduction sleeve Ø 32

240032006	ø 6
240032008	ø 8
240032010	ø 10
240032012	ø 12
240032014	ø 14
240032016	ø 16
240032018	ø 18
240032020	ø 20
240032025	ø 25



Reduction sleeve Ø 40

240040006	ø 6
240040008	ø 8
240040010	ø 10
240040012	ø 12
240040014	ø 14
240040016	ø 16
240040020	ø 20
240040025	ø 25
240040032	ø 32



Reduction sleeve Ø 50

240050010	ø 10
240050012	ø 12
240050016	ø 16
240050020	ø 20
240050025	ø 25
240050025	ø 25
240050032	ø 32
240050040	ø 40

Standard reduction sleeves - cylindrical



Reduction sleeve Ø 60

240060012	ø 12
240060016	ø 16
240060020	ø 20
240060025	ø 25
240060032	ø 32
240060040	ø 40
240060050	ø 50



Reduction sleeve Ø 80

240080020	ø 20
240080025	ø 25
240080032	ø 32
240080040	ø 40
240080050	ø 50
240080060	ø 60



Reduction sleeve Ø 1"

2400100025	ø 1/4"
2400100031	ø 5/16"
2400100038	ø 3/8"
2400100050	ø 1/2"
2400100063	ø 5/8"
2400100075	ø 3/4"



Reduction sleeve Ø 1 1/4"

2400125038	ø 3/8"
2400125050	ø 1/2"
2400125063	ø 5/8"
2400125075	ø 3/4"
2400125088	ø 7/8"
2400125100	ø 1"



Reduction sleeve Ø 1 1/2"

2400150038	ø 3/8"
2400150050	ø 1/2"
2400150063	ø 5/8"
2400150075	ø 3/4"
2400150088	ø 7/8"
2400150100	ø 1"
2400150125	ø 1 1/4"

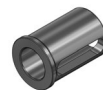

Reduction sleeve Ø 2"

2400200050	ø 1/2"
2400200063	ø 5/8"
2400200088	ø 7/8"
2400200100	ø 1"
2400200125	ø 1 1/4"
2400200150	ø 1 1/2"
2400200175	ø 1 3/4"

Standard reduction sleeves - cylindrical, with slot



Reduction sleeve Ø 40

240140010	Ø 10
240140012	Ø 12
240140015	Ø 15
240140016	Ø 16
240140020	Ø 20
240140025	Ø 25
240140032	Ø 32

Standard reduction sleeves - morse taper



Reduction sleeve Ø 32

240532001	MT 1
240532002	MT 2
240532003	MT 3



Reduction sleeve Ø 40

240540001	MT 1
240540002	MT 2
240540003	MT 3
240540004	MT 4



Reduction sleeve Ø 50

240550002	MT 2
240550003	MT 3
240550004	MT 4

Collets DIN 6499B (ER/ESX)



ER 11	mm	inch
190011000	∅ 7-0.5	∅ 0.276-0.020
190011010	∅ 1-0.5	∅ 0.039-0.020
190011015	∅ 1.5-1	∅ 0.059-0.039
190011020	∅ 2-1.5	∅ 0.079-0.059
190011025	∅ 2.5-2	∅ 0.098-0.079
190011030	∅ 3-2.5	∅ 0.118-0.098
190011035	∅ 3.5-3	∅ 0.138-0.118
190011040	∅ 4-3.5	∅ 0.158-0.138
190011045	∅ 4.5-4	∅ 0.177-0.158
190011050	∅ 5-4.5	∅ 0.197-0.177
190011055	∅ 5.5-5	∅ 0.217-0.197
190011060	∅ 6-5.5	∅ 0.236-0.217
190011065	∅ 6.5-6	∅ 0.256-0.236
190011070	∅ 7-6.5	∅ 0.276-0.256



ER 16	mm	inch
190016000	∅ 10-0.5	∅ 0.394-0.020
190016010	∅ 1-0.5	∅ 0.039-0.020
190016020	∅ 2-1	∅ 0.079-0.039
190016030	∅ 3-2	∅ 0.118-0.079
190016040	∅ 4-3	∅ 0.158-0.118
190016050	∅ 5-4	∅ 0.197-0.158
190016060	∅ 6-5	∅ 0.236-0.197
190016070	∅ 7-6	∅ 0.276-0.236
190016080	∅ 8-7	∅ 0.315-0.276
190016090	∅ 9-8	∅ 0.354-0.315
190016100	∅ 10-9	∅ 0.394-0.354



ER 20	mm	inch
190020000	∅ 13-1	∅ 0.512-0.039
190020010	∅ 1-0.5	∅ 0.039-0.020
190020020	∅ 2-1	∅ 0.079-0.039
190020030	∅ 3-2	∅ 0.118-0.079
190020040	∅ 4-3	∅ 0.157-0.118
190020050	∅ 5-4	∅ 0.197-0.157
190020060	∅ 6-5	∅ 0.236-0.197
190020070	∅ 7-6	∅ 0.276-0.236
190020080	∅ 8-7	∅ 0.315-0.276
190020090	∅ 9-8	∅ 0.354-0.315
190020100	∅ 10-9	∅ 0.394-0.354
190020110	∅ 11-10	∅ 0.433-0.394
190020120	∅ 12-11	∅ 0.472-0.433
190020130	∅ 13-12	∅ 0.512-0.472

Collets DIN 6499B (ER/ESX)



ER 25	mm	inch
190025000	∅ 16-1	∅ 0.630-0.039
190025020	∅ 2-1	∅ 0.079-0.039
190025030	∅ 3-2	∅ 0.118-0.079
190025040	∅ 4-3	∅ 0.157-0.118
190025050	∅ 5-4	∅ 0.197-0.157
190025060	∅ 6-5	∅ 0.236-0.197
190025070	∅ 7-6	∅ 0.276-0.236
190025080	∅ 8-7	∅ 0.315-0.276
190025090	∅ 9-8	∅ 0.354-0.315
190025100	∅ 10-9	∅ 0.394-0.354
190025110	∅ 11-10	∅ 0.433-0.394
190025120	∅ 12-11	∅ 0.472-0.433
190025130	∅ 13-12	∅ 0.512-0.472
190025140	∅ 14-13	∅ 0.551-0.512
190025150	∅ 15-14	∅ 0.591-0.551
190025160	∅ 16-15	∅ 0.630-0.591



ER 32	mm	inch
190032000	∅ 20-2	∅ 0.787-0.079
190032030	∅ 3-2	∅ 0.118-0.079
190032040	∅ 4-3	∅ 0.157-0.118
190032050	∅ 5-4	∅ 0.197-0.157
190032060	∅ 6-5	∅ 0.236-0.197
190032070	∅ 7-6	∅ 0.276-0.236
190032080	∅ 8-7	∅ 0.315-0.276
190032090	∅ 9-8	∅ 0.354-0.315
190032100	∅ 10-9	∅ 0.394-0.354
190032110	∅ 11-10	∅ 0.433-0.394
190032120	∅ 12-11	∅ 0.472-0.433
190032130	∅ 13-12	∅ 0.512-0.472
190032140	∅ 14-13	∅ 0.551-0.512
190032150	∅ 15-14	∅ 0.591-0.551
190032160	∅ 16-15	∅ 0.630-0.591
190032170	∅ 17-16	∅ 0.669-0.630
190032180	∅ 18-17	∅ 0.709-0.669
190032190	∅ 19-18	∅ 0.748-0.709
190032200	∅ 20-19	∅ 0.787-0.748

Collets DIN 6499B (ER/ESX)



ER 40	mm	inch
190040000	∅ 26-3	∅ 1.024-0.118
190040040	∅ 4-3	∅ 0.157-0.118
190040050	∅ 5-4	∅ 0.197-0.157
190040060	∅ 6-5	∅ 0.236-0.197
190040070	∅ 7-6	∅ 0.276-0.236
190040080	∅ 8-7	∅ 0.315-0.276
190040090	∅ 9-8	∅ 0.354-0.315
190040100	∅ 10-9	∅ 0.394-0.354
190040110	∅ 11-10	∅ 0.433-0.394
190040120	∅ 12-11	∅ 0.472-0.433
190040130	∅ 13-12	∅ 0.512-0.472
190040140	∅ 14-13	∅ 0.551-0.512
190040150	∅ 15-14	∅ 0.591-0.551
190040160	∅ 16-15	∅ 0.630-0.591
190040170	∅ 17-16	∅ 0.669-0.630
190040180	∅ 18-17	∅ 0.709-0.669
190040190	∅ 19-18	∅ 0.748-0.709
190040200	∅ 20-19	∅ 0.787-0.748
190040210	∅ 21-20	∅ 0.827-0.787
190040220	∅ 22-21	∅ 0.866-0.827
190040230	∅ 23-22	∅ 0.906-0.866
190040240	∅ 24-23	∅ 0.945-0.906
190040250	∅ 25-24	∅ 0.984-0.945
190040260	∅ 26-25	∅ 1.024-0.984



ER 50	mm	inch
190050000	∅ 34-10	∅ 1.339-0.394
190050060	∅ 6-4	∅ 0.236-0.157
190050080	∅ 8-6	∅ 0.315-0.236
190050100	∅ 10-8	∅ 0.394-0.315
190050120	∅ 12-10	∅ 0.472-0.394
190050140	∅ 14-12	∅ 0.551-0.472
190050160	∅ 16-14	∅ 0.630-0.551
190050180	∅ 18-16	∅ 0.709-0.630
190050200	∅ 20-18	∅ 0.787-0.709
190050220	∅ 22-20	∅ 0.866-0.787
190050240	∅ 24-22	∅ 0.945-0.866
190050260	∅ 26-24	∅ 1.024-0.945
190050280	∅ 28-26	∅ 1.102-1.024
190050300	∅ 30-28	∅ 1.181-1.102
190050320	∅ 32-30	∅ 1.260-1.181
190050340	∅ 34-32	∅ 1.339-1.260

Collets DIN 6499D (ER/ESX) - sealed, for IC



ER 11	mm	inch
191011030	∅ 3	
191011040	∅ 4	
191011050	∅ 5	
191011060	∅ 6	
191111013-in		∅ 0.125
191111019-in		∅ 0.188
191111025-in		∅ 0.25



ER 16	mm	inch
191016000	∅ 3-10	
191016030	∅ 3	
191016040	∅ 4	
191016050	∅ 5	
191016060	∅ 6	
191016070	∅ 7	
191016080	∅ 8	
191016090	∅ 9	
191016100	∅ 10	
191116001		∅ 0.125-0.375
191116013-in		∅ 0.125
191116019-in		∅ 0.188
191116025-in		∅ 0.25
191116031-in		∅ 0.313
191116038-in		∅ 0.375



ER 20	mm	inch
191020000	∅ 3-12	
191020030	∅ 3	
191020040	∅ 4	
191020050	∅ 5	
191020060	∅ 6	
191020070	∅ 7	
191020080	∅ 8	
191020090	∅ 9	
191020100	∅ 10	
191020110	∅ 11	
191020120	∅ 12	
191120001		∅ 0.125-0.5
191120013-in		∅ 0.125
191120019-in		∅ 0.188
191120025-in		∅ 0.25
191120031-in		∅ 0.313
191120038-in		∅ 0.375
191120044-in		∅ 0.438
191120050-in		∅ 0.5

Collets DIN 6499D (ER/ESX) - sealed, for IC

Collets DIN 6499D (ER/ESX) - sealed, for IC



ER 25	mm	inch
191025000	ø 4-16	
191025030	ø 3	
191025040	ø 4	
191025050	ø 5	
191025060	ø 6	
191025070	ø 7	
191025080	ø 8	
191025090	ø 9	
191025100	ø 10	
191025110	ø 11	
191025120	ø 12	
191025130	ø 13	
191025140	ø 14	
191025150	ø 15	
191025160	ø 16	
191125001		ø 0.25-0.625
191125025-in		ø 0.25
191125031-in		ø 0.313
191125038-in		ø 0.375
191125044-in		ø 0.438
191125050-in		ø 0.5
191125056-in		ø 0.563
191125063-in		ø 0.625



ER 40	mm	inch
191040060	ø 6	
191040080	ø 8	
191040100	ø 10	
191040120	ø 12	
191040140	ø 14	
191040160	ø 16	
191040180	ø 18	
191040200	ø 20	
191040220	ø 22	
191040250	ø 25	
191140025-in		ø 0.25
191140031-in		ø 0.313
191140038-in		ø 0.375
191140044-in		ø 0.438
191140050-in		ø 0.5
191140056-in		ø 0.563
191140063-in		ø 0.625
191140069-in		ø 0.688
191140075-in		ø 0.75
191140088-in		ø 0.875
191140100-in		ø 1



ER 32	mm	inch
191032000	ø 4-20	
191032030	ø 3	
191032040	ø 4	
191032050	ø 5	
191032060	ø 6	
191032070	ø 7	
191032080	ø 8	
191032090	ø 9	
191032100	ø 10	
191032110	ø 11	
191032120	ø 12	
191032130	ø 13	
191032140	ø 14	
191032150	ø 15	
191032160	ø 16	
191032170	ø 17	
191032180	ø 18	
191032190	ø 19	
191032200	ø 20	
191132001		ø 0.25-0.75
191132025-in		ø 0.25
191132031-in		ø 0.313
191132038-in		ø 0.375
191132044-in		ø 0.438
191132050-in		ø 0.5
191132056-in		ø 0.563
191132063-in		ø 0.625
191132069-in		ø 0.688
191132075-in		ø 0.75

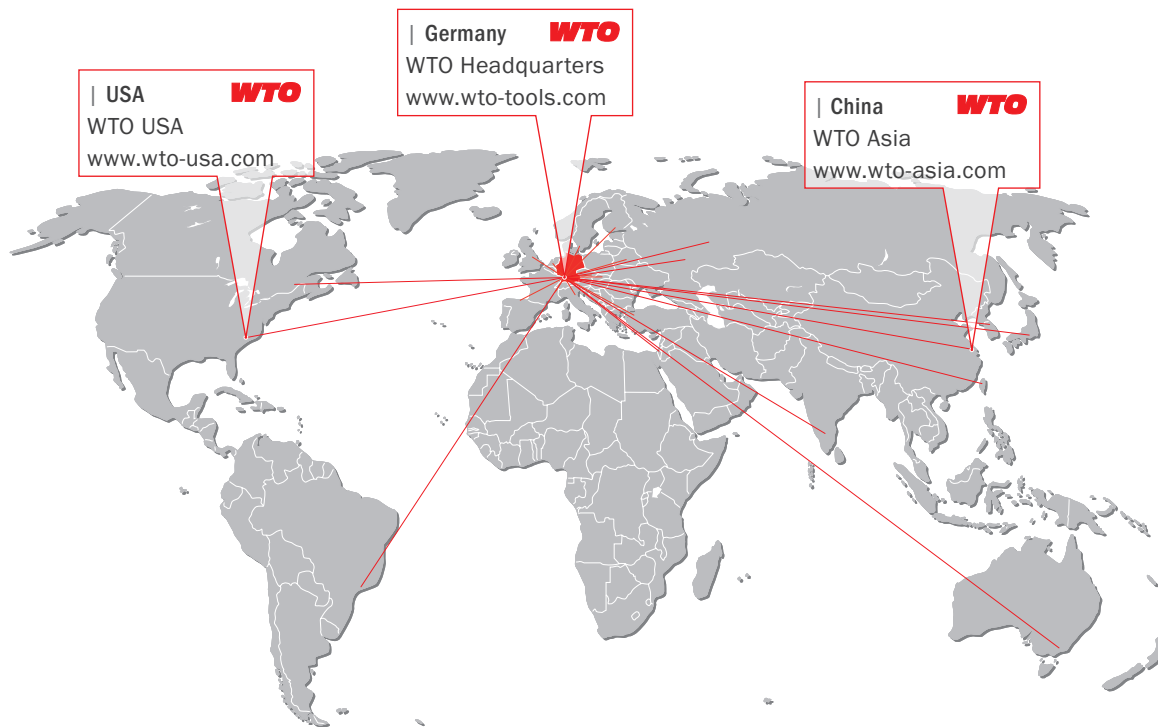

| USA **WTO**
WTO USA
www.wto-usa.com

| Germany **WTO**
WTO Headquarters
www.wto-tools.com

| China **WTO**
WTO Asia
www.wto-asia.com

WTO Werkzeug-
Einrichtungen GmbH
Auf der oberen Au 45
77797 Ohlsbach
Germany

WTO Inc.
13900-F South Lakes Dr.
Charlotte, NC 28273
USA

WTO Asia
Room 109-110, Building 2
No. 228 Banting Road
Jiuting Town,
Songjiang District
201615 Shanghai
China

Our distribution partners. Competence right there.

| Australia
Dimac Tooling Ltd.
sales@dimac.com.au

| Finland
Suomen Terästuonti Oy
myynti@stt.as

| Korea
WTO Office Korea
is.chon@wto-korea.com

| Slovakia
ALBA precision s.r.o.
albaprecision@albaprecision.sk

| Belarus
LLC "PMI Engineering"
tool@pmi.by

| France
Philippe Tagliafero
pta@wto.de

| Mexico
Workholding Engineering De México
info@wem.com.mx

| Spain
ITALMATIC, S.A.
italmatic@italmatic.es

| Brazil
TF2
tfdois@tfdois.com.br

| Great Britain
Cutwel Ltd.
sales@cutwel.net

| Netherlands
Toologic BeNeLux B.V.
info@toologic-benelux.nl

| Sweden
Bonthron & Ewing AB
info@bonthron-ewing.se

| Canada
Mittmann Industrial Inc.
info@mittmann.com

| India
Ulhas Patil
u.patil@wto-asia.com

| Norway
Helge Karlsen Verktøy og Maskin AS
hkvm@hkvm.no

| Switzerland
Utilis AG
info@utilis.com

| China
Shanghai Gangde
wtocando@yahoo.com

| Israel
E.Y.A.R. Ltd.
boris@eyar.co.il

| Poland
ARCO Andrzej Rudenko
info@arcotools.pl

| Taiwan
Kaiko Co., Ltd.
info@kaiko.com.tw

| Czech Republic
ALBA precision, spol. s.r.o.
info@albaprecision.cz

| Italy
Prymark srl
commerciale@prymark.it

| Romania
SC Elif Trading SRL
bulent.ozkan@eliftrading.com

| Turkey
MYK CNC MAKINA SAN. VE
huseyin.tatidil@mykcnc.com.tr

| Denmark
Tool-part
cj@tool-part.dk

| Japan
NK Works Co. Ltd.
k_samba@nk-works.co.jp

| Russia
WTO Office Russia
office@wto-russia.com

| Ukraine
„LLC“ SPA Stankopromimport
info@phoenix-ua.com