

LANGDREHTECHNIK

TECHNOLOGY FOR SWISS
TYPE MACHINES

2020/2021



**DAS WERKZEUG
HORN TOOLS**

Der neue Katalog Langdrehtechnik von HORN – Abgestimmt auf Ihre Bedürfnisse

In diesem Katalog finden Sie eine Auswahl an HORN-Produkten, die speziell für den Einsatz auf Langdrehmaschinen abgestimmt sind.

Zu den folgenden Themen haben wir die passenden Werkzeuge für Ihren Anwendungsfall zusammengestellt:

- Innenbearbeitung
- Ein- und Abstechen
- Außenbearbeitung
- Gewindewirbeln
- Lineareinheiten

Bei der Wahl der individuellen Schnittparameter unterstützen Sie unsere Tabellen mit praxiserprobten Erfahrungswerten. Nutzen Sie das Fachwissen unserer Innen- und Außendienstmitarbeiter. Denn wir kennen den Markt und haben für Ihre Aufgaben und Herausforderungen die passenden Lösungen.



Lothar Horn
Geschäftsführer
Paul Horn GmbH



Markus Horn
Geschäftsführer
Paul Horn GmbH



Matthias Rommel
Geschäftsführer
Paul Horn GmbH

The new catalogue Technology for Swiss Type Machines from HORN - Designed for your application

In this catalogue you will find a selection of HORN products which are specially designed for use on Swiss Type Machines.

For the following issues we have selected the right tools for your application:

- Internal Machining
- Grooving and Parting Off
- External Machining
- Thread Whirling
- Linear Units

To assist you when choosing cutting parameters, our tables provide proven empirical values. Take advantage of the expertise of our office staff and sales engineers, because we know the market well and have the right solutions for your applications and challenges.





Lothar Horn
CEO
Paul Horn GmbH



Markus Horn
CEO
Paul Horn GmbH



Matthias Rommel
CEO
Paul Horn GmbH

A	Supermini® 105		
A	Supermini® 105	zur Feinstbearbeitung for ultrafine machining	
A	Supermini® 109		
B	System Mini 106, 107, 108		
C	System 100 / 101		
D	System 262		
E	System 264		
F	System 274		
F	System 274 μ-Finish		
G	System 312		
H	System 32T		
I	Technische Hinweise	Technical Information	
J	Graf Schnellwechselsystem Lineareinheit	Graf Quick change system Linear unit	

A**A****A****B****C****D****E****F****F****G****H****I****J**



- K** **W+F Lineareinheit für Langdreher**
W+F Linear unit for Swiss Type Machines

- L** **Gewindewirbeln**
Thread Whirling

System	105	105 	109	106	107	108	100	101
Innenbearbeitung / Internal Grooving								
Bohrungs-Ø Bore Ø	1,0 - 6,8	0,2 - 5,0	≥ 6,0	≥ 6,0	≥ 7,0	≥ 8,0		
Stechbreite Width of groove	0,5 - 2,0		1,0 - 2,0	0,7 - 1,5	1,0 - 2,0	0,7 - 2,0		
Stechtiefe Depth of groove	2,5		2,5	0,8	2,0	1,0		
Einstechen und Ausdrehen Grooving and Boring	•	•	•	•	•	•		
Gewindedrehen Threading	•				•	•		
Fasen Chamfering	•		•	•	•	•		
Axialeinstechen Facegrooving	•		•					
Feinstbearbeitung Ultrafine machining		•						
Außenbearbeitung / External Grooving								
Stechbreite Width of groove							2,0 - 3,0	1,2 - 1,6
Stechtiefe Depth of groove							≤ 21	≤ 13
Einstechen Grooving							•	•
Längsdrehen Turning							•	
Abstechen Parting off							•	•
Gewinde Thread								
für kurvengesteuerte Maschinen for cam-controlled machines								
µ-Finish								
Kapitel Chapter	A	A	A	B	B	B	C	C

Abmessung in mm
Dimensions in mm

System	262	264	274	274 μ	312	32T
Innenbearbeitung / Internal Grooving						
Bohrungs-Ø Bore Ø						
Stechbreite Width of groove						
Stechtiefe Depth of groove						
Einstechen und Ausdrehen Grooving and Boring						
Gewindedrehen Threading						
Fasen Chamfering						
Axialeinstechen Facegrooving						
Feinstbearbeitung Ultrafine machining						
Außenbearbeitung / External Grooving						
Stechbreite Width of groove	0,5-2,0	1,5-3,0	0,5-7	0,5-4,0	0,5-6,3	2,0-3,0
Stechtiefe Depth of groove	≤ 5	≤ 16	≤ 6	≤ 6	≤ 8	≤ 3,5
Einstechen Grooving	•	•	•	•	•	•
Längsdrehen Turning	•	•	•	•	•	•
Abstechen Parting off	•	•	•	•	•	•
Gewinde Thread		•	•			•
für kurvengesteuerte Maschinen for cam-controlled machines	•					
μ-Finish				•		
Kapitel Chapter	D	E	F	F	G	H

Abmessung in mm
Dimensions in mm



Werkzeuge für die Mikrobearbeitung

Bei Bearbeitung von Bauteilen in Bereichen ab \varnothing 0,2 mm, mit Spantiefen die nicht selten bei 0,01 mm liegen, werden extrem hohe Forderungen an das Werkzeug, das Werkzeugsystem und vor allem an die Schneidenausführung gestellt.

Extrem scharf, ausbruchfrei und mit sehr feinen Oberflächenqualitäten müssen die Werkzeugschneiden ausgeführt sein um eine präzise Spanabhebung bei kleinsten Spantiefen zu garantieren.

Die zur Mikrobearbeitung eingesetzten Maschinen bieten in der Regel sehr beengte Platzverhältnisse für die Klemmhalter, so dass auch hier speziell abgestimmte Werkzeughalter zum Einsatz kommen müssen. Maximale Performance der Werkzeugschneiden garantiert die Ausführung der Klemmhalter mit innerer Kühlmittelzufuhr.

Alle Werkzeuge die mit  gekennzeichnet sind, haben außerdem eine scharfe Schneidkante und sind feinstgeschliffen.

Tools for the micro machining

When machining components in areas starting from \varnothing 0.2 mm, with cutting depths that often lie at 0.01 mm, extremely high demands are placed on the tool, the tool system and above all on the cutting edge design.

The tool cutting edges must be extremely sharp, free of chipping and with very fine surface qualities in order to guarantee precise chip removal with the smallest cutting depth.

The machines used for micro-machining generally offer very limited space for the toolholders, so that specially adapted toolholders must be used here as well. Maximum performance of the tool cutting edges is guaranteed by the design of the toolholders with internal coolant supply.

All tools marked with  also have a sharp cutting edge and are precision ground.

105



**Klemmhalter mit
Schneidplatten**

Stechbreite 0,5 - 2 mm

**Toolholder
with Inserts**

Width of groove 0,5 - 2 mm

Klemmhalter
Toolholder
B105/962/963

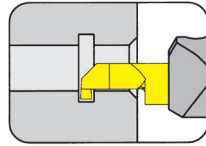

Seite/Page
A4-A7

Einstellbare Halter
Adjustable holder
BKT/N

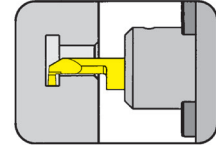

Seite/Page
A23-A29

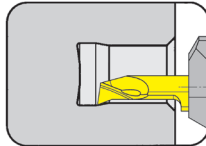

Seite/Page
A8

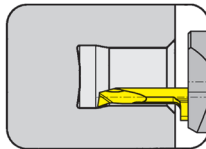

Seite/Page
A9-A10

Klemmhalter Graf
Toolholder Graf
962/963/963...IK



Seite/Page
A13-A16

Grundhalter Graf
Basic toolholder Graf
IR105/G



Seite/Page
A11, A19-A20

Einbauhalter Graf
Cartridge Graf
IR105



Seite/Page
A12

Grundhalter
Basic toolholder
HC105/760/BGT

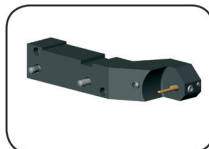

Seite/Page
A17-A18, A21

Schneidplatte
Insert
105

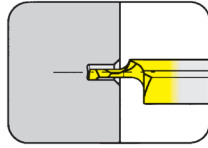

Seite/Page
A31-A35

Schneidplatte
Insert
105

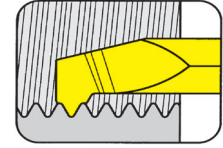

Seite/Page
A68-A69

Schneidplatte
Insert
105

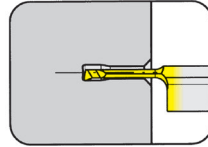

Seite/Page
A36-A37

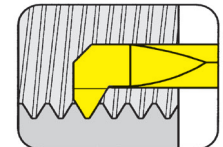

Seite/Page
A70

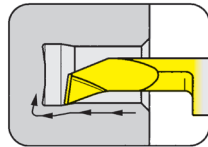

Seite/Page
A38-A51

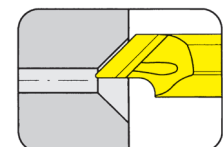

Seite/Page
A71

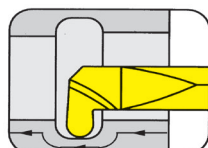

Seite/Page
A52-A54

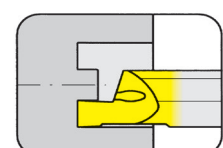

Seite/Page
A72-A75

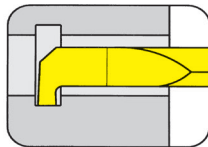

Seite/Page
A55-A60

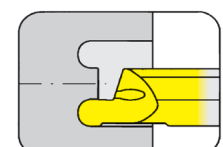

Seite/Page
A76

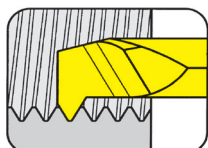

Seite/Page
A61-A65

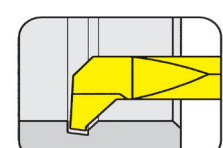

Seite/Page
A77

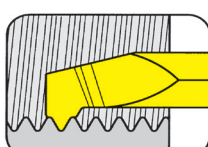

Seite/Page
A66

Platte
Insert
105

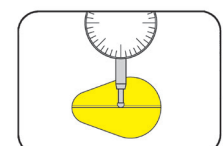

Seite/Page
A78

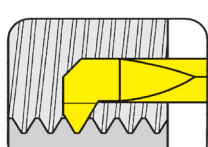

Seite/Page
A67

Klemmhalter

Toolholder

B105

mit innerer Kühlmittelzufuhr
with through coolant supply

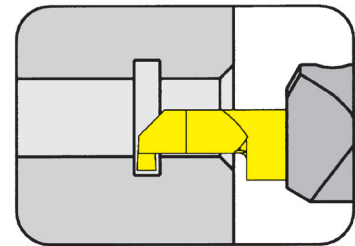

Bohrungs-Ø ab
Stechtiefe bis
Stechbreite bis

Bore Ø from
Depth of groove up to
Width of groove up to

0,2 mm
2,5 mm
2 mm

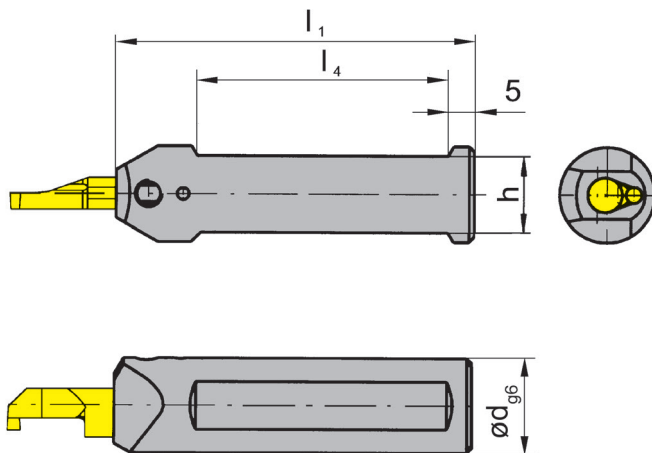

für Schneidplatte
for Insert

Typ 105
Type

Abbildung = rechtsschneidend
Picture = right hand cutting version

Bestellnummer Part number	d	l ₁	h	l ₄
B105.0010.01	10	75	9	50
B105.0012.01	12	75	11	50
B105.0016.01	16	75	14	50
B105.0020.01	20	90	18	55
B105.0022.01	22	90	20	55
B105.0025.01	25	100	23	55

Weitere Abmessungen auf Anfrage
Further sizes upon request

Abmessungen in mm
Dimensions in mm

Bestellhinweis:

Klemmhalter sind jeweils für rechte und linke Schneidplatten verwendbar.

Ordering note:

Toolholders can be used with right and left hand inserts.

Das Anzugsdrehmoment der Schrauben finden Sie in den Technischen Hinweisen.

For torque specification of the screw, please see Technical Instructions.

Ersatzteile

Spare Parts

Klemmhalter Toolholder	Spannschraube Clamping Screw	TORX PLUS®-Schlüssel TORX PLUS® Wrench
B105...	6.075T15P	T15PQ

Einstecken und Ausdrehen

Grooving and Boring



A

Klemmhalter

Toolholder

B105

mit innerer Kühlmittelzufuhr
with through coolant supply

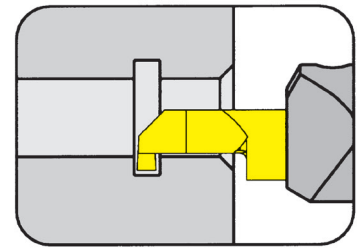

Bohrungs-Ø ab
Stechtiefe bis
Stechbreite bis

Bore Ø from
Depth of groove up to
Width of groove up to

0,2 mm
2,5 mm
2 mm

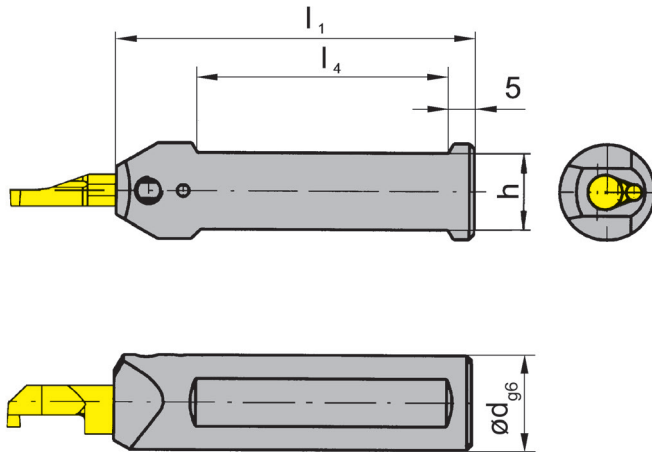

für Schneidplatte
for Insert

Typ 105
Type

Abbildung = rechtsschneidend
Picture = right hand cutting version

Bestellnummer Part number	d	l ₁	h	l ₄
B105.0012.M8.01	12	75	11	50
B105.0016.M8.01	16	75	14	50
B105.0020.M8.01	20	90	18	55
B105.0025.M8.01	25	100	23	55

Weitere Abmessungen auf Anfrage
Further sizes upon request

Abmessungen in mm
Dimensions in mm

Bestellhinweis:

Klemmhalter sind jeweils für rechte und linke Schneidplatten verwendbar.

Ordering note:

Toolholders can be used with right and left hand inserts.

Kühlmittelanschluss M8x1 (004.00.19) siehe Seite A30.

Der Kühlmittelanschluss gehört nicht zum Lieferumfang. Bitte separat bestellen!

Adapter of cooling M8x1 (004.00.19) see page A30.

Coolant supply must be ordered separately!

Das Anzugsdrehmoment der Schrauben finden Sie in den Technischen Hinweisen.

For torque specification of the screw, please see Technical Instructions.

Ersatzteile

Spare Parts

Klemmhalter Toolholder	Spannschraube Clamping Screw	TORX PLUS®-Schlüssel TORX PLUS® Wrench
B105...	6.075T15P	T15PQ

Klemmhalter

Toolholder

B105

mit innerer Kühlmittelzufuhr
with through coolant supply

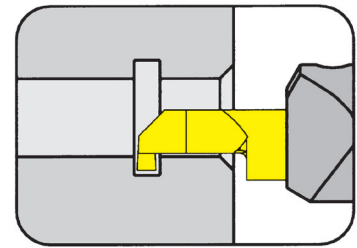

Bohrungs-Ø ab
Stechtiefe bis
Stechbreite bis

Bore Ø from
Depth of groove up to
Width of groove up to

0,2 mm
2,5 mm
2 mm

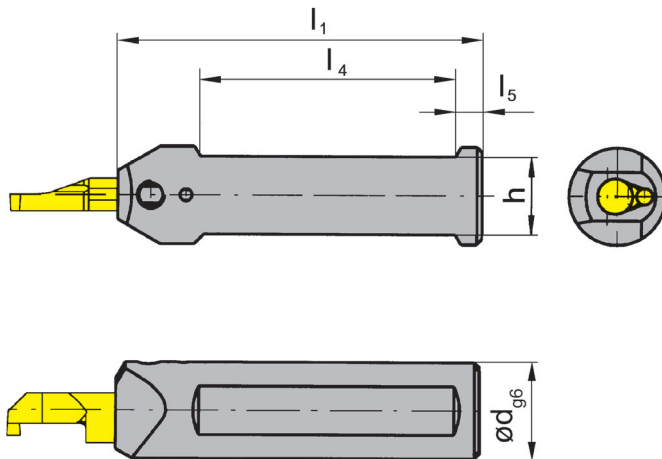

für Schneidplatte
for Insert

Typ 105
Type

Abbildung = rechtsschneidend
Picture = right hand cutting version

Bestellnummer Part number	d	l ₁	h	l ₄	l ₅
B105.0028.01	28,00	120,0	26,00	72	12
BU105.0750.5.01	3/4"	90,0	17,04	70	5
BU105.0750.5.3.01	3/4"	152,5	17,05	70	5
BU105.1000.5.01	1"	90,0	23,40	65	5
BU105.1000.5.3.01	1"	152,5	23,40	70	5

Weitere Abmessungen auf Anfrage
Further sizes upon request

Abmessungen in mm und Zoll
Dimensions in mm and inch

Kühlmittelanschluss M12x1,5

Der Kühlmittelanschluss gehört nicht zum Lieferumfang.
Adapter of cooling M12x1,5 Coolant supply is not included.

Bestellhinweis:

Klemmhalter sind jeweils für rechte und linke Schneidplatten verwendbar.

Ordering note:

Toolholders can be used with right and left hand inserts.

Das Anzugsdrehmoment der Schrauben finden Sie in den Technischen Hinweisen.
For torque specification of the screw, please see Technical Instructions.

Ersatzteile

Spare Parts

Klemmhalter Toolholder	Spannschraube Clamping Screw	TORX PLUS®-Schlüssel TORX PLUS® Wrench
B105...	6.075T15P	T15PQ

Einstechen und Ausdrehen

Grooving and Boring



A

Klemmhalter

Toolholder

B105

mit innerer Kühlmittelzufuhr
with through coolant supply

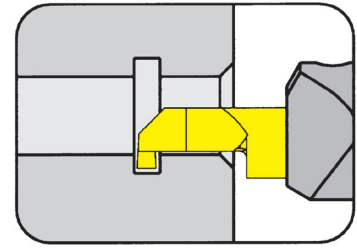

Bohrungs-Ø ab
Stechtiefe
Stechbreite bis

Bore Ø from
Depth of groove
Width of groove up to

0,2 mm
2,5 mm
2 mm

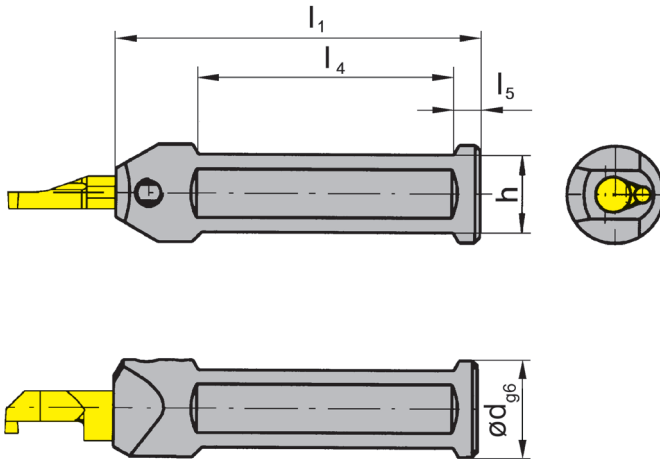

für Schneidplatte
for Insert

Typ 105
Type

Abbildung = rechtsschneidend
Picture = right hand cutting version

Bestellnummer Part number	d	l ₁	h	l ₄	l ₅
B105.0022.1.2.01	22	120	20	72	5

Weitere Abmessungen auf Anfrage
Further sizes upon request

Abmessungen in mm
Dimensions in mm

Bestellhinweis:

Klemmhalter sind jeweils für rechte und linke Schneidplatten verwendbar.

Ordering note:

Toolholders can be used with right and left hand inserts.

Das Anzugsdrehmoment der Schrauben finden Sie in den Technischen Hinweisen.

For torque specification of the screw, please see Technical Instructions.

Ersatzteile

Spare Parts

Klemmhalter Toolholder	Spannschraube Clamping Screw	TORX PLUS®-Schlüssel TORX PLUS® Wrench
B105.0022.1.2.01	6.075T15P	T15PQ

Klemmhalter

Toolholder

B105

mit innerer Kühlmittelzufuhr
with through coolant supply

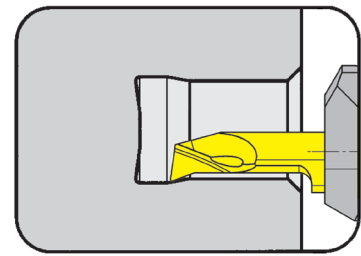

Bohrungs-Ø ab Stechtiefe	Bore Ø from Depth of groove	0,2 mm
Stechbreite	Width of groove	2,5 mm
		2 mm

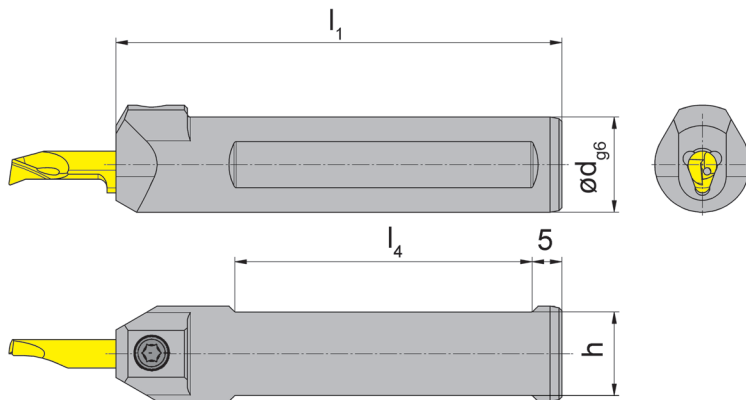

für Schneidplatte
for insert

Typ 105
Type

Abbildung = rechtsschneidend
Picture = right hand cutting version

mit zusätzlichen
Spülbohrungen
with additional through
coolant bores

Bestellnummer Part number	d	l ₁	h	l ₄
B105.0012.K.01	12	75	11	50
B105.0016.K.01	16	75	14	50
B105.0020.K.01	20	90	18	50
B105.0025.K.01	25	100	23	55
B105.0012.M8.K.01**	12	75	11	50
B105.0016.M8.K.01**	16	75	14	50
B105.0020.M8.K.01**	20	90	18	55

Weitere Abmessungen auf Anfrage
Further sizes upon request

Abmessungen in mm
Dimensions in mm

Bestellhinweis:

Klemmhalter sind jeweils für rechte und linke Schneidplatten verwendbar.

Ordering note:

Toolholders can be used with right and left hand inserts.

** Kühlmittelanschluss M8x1 (004.00.19) siehe Seite A30.

Der Kühlmittelanschluss gehört nicht zum Lieferumfang. Bitte separat bestellen!

** Adapter of cooling M8x1 (004.00.19) see page A30.

Coolant supply must be ordered separately!

Das Anzugsdrehmoment der Schrauben finden Sie in den Technischen Hinweisen.

For torque specification of the screw, please see Technical Instructions.

Ersatzteile

Spare Parts

Klemmhalter Toolholder	Spannschraube Clamping Screw	TORX PLUS®-Schlüssel TORX PLUS® Wrench
B105...	6.075T15P	T15PQ

Einstechen und Ausdrehen

Grooving and Boring



A

Klemmhalter

Toolholder

B105

mit innerer Kühlmittelzufuhr
with through coolant supply

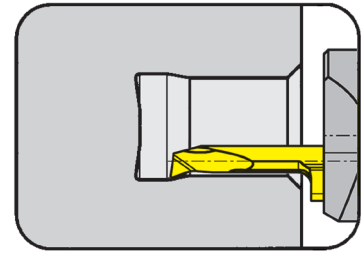

Bohrungs-Ø ab
Stechtiefe
Stechbreite bis

Bore Ø from
Depth of groove
Width of groove up to

0,2 mm
2,5 mm
2 mm

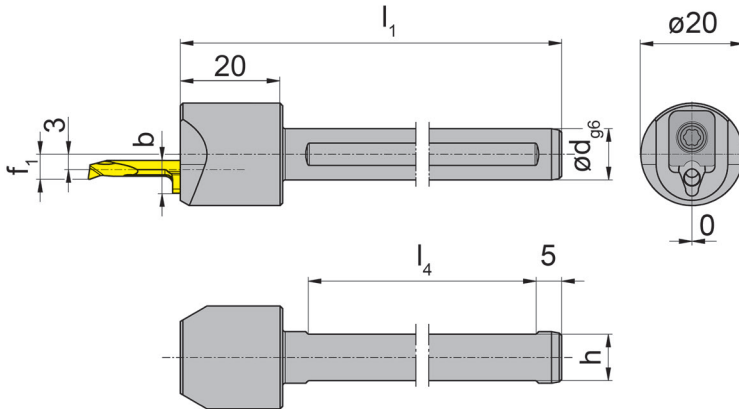

für Schneidplatte
for Insert

Typ 105
Type

Stirnseitige Klemmung!
Face clamped insert!

Abbildung = rechtsschneidend
Picture = right hand cutting version

Bestellnummer Part number	d	l ₁	h	l ₄	f ₁	b
B105.0010.S.03	10	80	9	50	4,3	5,9
B105.0012.S.03	12	80	11	50	4,3	5,9
B105.0016.S.03	16	80	14	50	4,3	5,9
B105.0020.S.03	20	90	18	55	4,3	5,9
B105.0022.S.03	22	90	20	55	4,3	5,9
B105.0025.S.03	25	100	23	55	4,3	5,9
B105.0010.S.04	10	80	9	50	4,9	6,4
B105.0012.S.04	12	80	11	50	4,9	6,4
B105.0016.S.04	16	80	14	50	4,9	6,4
B105.0020.S.04	20	90	18	55	4,9	6,4
B105.0022.S.04	22	90	20	55	4,9	6,4
B105.0025.S.04	25	100	23	55	4,9	6,4
B105.0010.S.05	10	80	9	50	6,3	7,0
B105.0012.S.05	12	80	11	50	6,3	7,0
B105.0016.S.05	16	80	14	50	6,3	7,0
B105.0020.S.05	20	90	18	55	6,3	7,0
B105.0022.S.05	22	90	20	55	6,3	7,0
B105.0025.S.05	25	100	23	55	6,3	7,0

Weitere Abmessungen auf Anfrage
Further sizes upon request

Abmessungen in mm
Dimensions in mm

Bestellhinweis:

Klemmhalter sind jeweils für rechte und linke Schneidplatten verwendbar.

Ordering note:

Toolholders can be used with right and left hand inserts.

Ersatzteile

Spare Parts

Klemmhalter Toolholder	Spannelement Clamping element	Schraube Screw	Md	b	TORX PLUS®-Schlüssel TORX PLUS® Wrench
B105...03	010.0105.03	030.0000.1157	2 Nm	5,9 mm	T15PL
B105...04	010.0105.04	030.0000.1157	2 Nm	6,4 mm	T15PL
B105...05	010.0105.05	030.0000.1157	2 Nm	7,0 mm	T15PL

Klemmhalter

Toolholder

B105

mit innerer Kühlmittelzufuhr
with through coolant supply

Bohrungs-Ø ab
Stechtiefe
Stechbreite bis

Bore Ø from
Depth of groove
Width of groove up to

0,2 mm
2,5 mm
2 mm

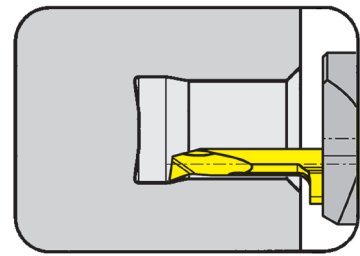

für Schneidplatte
for insert

Typ 105
Type



Abbildung = rechtsschneidend
Picture = right hand cutting version

Stirnseitige Klemmung!
Face clamped insert!

Bestellnummer Part number	d	l ₁	h	l ₄	f ₁	b
BU105.0750.S.03	3/4"	90	17,05	55	4,3	5,9
BU105.0750.S.04	3/4"	90	17,05	55	4,9	6,4
BU105.0750.S.05	3/4"	90	17,05	55	6,3	7,0
BU105.1000.S.03	1"	90	23,40	55	4,3	5,9
BU105.1000.S.04	1"	90	23,40	55	6,4	6,4
BU105.1000.S.05	1"	90	23,40	55	6,3	7,0

Weitere Abmessungen auf Anfrage
Further sizes upon request

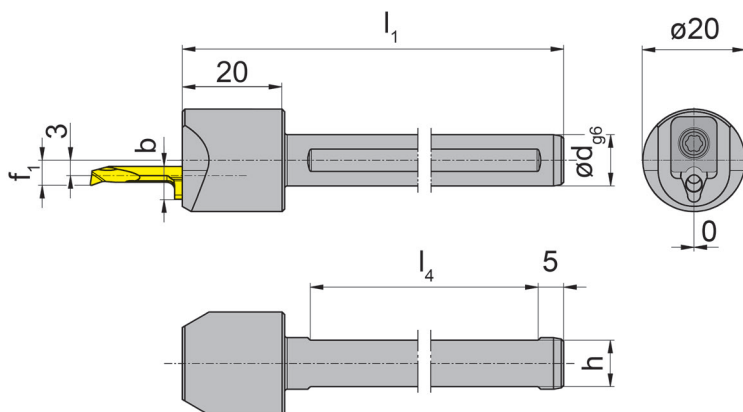
Abmessungen in mm und Zoll
Dimensions in mm and inch

Bestellhinweis:

Klemmhalter sind jeweils für rechte und linke Schneidplatten verwendbar.

Ordering note:

Toolholders can be used with right and left hand inserts.

Das Anzugsdrehmoment der Schrauben beträgt 2 Nm.

Torque specification of the screws = 2 Nm.

Ersatzteile

Spare Parts

Klemmhalter Toolholder	Spannelement Clamping element	Schraube Screw	Md	b	TORX PLUS®-Schlüssel TORX PLUS® Wrench
BU105...03	010.0105.03	030.0000.1157	2 Nm	5,9 mm	T15PL
BU105...04	010.0105.04	030.0000.1157	2 Nm	6,4 mm	T15PL
BU105...05	010.0105.05	030.0000.1157	2 Nm	7,0 mm	T15PL

Grundhalter Graf

Basic toolholder Graf

IR105

mit innerer Kühlmittelzufuhr
with through coolant supply



Bohrungs-Ø ab Bore Ø from 0,2 mm

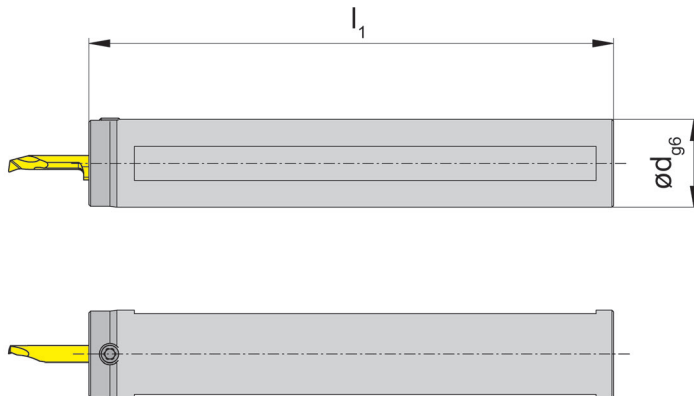

für Schneidplatte
for insert

Typ 105
Type

Abbildung = rechtsschneidend
Picture = right hand cutting version

Bestellnummer Part number	d	l ₁	Maschinentyp Machine type
IR105.34.100	3/4"	100	Citizen
IR105.34.40	3/4"	40	Citizen
IR105.34.50	3/4"	50	Citizen
IR105.34.70	3/4"	70	Citizen
IR105.20.30	20	30	Citizen
IR105.20.50	20	50	Citizen
IR105.10.100	1"	100	Citizen
IR105.10.60	1"	60	Citizen
IR105.16.30	16	30	Star
IR105.16.50	16	50	Star
IR105.16.70	16	70	Star
IR105.22.100	22	100	Star
IR105.22.120	22	120	Star
IR105.22.38	22	38	Star
IR105.22.50	22	50	Star
IR105.22.70	22	70	Star
IR105.20.170	20	170	Tornos
IR105.20.185	20	185	Tornos
IR105.25.100	25	100	Tornos
IR105.25.150	25	150	Tornos
IR105.28.80	28	80	Tornos

Weitere Abmessungen auf Anfrage
Further sizes upon request

Abmessungen in mm und Zoll
Dimensions in mm and inch

Das Anzugsdrehmoment der Schrauben finden Sie in den Technischen Hinweisen.
For torque specification of the screw, please see Technical Instructions.

Ersatzteile

Spare Parts

Grundhalter Graf Basic toolholder Graf	Spannschraube Clamping Screw	TORX PLUS®-Schlüssel TORX PLUS® Wrench
IR105...	6.075T15P	T15PQ

Einbauhalter Graf Cartridge Graf

IR105

mit innerer Kühlmittelzufuhr
with through coolant supply



Bohrungs-Ø ab Bore Ø from 0,2 mm

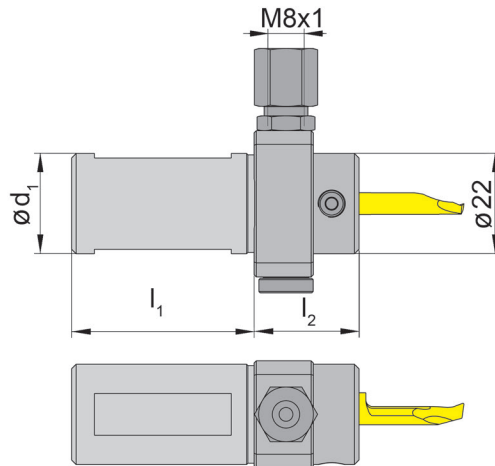

für Schneidplatte
for Insert

Typ 105
Type

Abbildung = rechtsschneidend
Picture = right hand cutting version

Bestellnummer Part number	d ₁	l ₁	l ₂
IR105.1060.IKV	1"	60	25
IR105.1640.IKV	16	40	25
IR105.2040.IKV	20	40	25
IR105.2240.IKV	22	40	25
IR105.2560.IKV	25	60	25
IR105.3440.IKV	3/4"	40	25

Weitere Abmessungen auf Anfrage
Further sizes upon request

Abmessungen in mm und Zoll
Dimensions in mm and inch

Das Anzugsdrehmoment der Schrauben finden Sie in den Technischen Hinweisen.
For torque specification of the screw, please see Technical Instructions.

Ersatzteile Spare Parts

Einbauhalter Graf Cartridge Graf	Spannschraube Clamping Screw	Kühlmittelanschluss Coolant supply	TORX PLUS®-Schlüssel TORX PLUS® Wrench
IR105...	6.075T15P	004.00.19	T15PQ

Klemmhalter

Toolholder

962



Bohrungs-Ø ab	Bore Ø from	0,2 mm
---------------	-------------	--------

Kühlmittelezufuhr über Verschraubung
Coolant through fitting

für Schneidplatte
for Insert

Typ 105
Type

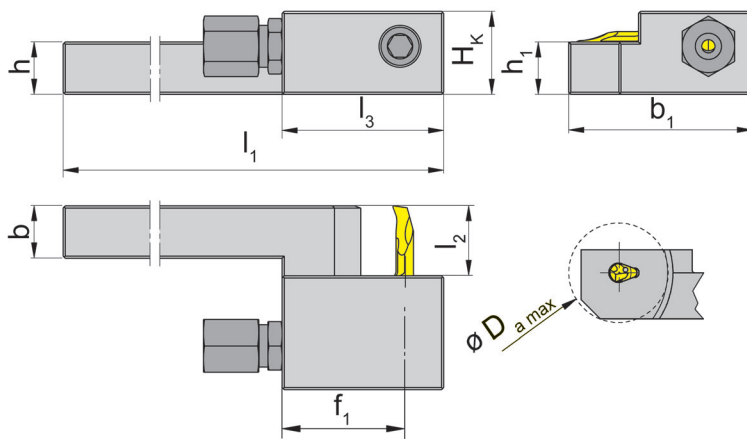

R = rechts wie gezeichnet
R = right hand version shown

L = links spiegelbildlich
L = left hand version

Bestellnummer Part number	h	b	f ₁	l ₁	l ₃	h ₁	H _k	b ₁	l ₂	D _{a max}
962.08.01R	8	8	27	130	37	8	15	42	18	30
962.08.02L	8	8	27	130	37	8	15	42	18	30
962.10.01R	10	10	27	130	37	10	17	42	18	30
962.10.02L	10	10	27	130	37	10	17	42	18	30
962.12.01R	12	12	27	130	37	12	19	42	18	30
962.12.02L	12	12	27	130	37	12	19	42	18	30
962.16.01R	16	16	27	130	37	16	23	42	18	34
962.16.02L	16	16	27	130	37	16	23	42	18	34
962.20.01R	20	20	27	130	37	20	27	42	18	34
962.20.02L	20	20	27	130	37	20	27	42	18	34

Weitere Abmessungen auf Anfrage
Further sizes upon request

Abmessungen in mm
Dimensions in mm

Das Anzugsdrehmoment der Schrauben finden Sie in den Technischen Hinweisen.
For torque specification of the screw, please see Technical Instructions.

Ersatzteile

Spare Parts

Klemmhalter Toolholder	Spannschraube Clamping Screw	Kühlmittelanschluss Coolant supply	TORX PLUS®-Schlüssel TORX PLUS® Wrench
962...	6.075T15P	004.00.14	T15PQ

Klemmhalter

Toolholder

962



Bohrungs-Ø ab Bore Ø from 0,2 mm

Kühlmittelezufuhr über Verschraubung
Coolant through fitting

für Schneidplatte
for Insert

Typ 105
Type

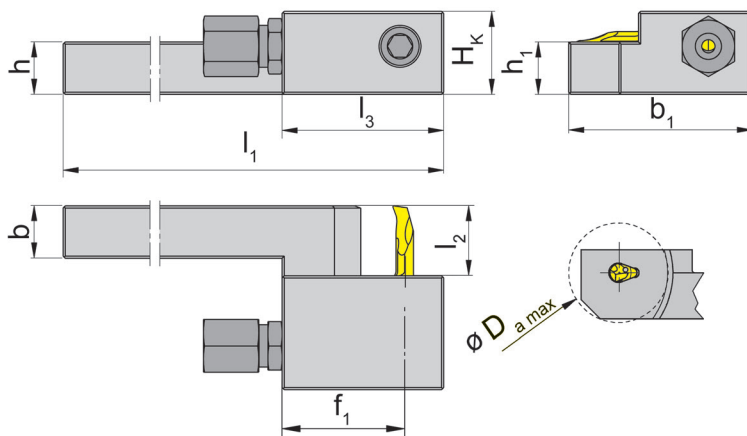

R = rechts wie gezeichnet
R = right hand version shown

L = links spiegelbildlich
L = left hand version

Bestellnummer Part number	h	b	f ₁	l ₁	l ₃	h ₁	H _k	b ₁	l ₂	D _{a max}
962.08.03R	8	8	27	130	37	8	15	57	33	30
962.08.04L	8	8	27	130	37	8	15	57	33	30
962.10.03R	10	10	27	130	37	10	17	57	33	30
962.10.04L	10	10	27	130	37	10	17	57	33	30
962.12.03R	12	12	27	130	37	12	19	57	33	30
962.12.04L	12	12	27	130	37	12	19	57	33	30
962.16.03R	16	16	27	130	37	16	23	57	33	34
962.16.04L	16	16	27	130	37	16	23	57	33	34
962.20.03R	20	20	27	130	37	20	27	57	33	34
962.20.04L	20	20	27	130	37	20	27	57	33	34

Weitere Abmessungen auf Anfrage
Further sizes upon request

Abmessungen in mm
Dimensions in mm

Das Anzugsdrehmoment der Schrauben finden Sie in den Technischen Hinweisen.
For torque specification of the screw, please see Technical Instructions.

Ersatzteile

Spare Parts

Klemmhalter Toolholder	Spannschraube Clamping Screw	Kühlmittelanschluss Coolant supply	TORX PLUS®-Schlüssel TORX PLUS® Wrench
962...	6.075T15P	004.00.14	T15PQ

Klemmhalter

Toolholder

963



Bohrungs-Ø ab	Bore Ø from	0,2 mm
---------------	-------------	--------

Kühlmittelezufuhr über Verschraubung
Coolant through fitting

für Schneidplatte
for Insert

Typ 105
Type

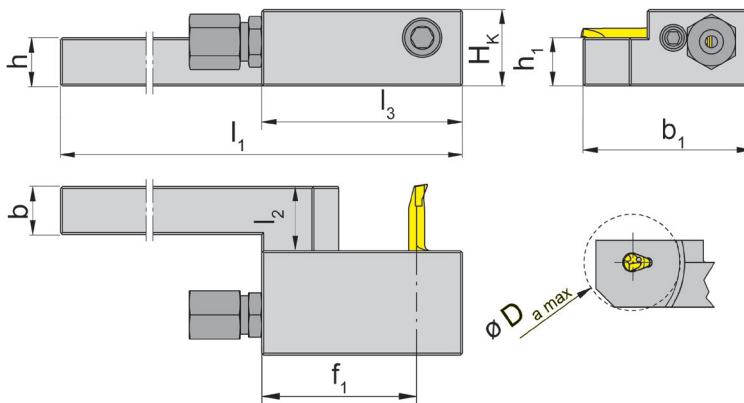

R = rechts wie gezeichnet
R = right hand version shown

L = links spiegelbildlich
L = left hand version

Bestellnummer Part number	h	b	f ₁	l ₁	l ₃	h ₁	H _k	b ₁	l ₂	D _{a max}
963.08.01R	8	8	40	130	50	8	15	42	18	46
963.08.02L	8	8	40	130	50	8	15	42	18	46
963.10.01R	10	10	40	130	50	10	17	42	18	46
963.10.02L	10	10	40	130	50	10	17	42	18	46
963.12.01R	12	12	40	130	50	12	19	42	18	46
963.12.02L	12	12	40	130	50	12	19	42	18	46
963.16.01R	16	16	45	130	50	16	23	42	18	52
963.16.02L	16	16	45	130	50	16	23	42	18	52
963.20.01R	20	20	45	130	50	20	27	42	18	52
963.20.02L	20	20	45	130	50	20	27	42	18	52

Weitere Abmessungen auf Anfrage
Further sizes upon request

Abmessungen in mm
Dimensions in mm

Das Anzugsdrehmoment der Schrauben finden Sie in den Technischen Hinweisen.
For torque specification of the screw, please see Technical Instructions.

Ersatzteile

Spare Parts

Klemmhalter Toolholder	Spannschraube Clamping Screw	Kühlmittelanschluss Coolant supply	TORX PLUS®-Schlüssel TORX PLUS® Wrench
963...	6.075T15P	004.00.14	T15PQ

Klemmhalter

Toolholder

963



Bohrungs-Ø ab Bore Ø from 0,2 mm

Kühlmittelezufuhr über Verschraubung
Coolant through fitting

für Schneidplatte
for insert

Typ 105
Type

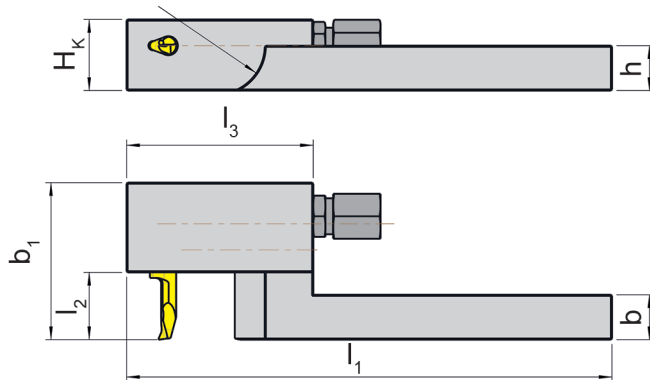

R = rechts wie gezeichnet
R = right hand version shown

L = links spiegelbildlich
L = left hand version

Bestellnummer Part number	h	b	l ₁	l ₃	H _k	b ₁	l ₂	D _{max}
963.12.01.R.IK	12	12	130	50	19	42	18	26
963.12.02.L.IK	12	12	130	50	19	42	18	26
963.16.01.R.IK	16	16	130	55	23	42	18	34
963.16.02.L.IK	16	16	130	55	23	42	18	34

Weitere Abmessungen auf Anfrage
Further sizes upon request

Abmessungen in mm
Dimensions in mm

Das Anzugsdrehmoment der Schrauben finden Sie in den Technischen Hinweisen.
For torque specification of the screw, please see Technical Instructions.

Einstecken und Ausdrehen

Grooving and Boring



A

Grundhalter

Basic toolholder

HC105

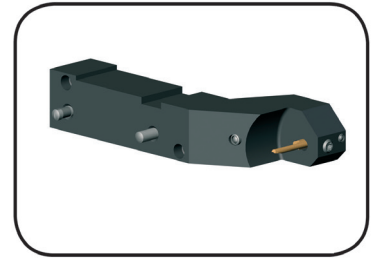

Bohrungs-Ø ab	Bore Ø from	0,2 mm
---------------	-------------	--------

Werkzeug für Tornos
Tool for Tornos

für Schneidplatte
for Insert

Typ 105
Type

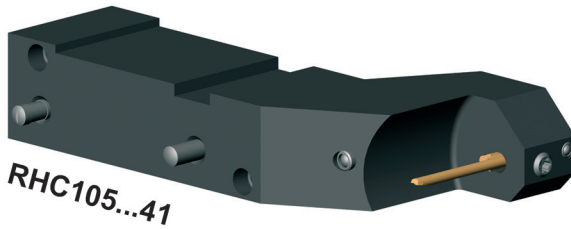
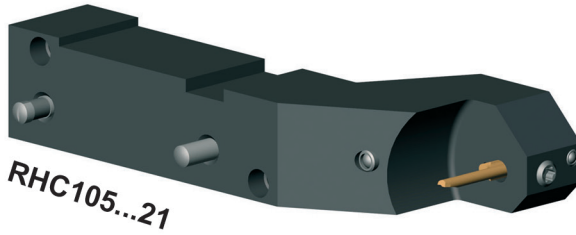

Bestellnummer Part number	Maschinentyp Machine type	Schneidplatte Insert
RHC105.0710.21	EvoDECO 10	105...21 I ₂ bis/up to 15 mm
RHC105.0710.41	EvoDECO 10	105...41 I ₂ bis/up to 25 mm

Weitere Abmessungen auf Anfrage
Further sizes upon request

Abmessungen in mm
Dimensions in mm

Das Anzugsdrehmoment der Schrauben finden Sie in den Technischen Hinweisen.
For torque specification of the screw, please see Technical Instructions.

Ersatzteile

Spare Parts

Grundhalter Basic toolholder	Spannschraube Clamping Screw	SMC Winkelverschraubung SMC angled screw coupling	TORX PLUS®-Schlüssel TORX PLUS® Wrench	Zylinderstift Straight pin
RHC105...	6.075T15P	KQ2L06-M5	T15PQ	020.0518.1610

Grundhalter

Basic toolholder

760

Bohrungs-Ø ab

Bore Ø from

0,2 mm

Werkzeug für Tornos

Tool for Tornos

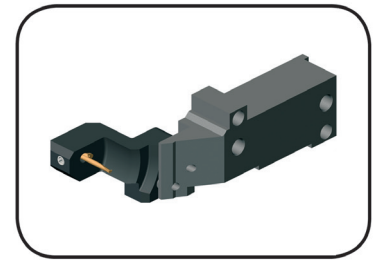
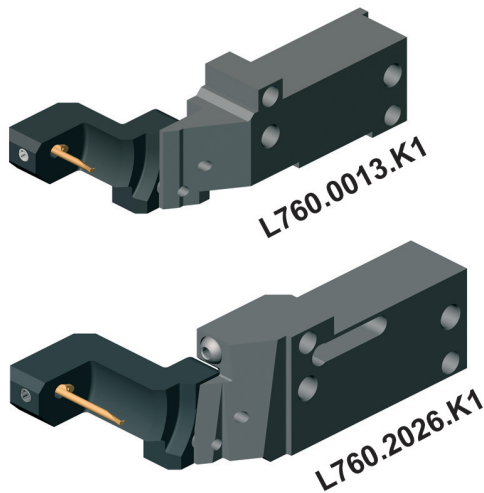
für Kassette
for InsertTyp RKC760
Type

Bestellnummer Part number	Maschinentyp Machine type	Schneidplatte Insert	Kassette Cassette
L760.0013.K1	EvoDECO 16	105...21 I ₂ bis/up to 15 mm	RKC760.0105.21
L760.2026.K1	EvoDECO 20/EvoDECO 32	105...41 I ₂ bis/up to 25 mm	RKC760.0105.41

Weitere Abmessungen auf Anfrage
Further sizes upon requestAbmessungen in mm
Dimensions in mm

Ersatzteile

Spare Parts

Grundhalter Basic toolholder	Inbus-Schlüssel Allen Wrench
L760...	SW5,0 DIN911

Grundhalter Graf

Basic toolholder Graf

G

ohne Einbauhalter
without cartridge

GRAF
WERKZEUGSYSTEME

für einstellbare Halter Graf Typ N und HORN BKT105.2445.01/02
for adjustable holder Graf type N and HORN BKT105.2445.01/02

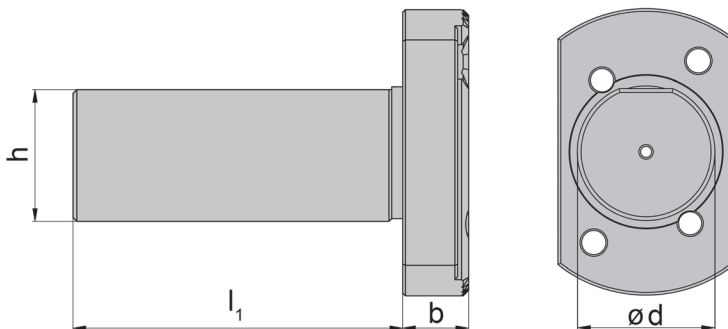

Bestellnummer Part number	d	l ₁	h	b	Maschinentyp Machine type
G.016.021	16	21	14	6	Star
G.016.040	16	40	14	6	Traub/Manurhin
G.034.040	3/4"	40	18	6	Citizen
G.034.050	3/4"	50	18	6	Citizen
G.034.120	3/4"	120	18	6	Citizen
G.020.030	20	30	18	6	Citizen
G.020.040	20	40	18	6	Hanwha
G.020.100	20	100	18	6	Tornos
G.020.150	20	150	18	6	Manurhin/Tornos
G.022.023	22	23	20	6	Star
G022025SR16/20R	22	25	20	12	Star
G.022.030	22	30	20	6	Star
G022030SR32	22	30	20	12	Star
G.022.070	22	70	20	6	Star

Weitere Abmessungen auf Anfrage
Further sizes upon request

Abmessungen in mm und Zoll
Dimensions in mm and inch

Grundhalter Graf

Basic toolholder Graf

G
ohne Einbauhalter
without cartridge



für einstellbare Halter Graf Typ N und HORN BKT105.2445.01/02
for adjustable holder Graf type N and HORN BKT105.2445.01/02

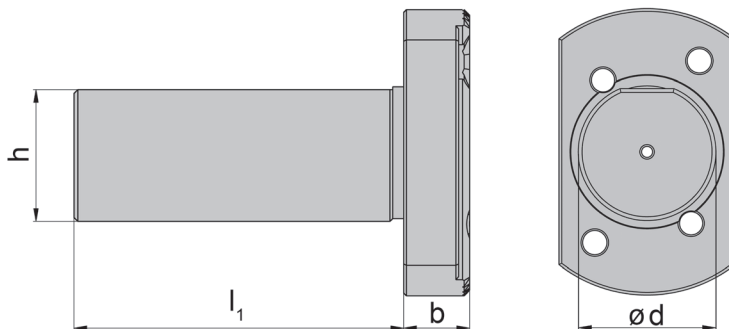

Bestellnummer Part number	d	l ₁	h	b	Maschinentyp Machine type
G.025.060	25	60	23	12	Hanwha
G.025.070	25	70	23	6	Manurhin/Tornos
G.025.100	25	100	23	6	Manurhin/Tornos
G.025.160	25	160	23	6	Manurhin/Tornos
G.010.060	1"	60	23	6	Citizen
G.010.100	1"	100	23	6	Citizen
G.028.006	28	6	26	12	Hanwha
G.028.080	28	80	26	12	Traub
G.030.045	30	45	27	12	Maier
G.033.040	33	40	31	12	Hanwha
G.034.020	34	20	32	12	Maier
G.034.044	34	44	32	12	Maier/Hanwha

Weitere Abmessungen auf Anfrage
Further sizes upon request

Abmessungen in mm und Zoll
Dimensions in mm and inch

Einstecken und Ausdrehen

Grooving and Boring



A

Grundhalter

Basic toolholder

BGT

ohne Einbauhalter
without cartridge

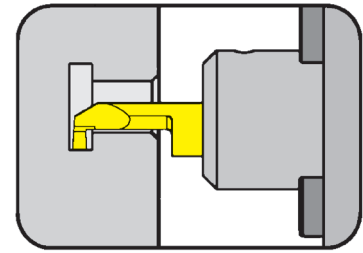

Verstellbare Rundschäfte für Halter BKT105.2445.01/02
Adjustable round shanks for toolholder BKT105.2445.01/02

mit innerer Kühlmittelzufuhr
with through coolant supply

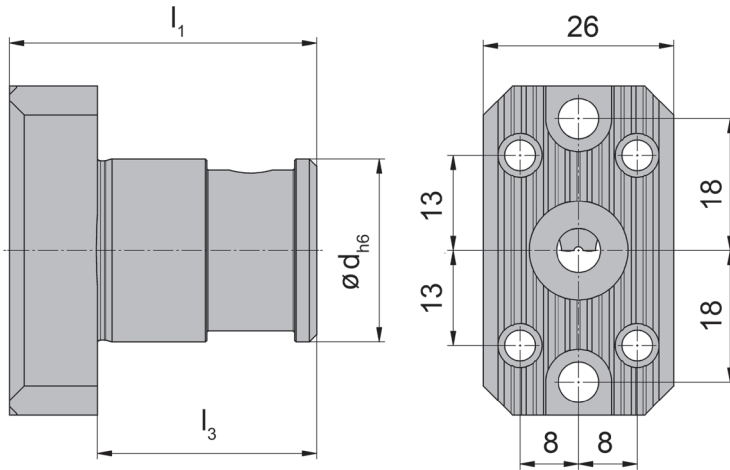

Bestellnummer Part number	d	l_1	l_3	Maschinentyp Machine type
BGT001.C025.30IK	25	42	30	Citizen L20X

Weitere Abmessungen auf Anfrage
Further sizes upon request

Abmessungen in mm
Dimensions in mm

Ersatzteile

Spare Parts

Grundhalter Basic toolholder	Inbus-Schlüssel Allen Wrench	O-Ring O-ring	Zylinderschraube Cylindrical screw
BGT001.C025.30IK	SW4,0 DIN911	7.00.3.00.3601	5.10.912

Zwischenstück Graf Adaptor Graf

Z
ohne Einbauhalter
without cartridge



für einstellbare Halter Graf Typ N und HORN BKT105.2445.01/02
for adjustable holder Graf type N and HORN BKT105.2445.01/02

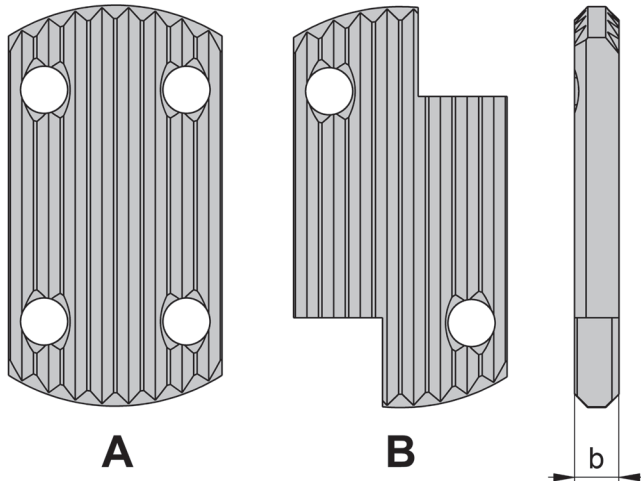

Bestellnummer Part number	b	Form Form
Z.5	5	A
Z.10	10	A
Z.15	15	A
Z.20	20	A
Z.25	25	A
Z.30	30	A
Z5SR16/20R	5	B
Z10SR16/20R	10	B
Z15SR16/20R	15	B
Z20SR16/20R	20	B
Z25SR16/20R	25	B
Z30SR16/20R	30	B

Weitere Abmessungen auf Anfrage
Further sizes upon request

Abmessungen in mm
Dimensions in mm

Einstecken und Ausdrehen

Grooving and Boring



A

Einstellbare Halter

Adjustable holder

BKT

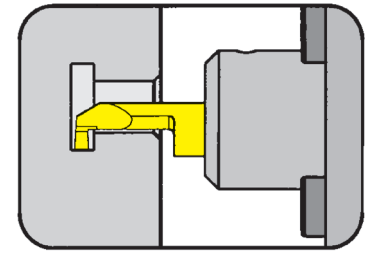

Bohrungs-Ø ab
Stechtiefe bis
Stechbreite bis

Bore Ø from
Depth of groove up to
Width of groove up to

0,2 mm
2,5 mm
2 mm

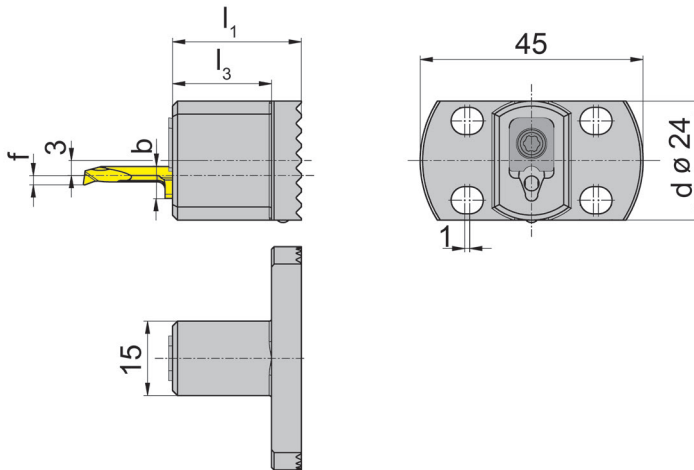

für Schneidplatte
for Insert

Typ 105
Type

Bestellnummer Part number	l_1	d	l_3	b
BKT105.2445.S.03	26	24	20	5,9
BKT105.2445.S.04	26	24	20	6,4
BKT105.2445.S.05	26	24	20	7,0

Weitere Abmessungen auf Anfrage

Further sizes upon request

Abmessungen in mm

Dimensions in mm

f siehe Schneidplatte Typ 105

f see inserts type 105

Ersatzteile

Spare Parts

Einstellbare Halter Adjustable holder	Spannelement Clamping element	Schraube Screw	Md	b	TORX PLUS®-Schlüssel TORX PLUS® Wrench
BKT105...03	010.0105.03	030.0000.1157	2 Nm	5,9 mm	T15PL
BKT105...04	010.0105.04	030.0000.1157	2 Nm	6,4 mm	T15PL
BKT105...05	010.0105.05	030.0000.1157	2 Nm	7,0 mm	T15PL

Einstellbare Halter

Adjustable holder

N



Bohrungs-Ø ab	Bore Ø from	0,2 mm
Stechtiefe bis	Depth of groove up to	2,5 mm
Stechbreite bis	Width of groove up to	2 mm

mit innerer Kühlmittelzufuhr
with through coolant supply

für Schneidplatte
for Insert

Typ 105
Type



Abbildung = rechtsschneidend
Picture = right hand cutting version

Bestellnummer Part number	l_1	l_3
N.09.IK	40	15

Weitere Abmessungen auf Anfrage
Further sizes upon request

Abmessungen in mm
Dimensions in mm

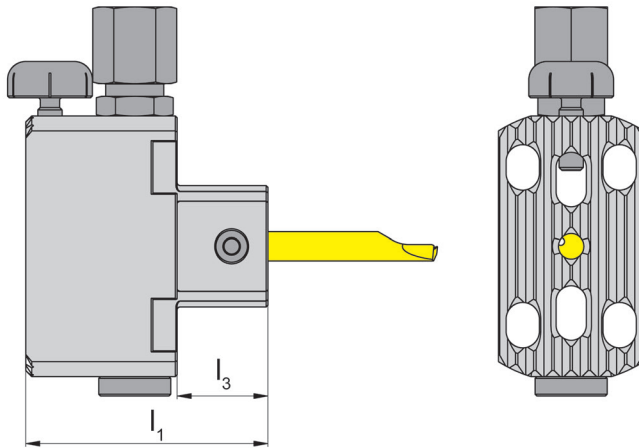
Das Kühlmittelrohr ist nicht im Lieferumfang enthalten - bitte separat bestellen!
Coolant tube is not included - separate order required!

Das Anzugsdrehmoment der Schrauben finden Sie in den Technischen Hinweisen.
For torque specification of the screw, please see Technical Instructions.

Ersatzteile

Spare Parts

Einstellbare Halter Adjustable holder	Spannschraube Clamping Screw	Höhenverstellungsschraube Screw to adjust the height	Kühlmittelanschluss Coolant supply
N09IK	6.075T15P	002.00.69	004.00.19

Einstellbare Halter

Adjustable holder

N



Bohrungs-Ø ab	Bore Ø from	0,2 mm
Stechtiefe bis	Depth of groove up to	2,5 mm
Stechbreite bis	Width of groove up to	2 mm

ohne innere Kühlmittelzufuhr
no through coolant supply

für Schneidplatte
for Insert

Typ 105
Type



Abbildung = rechtsschneidend
Picture = right hand cutting version

Bestellnummer Part number	l_1	l_3
N.09	30	20

Weitere Abmessungen auf Anfrage
Further sizes upon request

Abmessungen in mm
Dimensions in mm

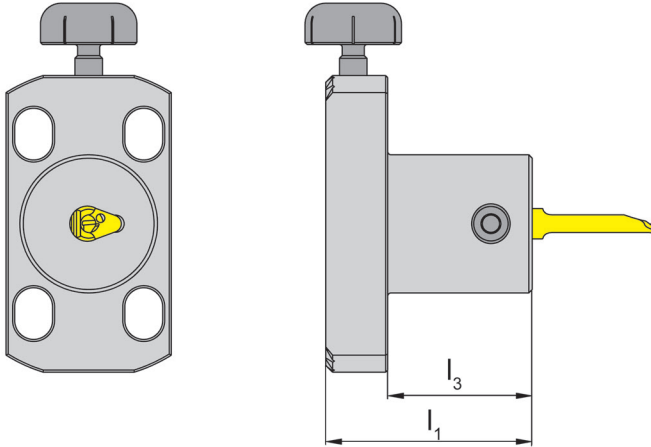
Das Anzugsdrehmoment der Schrauben finden Sie in den Technischen Hinweisen.
For torque specification of the screw, please see Technical Instructions.

Ersatzteile

Spare Parts

Einstellbare Halter Adjustable holder	Spannschraube Clamping Screw	Höhenverstellungsschraube Screw to adjust the height
N09	6.075T15P	002.00.69

Einstellbare Halter

Adjustable holder

N



Bohrungs-Ø ab	Bore Ø from	0,2 mm
Stechtiefe bis	Depth of groove up to	2,5 mm
Stechbreite bis	Width of groove up to	2 mm

mit innerer Kühlmittelzufuhr
with through coolant supply

für Schneidplatte
for insert

Typ 105
Type



Abbildung = rechtsschneidend
Picture = right hand cutting version

Bestellnummer Part number	l_1	l_3
N.73.IK	40	15

Weitere Abmessungen auf Anfrage
Further sizes upon request

Abmessungen in mm
Dimensions in mm

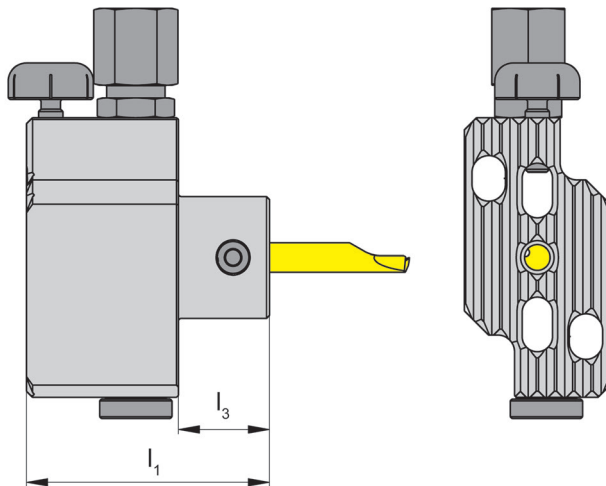
Das Kühlmittelrohr ist nicht im Lieferumfang enthalten - bitte separat bestellen!
Coolant tube is not included - separate order required!

Das Anzugsdrehmoment der Schrauben finden Sie in den Technischen Hinweisen.
For torque specification of the screw, please see Technical Instructions.

Ersatzteile

Spare Parts

Einstellbare Halter Adjustable holder	Spannschraube Clamping Screw	Höhenverstellungsschraube Screw to adjust the height	Kühlmittelanschluss Coolant supply
N73IK	6.075T15P	002.00.69	004.00.19

Einstellbare Halter

Adjustable holder

N



Bohrungs-Ø ab	Bore Ø from	0,2 mm
Stechtiefe bis	Depth of groove up to	2,5 mm
Stechbreite bis	Width of groove up to	2 mm

ohne innere Kühlmittelzufuhr
no through coolant supply

für Schneidplatte
for Insert

Typ 105
Type



Abbildung = rechtsschneidend
Picture = right hand cutting version

Bestellnummer Part number	l_1	l_3
N.73	30	20

Weitere Abmessungen auf Anfrage
Further sizes upon request

Abmessungen in mm
Dimensions in mm

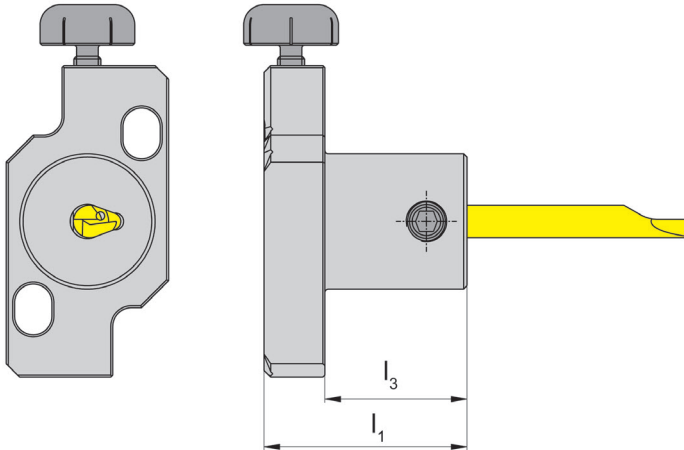
Das Anzugsdrehmoment der Schrauben finden Sie in den Technischen Hinweisen.
For torque specification of the screw, please see Technical Instructions.

Ersatzteile

Spare Parts

Einstellbare Halter Adjustable holder	Spannschraube Clamping Screw	Höhenverstellungsschraube Screw to adjust the height
N73	6.075T15P	002.00.69

Einstellbare Halter

Adjustable holder

N



mit Spannmutter ER16 System Graf
with chucking nut ER16 system Graf

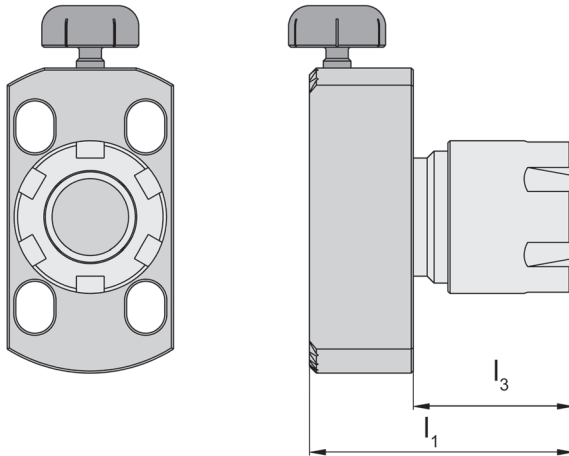

Bestellnummer Part number	l_1	l_3	Spannmutter Clamping nut
N.07	37	18	ER16

Weitere Abmessungen auf Anfrage
Further sizes upon request

Abmessungen in mm
Dimensions in mm

Ersatzteile

Spare Parts

Einstellbare Halter Adjustable holder	Höhenverstellungsschraube Screw to adjust the height	Spannmutter Clamping nut
N07	002.00.69	62.000.16

Einstellbare Halter

Adjustable holder

N



mit Spannmutter ER16 / ER20 System Graf
with chucking nut ER16 / E20 system Graf

mit innerer Kühlmittelzufuhr
with through coolant supply

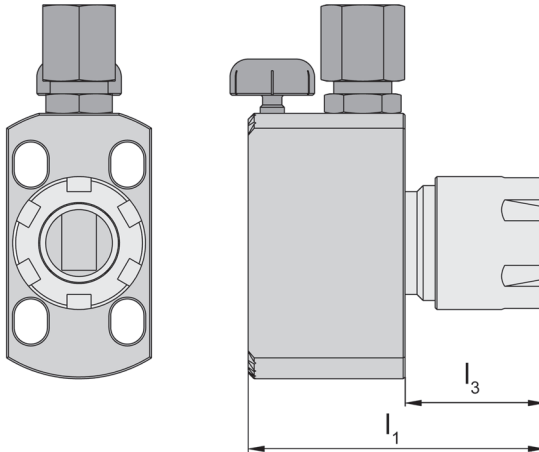

Bestellnummer Part number	l_1	l_3	Spannmutter Clamping nut
N.07.IK	54	18	ER16
N.41.IK	64	26	ER20

Weitere Abmessungen auf Anfrage
Further sizes upon request

Abmessungen in mm
Dimensions in mm

Das Kühlmittelrohr ist nicht im Lieferumfang enthalten - bitte separat bestellen!
Coolant tube is not included - separate order required!

Ersatzteile

Spare Parts

Einstellbare Halter Adjustable holder	Dichtscheibensatz D3 Sealing disc set D3	Höhenverstellungsschraube Screw to adjust the height	Kühlmittelanschluss Coolant supply	Spannmutter Clamping nut
N07IK	64.600.16.3-10	002.00.69	004.00.19	62.000.16
N41IK	64.600.20.3-13	002.00.69	004.00.19	62.000.20

Kühlmittelanschluss Standard für Rohr Ø 6 mm

Standard connection for coolant supply for pipe Ø 6 mm

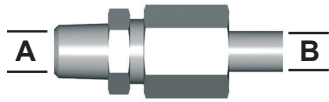

Kühlmittelanschluss, gerade
Connection for coolant supply
straight screwed

A	B	Bestellnummer Part number
M8 x 1	ø 6 mm	004.00.19
G1/8"	ø 6 mm	004.00.14

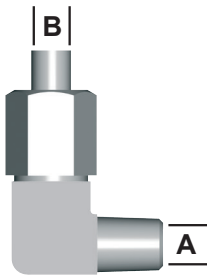

Kühlmittelanschluss,
winkelig fest
Connection for coolant supply
angled and fix

A	B	Bestellnummer Part number
M8 x 1	ø 6 mm	004.00.22
G1/8"	ø 6 mm	004.00.33

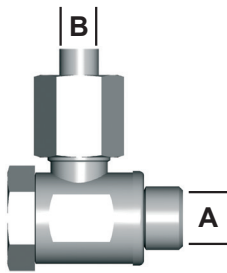

Schwenkverschraubung
Swivelling screw-fitting

A	B	Bestellnummer Part number
M8 x 1	ø 6 mm	004.00.61
G1/8"	ø 6 mm	004.00.16

Kühlmittelanschluss Schnellkupplung

Clip connection for coolant supply

Schnellkupplung
Quick connector

M10 x 1 - 004.00.49

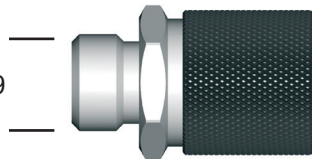

Stecker
Plug

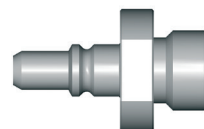

M8 x 1 - 004.00.56
G1/8" - 004.00.57

Stecker
Plug

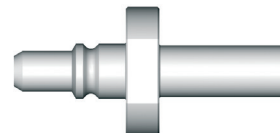

Ø 6 mm - 004.00.59

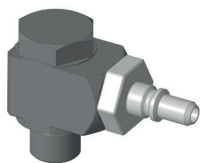

Schnellkupplung, männlich
Quick coupling, male

		Bestellnummer Part number
M8 x 1	ø 3 mm	004.00.53
G1/8"	ø 3 mm	004.00.52

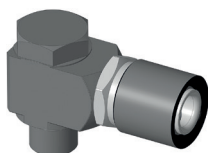

Schnellkupplung, weiblich
Quick coupling, female

		Bestellnummer Part number
M8 x 1	ø 4,8 mm	004.00.81
G1/8"	ø 4,8 mm	004.00.80

Schneidplatte

Insert

105

zur Feinstbearbeitung
for ultrafine machining

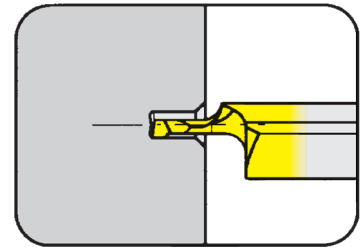

Bohrungs-Ø ab	Bore Ø from	0,2 mm
---------------	-------------	--------

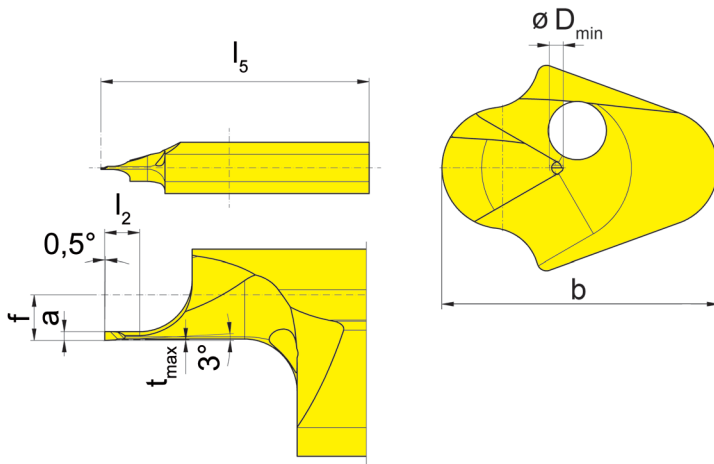

für Klemmhalter
for Toolholder

- Typ H105
Type HC105
B105/BU105
BKT
IR105
962
AIH
963
N



R = rechts wie gezeichnet
R = right hand version shown

Bestellnummer Part number	f	a	b	l ₂	l ₅	t _{max}	D _{min}	MG12	AN25	ES15
R105.9013.000.0.02	1,3	0,17	5,9	1	23	0,015	0,2		Δ	Δ
R105.9013.000.0.03	1,3	0,25	5,9	1	23	0,015	0,3		Δ	Δ
R105.9013.000.0.05	1,3	0,40	5,9	2	23	0,020	0,5	Δ	Δ	Δ
R105.9013.000.0.07	1,3	0,60	5,9	2	23	0,020	0,7		Δ	▲

▲ ab Lager / on stock Δ 4 Wochen / 4 weeks x auf Anfrage / upon request

● empfohlen / recommended

o bedingt einsetzbar / alternative recommendation

- nicht geeignet / not suitable

□ unbeschichtete HM-Sorten / uncoated grades

■ beschichtete HM-Sorten / coated grades

■ bestückt/Cermet / brazed/Cermet

Abmessungen in mm

Dimensions in mm

Ausführung R oder L angeben

State R or L version

Weitere Abmessungen auf Anfrage

Further sizes upon request

P	o	●	●
M	-	o	o
K	-	-	●
N	-	-	-
S	-	-	-
H	-	-	-

HM-Sorten
Carbide grades

Bohrung-Drehen

Boring and Profiling



A

Schneidplatte

Insert

105

zur Feinstbearbeitung
for ultrafine machining

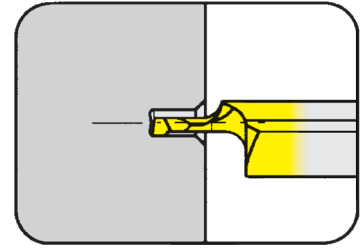

Bohrungs-Ø ab	Bore Ø from	1 mm
---------------	-------------	------

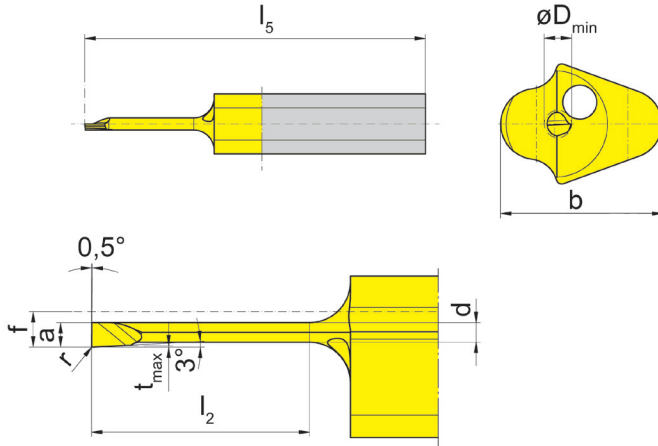

für Klemmhalter
for Toolholder

Typ H105
Type HC105
B105/BU105
BKT
IR105
962
AIH
963
N



R = rechts wie gezeichnet
R = right hand version shown

Bestellnummer Part number	r	f	a	d	b	l ₂	l ₅	t _{max}	D _{min}		AN25	ES15
R105.9013.000.0.1	-	1,3	0,9	0,72	5,9	4	25	0,05	1,0		Δ	▲
R105.9013.000.2.1	-	1,3	0,9	0,72	5,9	8	25	0,05	1,0		Δ	Δ
R105.9013.003.0.1	0,03	1,3	0,9	0,72	5,9	4	25	0,05	1,0		Δ	Δ
R105.9013.003.2.1	0,03	1,3	0,9	0,72	5,9	8	25	0,05	1,0		▲	Δ
R105.9013.000.0.15	-	1,3	1,4	1,15	5,9	6	25	0,10	1,5		Δ	▲
R105.9013.000.1.15	-	1,3	1,4	1,15	5,9	9	25	0,10	1,5		Δ	Δ
R105.9013.003.0.15	0,03	1,3	1,4	1,15	5,9	6	25	0,10	1,5		Δ	▲
R105.9013.003.1.15	0,03	1,3	1,4	1,15	5,9	9	25	0,10	1,5		Δ	Δ

▲ ab Lager / on stock Δ 4 Wochen / 4 weeks x auf Anfrage / upon request

● empfohlen / recommended

o bedingt einsetzbar / alternative recommendation

- nicht geeignet / not suitable

■ unbeschichtete HM-Sorten / uncoated grades

■ beschichtete HM-Sorten / coated grades

■ bestückt/Cermet / brazed/Cermet

Abmessungen in mm

Dimensions in mm

Ausführung R oder L angeben

State R or L version

Weitere Abmessungen auf Anfrage

Further sizes upon request

P	●	●
M	o	o
K	-	●
N	-	-
S	-	-
H	-	-

HM-Sorten
Carbide grades

Schneidplatte

Insert

105

zur Feinstbearbeitung
for ultrafine machining

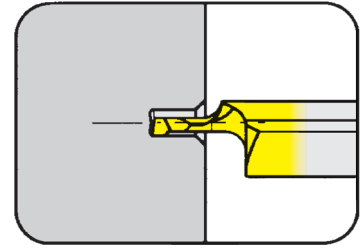

Bohrungs-Ø ab	Bore Ø from	2 mm
---------------	-------------	------

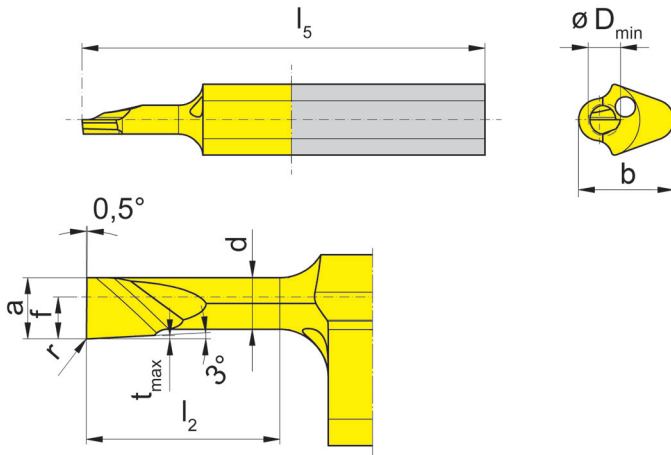

für Klemmhalter
for Toolholder

- Typ H105
Type HC105
B105/BU105
BKT
IR105
962
AIH
963
N



R = rechts wie gezeichnet
R = right hand version shown

Bestellnummer Part number	r	f	a	d	b	l ₂	l ₅	t _{max}	D _{min}	MG12	AN25	ES15
R105.9013.000.0.2	-	1,3	1,9	1,6	5,9	6	25	0,1	2,0		Δ	▲
R105.9013.000.2.2	-	1,3	1,9	1,6	5,9	12	30	0,1	2,0		Δ	Δ
R105.9013.003.0.2	0,03	1,3	1,9	1,6	5,9	6	25	0,1	2,0		Δ	▲
R105.9013.003.2.2	0,03	1,3	1,9	1,6	5,9	12	30	0,1	2,0		Δ	Δ
R105.9013.000.0.25	-	1,3	2,3	2,0	5,9	6	25	0,1	2,5		Δ	Δ
R105.9013.000.2.25	-	1,3	2,3	2,0	5,9	12	30	0,1	2,5	Δ	Δ	Δ
R105.9013.000.3.25	-	1,3	2,3	2,0	5,9	16	35	0,1	2,5		Δ	Δ
R105.9013.003.0.25	0,03	1,3	2,3	2,0	5,9	6	25	0,1	2,5		Δ	▲
R105.9013.003.2.25	0,03	1,3	2,3	2,0	5,9	12	30	0,1	2,5	Δ	Δ	Δ
R105.9013.003.3.25	0,03	1,3	2,3	2,0	5,9	16	35	0,1	2,5		Δ	Δ

▲ ab Lager / on stock Δ 4 Wochen / 4 weeks x auf Anfrage / upon request

● empfohlen / recommended

o bedingt einsetzbar / alternative recommendation

- nicht geeignet / not suitable

■ unbeschichtete HM-Sorten / uncoated grades

■ beschichtete HM-Sorten / coated grades

■ bestückt/Cermet / brazed/Cermet

Abmessungen in mm

Dimensions in mm

Ausführung R oder L angeben

State R or L version

Weitere Abmessungen auf Anfrage

Further sizes upon request

P	o	●	●
M	-	o	o
K	-	-	●
N	-	-	-
S	-	-	-
H	-	-	-

HM-Sorten
Carbide grades

Bohrung-Drehen

Boring and Profiling



A

Schneidplatte

Insert

105

zur Feinstbearbeitung
for ultrafine machining

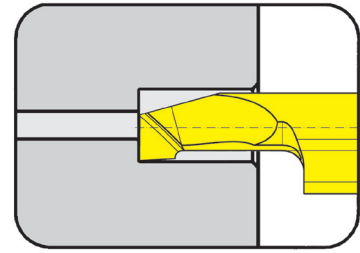

Bohrungs-Ø ab	Bore Ø from	3 mm
---------------	-------------	------

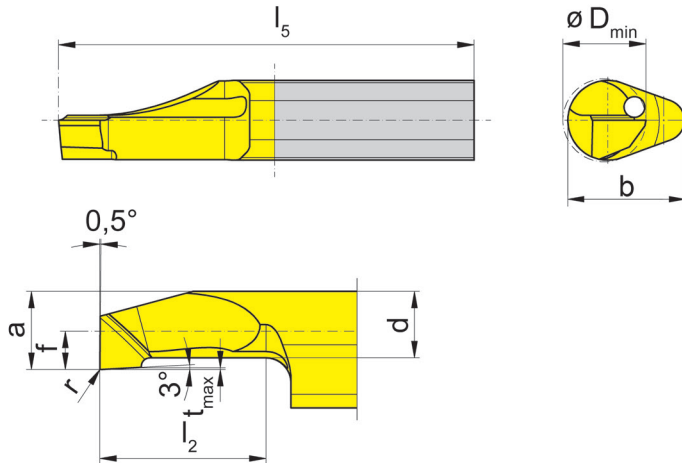

für Klemmhalter
for Toolholder

Typ H105
Type HC105
B105/BU105
BKT
IR105
962
AIH
963
N



R = rechts wie gezeichnet
R = right hand version shown

Bestellnummer Part number	r	f	a	d	b	l ₂	l ₅	t _{max}	D _{min}		AN25	ES15
R105.9013.000.1.3	-	1,3	2,6	2,3	5,9	10	25	0,1	3		Δ	▲
R105.9013.000.3.3	-	1,3	2,6	2,3	5,9	20	35	0,1	3		Δ	Δ
R105.9013.003.1.3	0,03	1,3	2,6	2,3	5,9	10	25	0,1	3		Δ	▲
R105.9013.003.3.3	0,03	1,3	2,6	2,3	5,9	20	35	0,1	3		Δ	▲
R105.9019.000.1.4	-	1,9	3,7	3,2	6,4	10	25	0,1	4		▲	Δ
R105.9019.000.3.4	-	1,9	3,7	3,2	6,4	20	35	0,1	4		Δ	Δ
R105.9019.003.1.4	0,03	1,9	3,7	3,2	6,4	10	25	0,1	4		▲	Δ
R105.9019.003.3.4	0,03	1,9	3,7	3,2	6,4	20	35	0,1	4		▲	Δ

▲ ab Lager / on stock Δ 4 Wochen / 4 weeks x auf Anfrage / upon request

● empfohlen / recommended

o bedingt einsetzbar / alternative recommendation

- nicht geeignet / not suitable

■ unbeschichtete HM-Sorten / uncoated grades

■ beschichtete HM-Sorten / coated grades

■ bestückt/Cermet / brazed/Cermet

Abmessungen in mm

Dimensions in mm

Ausführung R oder L angeben

State R or L version

Weitere Abmessungen auf Anfrage

Further sizes upon request

P	●	●
M	o	o
K	-	●
N	-	-
S	-	-
H	-	-

HM-Sorten
Carbide grades

Schneidplatte

Insert

105

zur Feinstbearbeitung
for ultrafine machining

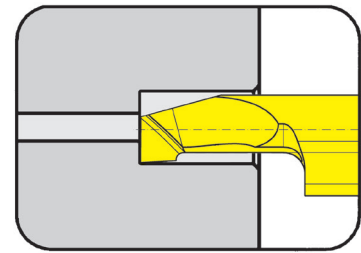

Bohrungs-Ø ab	Bore Ø from	5 mm
---------------	-------------	------

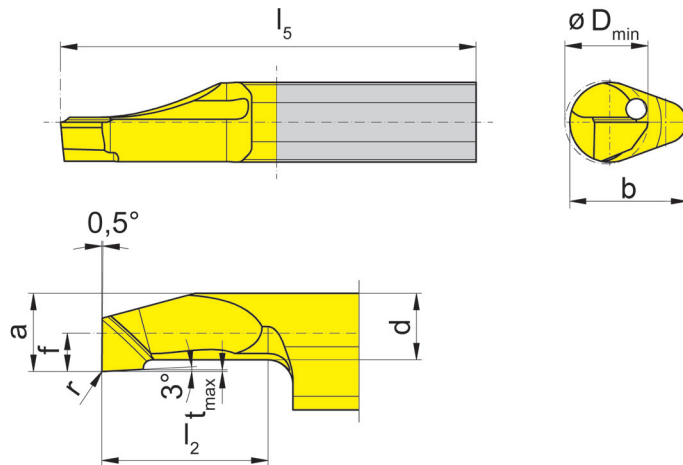

für Klemmhalter
for Toolholder

Typ H105
Type HC105
B105/BU105
BKT
IR105
962
AIH
963
N



R = rechts wie gezeichnet
R = right hand version shown

Bestellnummer Part number	r	f	a	d	b	l_2	l_5	t_{max}	D_{min}		AN25	ES15
R105.9023.000.1.5	-	2,3	4,7	4	7	10	25	0,1	5		Δ	Δ
R105.9023.000.3.5	-	2,3	4,7	4	7	20	35	0,1	5		Δ	Δ
R105.9023.000.5.5	-	2,3	4,7	4	7	30	45	0,1	5		Δ	Δ
R105.9023.003.1.5	0,03	2,3	4,7	4	7	10	25	0,1	5		Δ	Δ
R105.9023.003.3.5	0,03	2,3	4,7	4	7	20	35	0,1	5		Δ	Δ
R105.9023.003.5.5	0,03	2,3	4,7	4	7	30	45	0,1	5		Δ	Δ

▲ ab Lager / on stock Δ 4 Wochen / 4 weeks x auf Anfrage / upon request

● empfohlen / recommended

o bedingt einsetzbar / alternative recommendation

- nicht geeignet / not suitable

■ unbeschichtete HM-Sorten / uncoated grades

■ beschichtete HM-Sorten / coated grades

■ bestückt/Cermet / brazed/Cermet

Abmessungen in mm

Dimensions in mm

Ausführung R oder L angeben

State R or L version

Weitere Abmessungen auf Anfrage

Further sizes upon request

P	●	●
M	o	o
K	-	●
N	-	-
S	-	-
H	-	-

HM-Sorten
Carbide grades

Schneidplatte

Insert

105

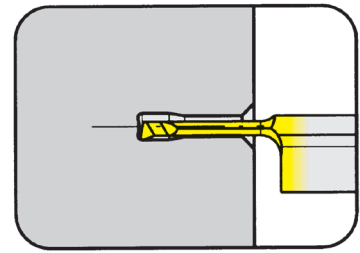

Bohrungs-Ø ab

Bore Ø from

1 mm

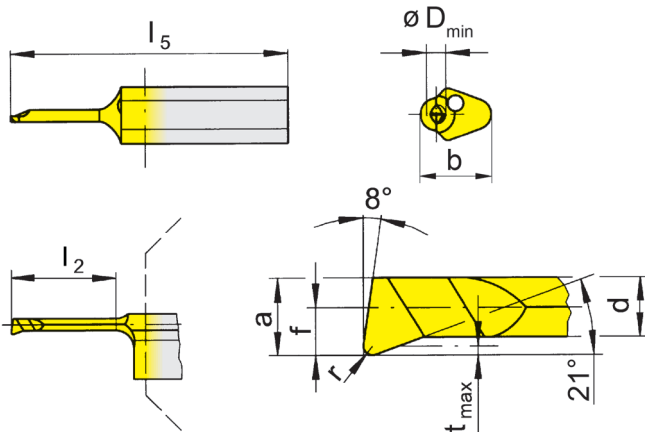
für Klemmhalter
for Toolholder

Typ H105
Type HC105
B105/BU105
BKT
IR105
962
AIH
963
N

R = rechts wie gezeichnet
R = right hand version shown

L = links spiegelbildlich
L = left hand version

Bestellnummer Part number	r	f	a	d	b	l ₂	l ₅	t _{max}	D _{min}	MG12	EG35	TF45	TH35	TI25	TN35
R/L105.1805.005.0.1	0,05	0,5	0,9	0,65	5,9	4	25	0,10	1,0		▲/Δ	▲/▲			
R/L105.1805.005.1.1	0,05	0,5	0,9	0,65	5,9	6	25	0,10	1,0		Δ/Δ	▲/▲			
R/L105.1805.005.2.1	0,05	0,5	0,9	0,65	5,9	8	25	0,10	1,0		Δ/Δ	▲/▲	Δ/x		
R/L105.1805.0.1	0,10	0,5	0,9	0,65	5,9	4	25	0,10	1,0	▲/Δ	▲/▲	Δ/x		▲/▲	▲/▲
R/L105.1805.1.1	0,10	0,5	0,9	0,65	5,9	6	25	0,10	1,0	Δ/x	▲/▲			▲/▲	▲/▲
R/L105.1805.2.1	0,10	0,5	0,9	0,65	5,9	8	25	0,10	1,0		▲/Δ			▲/Δ	▲/▲
R/L105.1813.005.0.15	0,05	1,3	1,4	1,10	5,9	6	25	0,15	1,5		▲/Δ	▲/▲	Δ/Δ		
R/L105.1813.005.1.15	0,05	1,3	1,4	1,10	5,9	9	25	0,15	1,5		▲/Δ	▲/▲	Δ/x		
R/L105.1813.005.2.15	0,05	1,3	1,4	1,10	5,9	12	30	0,15	1,5		▲/Δ	▲/Δ	Δ/x		
R/L105.1813.01.0.15	0,10	1,3	1,4	1,10	5,9	6	25	0,15	1,5		▲/Δ		▲/▲	▲/▲	
R/L105.1813.01.1.15	0,10	1,3	1,4	1,10	5,9	9	25	0,15	1,5		Δ/Δ		▲/▲	▲/▲	
R/L105.1813.01.2.15	0,10	1,3	1,4	1,10	5,9	12	30	0,15	1,5		Δ/Δ		▲/▲	▲/▲	

▲ ab Lager / on stock Δ 4 Wochen / 4 weeks x auf Anfrage / upon request

● empfohlen / recommended

o bedingt einsetzbar / alternative recommendation

- nicht geeignet / not suitable

■ unbeschichtete HM-Sorten / uncoated grades

■ beschichtete HM-Sorten / coated grades

■ bestückt/Cermet / brazed/Cermet

Abmessungen in mm

Dimensions in mm

Ausführung R oder L angeben

State R or L version

Weitere Abmessungen auf Anfrage

Further sizes upon request

	P	M	K	N	S	H
MG12	○	-	-	-	-	-
EG35	●	●	●	●	●	●
TF45	●	●	●	●	●	●
TH35	●	●	●	●	●	●
TI25	●	●	●	●	●	●
TN35	●	●	●	●	●	●

HM-Sorten
Carbide grades

Schneidplatte

Insert

105

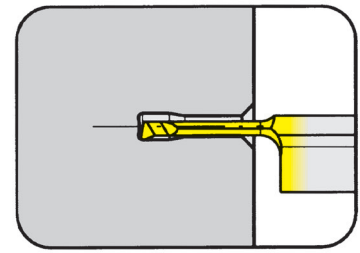

Bohrungs-Ø ab	Bore Ø from	2 mm
---------------	-------------	------

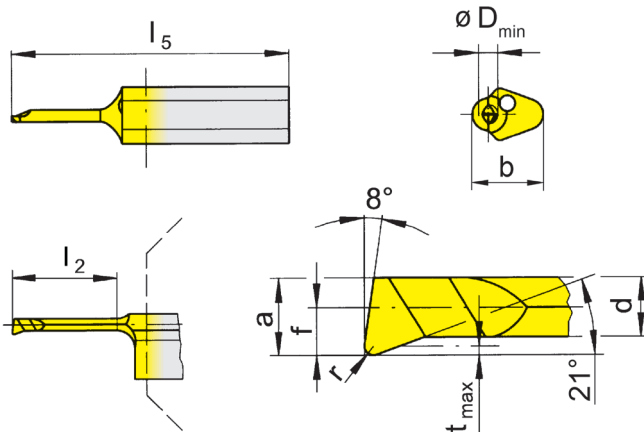

für Klemhalter
for Toolholder

Typ H105
Type HC105
B105/BU105
BKT
IR105
962
AIH
963
N

R = rechts wie gezeichnet
R = right hand version shown

L = links spiegelbildlich
L = left hand version

Bestellnummer Part number	r	f	a	d	b	l ₂	l ₅	t _{max}	D _{min}	MG12	EG35	TF45	TH35	TI25	TN35
R/L105.1809.005.0.2	0,05	1,0	1,9	1,60	5,9	6	25	0,15	2,0	▲/▲	▲/▲	▲/▲	▲/▲	▲/▲	▲/▲
R/L105.1809.005.1.2	0,05	1,0	1,9	1,60	5,9	9	25	0,15	2,0	▲/▲	▲/▲	▲/▲	▲/▲	▲/▲	▲/▲
R/L105.1809.005.2.2	0,05	1,0	1,9	1,60	5,9	12	30	0,15	2,0	▲/▲	▲/▲	▲/▲	▲/▲	▲/▲	▲/▲
R/L105.1809.01.0.2	0,10	1,0	1,9	1,60	5,9	6	25	0,15	2,0	▲/▲	▲/▲	▲/▲	▲/▲	▲/▲	▲/▲
R/L105.1809.01.1.2	0,10	1,0	1,9	1,60	5,9	9	25	0,15	2,0	▲/▲	▲/▲	▲/▲	▲/▲	▲/▲	▲/▲
R/L105.1809.01.2.2	0,10	1,0	1,9	1,60	5,9	12	30	0,15	2,0	▲/▲	▲/▲	▲/▲	▲/▲	▲/▲	▲/▲
R/L105.1809.0.2	0,15	1,0	1,9	1,60	5,9	6	25	0,15	2,0	▲/▲	▲/▲	▲/▲	▲/▲	▲/▲	▲/▲
R/L105.1809.1.2	0,15	1,0	1,9	1,60	5,9	9	25	0,15	2,0	▲/▲	▲/▲	▲/▲	▲/▲	▲/▲	▲/▲
R/L105.1809.2.2	0,15	1,0	1,9	1,60	5,9	12	30	0,15	2,0	▲/▲	▲/▲	▲/▲	▲/▲	▲/▲	▲/▲
R/L105.1813.005.0.25	0,05	1,3	2,3	1,95	5,9	6	25	0,15	2,5	▲/▲	▲/▲	▲/▲	▲/▲	▲/▲	▲/▲
R/L105.1813.005.1.25	0,05	1,3	2,3	1,95	5,9	9	25	0,15	2,5	▲/▲	▲/▲	▲/▲	▲/▲	▲/▲	▲/▲
R/L105.1813.005.2.25	0,05	1,3	2,3	1,95	5,9	12	30	0,15	2,5	▲/▲	▲/▲	▲/▲	▲/▲	▲/▲	▲/▲
R/L105.1813.005.3.25	0,05	1,3	2,3	1,95	5,9	16	35	0,15	2,5	▲/▲	▲/▲	▲/▲	▲/▲	▲/▲	▲/▲
P	○	●	●	●	●	●	●	●	●	●	●	●	●	●	●
M	-	●	●	●	●	●	●	●	●	●	●	●	●	●	●
K	-	○	●	●	●	●	●	●	●	●	●	●	●	●	●
N	-	-	●	●	●	●	●	●	●	●	●	●	●	●	●
S	-	-	●	●	●	●	●	●	●	●	●	●	●	●	●
H	-	-	-	-	-	-	-	-	-	-	-	-	-	-	-

Abmessungen in mm
Dimensions in mm

Ausführung R oder L angeben
State R or L version

Weitere Abmessungen auf Anfrage
Further sizes upon request

HM-Sorten
Carbide grades

Bohrung-Drehen

Boring and Profiling



Schneidplatte

105

Insert

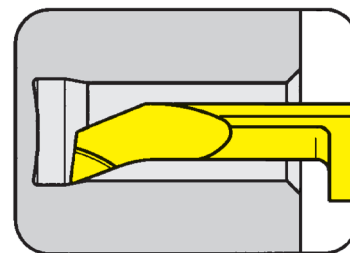

Bohrungs-Ø ab	Bore Ø from	3 mm
---------------	-------------	------

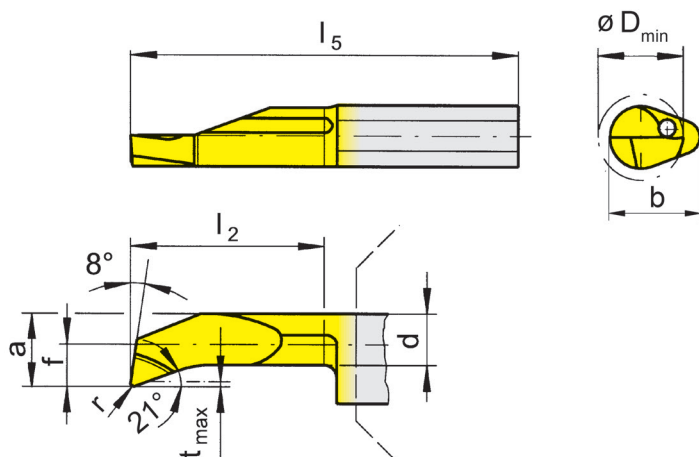

für Klemhalter
for Toolholder

- Typ H105
Type HC105
B/BU105
VDI
B105C
B105TS
IR105
962
AIH
963
N

R = rechts wie gezeichnet
R = right hand version shown

L = links spiegelbildlich
L = left hand version

Bestellnummer Part number	r	f	a	d	b	l ₂	l ₅	t _{max}	D _{min}	MG12	EG35	TF45	TH35	TI25	TN35
R/L105.1813.005.1.3	0,05	1,3	2,6	2,3	5,9	10	25	0,15	3		▲/Δ	▲/▲	Δ/x	Δ/x	Δ/x
R/L105.1813.005.2.3	0,05	1,3	2,6	2,3	5,9	15	30	0,15	3		Δ/Δ	▲/▲		x/x	Δ/x
R/L105.1813.005.3.3	0,05	1,3	2,6	2,3	5,9	20	35	0,15	3		Δ/Δ	▲/▲		Δ/x	x/x
R/L105.1813.01.1.3	0,10	1,3	2,6	2,3	5,9	10	25	0,15	3		▲/Δ		▲/▲	▲/▲	
R/L105.1813.01.2.3	0,10	1,3	2,6	2,3	5,9	15	30	0,15	3		Δ/Δ		▲/▲	▲/▲	
R/L105.1813.01.3.3	0,10	1,3	2,6	2,3	5,9	20	35	0,15	3		Δ/Δ		▲/▲	▲/▲	
R/L105.1813.1.3	0,20	1,3	2,6	2,3	5,9	10	25	0,15	3	▲/▲	▲/▲	Δ/x	▲/▲	▲/▲	▲/▲
R/L105.1813.2.3	0,20	1,3	2,6	2,3	5,9	15	30	0,15	3	▲/▲	▲/▲	Δ/x	▲/▲	▲/▲	▲/▲
R/L105.1813.3.3	0,20	1,3	2,6	2,3	5,9	20	35	0,15	3	▲/Δ	▲/▲	x/x	▲/▲	▲/▲	▲/▲
R/L105.1819.005.1.4	0,05	1,9	3,7	2,9	6,4	10	25	0,30	4		▲/Δ	▲/▲	Δ/Δ	Δ/x	x/x
R/L105.1819.005.2.4	0,05	1,9	3,7	2,9	6,4	15	30	0,30	4		▲/Δ	▲/▲		x/x	x/x
R/L105.1819.005.3.4	0,05	1,9	3,7	2,9	6,4	20	35	0,30	4		▲/Δ	▲/▲	Δ/Δ		x/x
R/L105.1819.1.4	0,20	1,9	3,7	2,9	6,4	10	25	0,30	4	▲/▲	▲/▲		▲/▲	▲/▲	▲/▲
R/L105.1819.2.4	0,20	1,9	3,7	2,9	6,4	15	30	0,30	4	▲/▲	▲/▲	Δ/x	▲/▲	▲/▲	▲/▲
R/L105.1819.3.4	0,20	1,9	3,7	2,9	6,4	20	35	0,30	4	▲/▲	▲/▲	Δ/x	▲/▲	▲/▲	▲/▲

- ▲ ab Lager / on stock Δ 4 Wochen / 4 weeks x auf Anfrage / upon request
- empfohlen / recommended
- o bedingt einsetzbar / alternative recommendation
- nicht geeignet / not suitable
- unbeschichtete HM-Sorten / uncoated grades
- beschichtete HM-Sorten / coated grades
- bestückt/Cermet / brazed/Cermet

	P	M	K	N	S	H
MG12	o	●	●	●	●	●
EG35	-	●	●	●	●	●
TF45	-	o	●	●	●	●
TH35	-	-	●	●	●	●
TI25	-	-	●	●	●	●
TN35	-	-	-	-	-	-

Abmessungen in mm
Dimensions in mm

Ausführung R oder L angeben
State R or L version

Weitere Abmessungen auf Anfrage
Further sizes upon request

HM-Sorten
Carbide grades

Schneidplatte

Insert

105

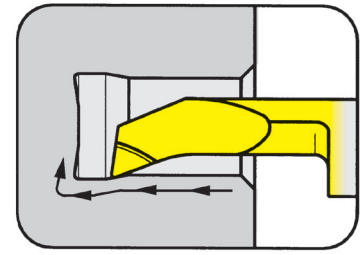

Bohrungs-Ø ab	Bore Ø from	5 mm
---------------	-------------	------

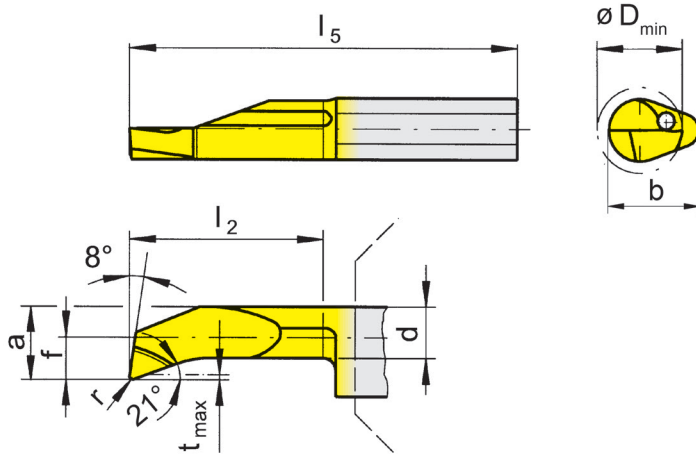

für Klemhalter
for Toolholder

- Typ H105
Type HC105
B105/BU105
BKT
IR105
962
AIH
963
N

R = rechts wie gezeichnet
R = right hand version shown

L = links spiegelbildlich
L = left hand version

Bestellnummer Part number	r	f	a	d	b	l ₂	l ₅	t _{max}	D _{min}	MG12	EG35	TF45	TH35	TI25	TN35
R/L105.1823.005.1.5	0,05	2,3	4,7	4	7	10	25	0,5	5		Δ/Δ	▲/▲	x/x		x/x
R/L105.1823.005.2.5	0,05	2,3	4,7	4	7	15	30	0,5	5		▲/Δ	▲/▲	Δ/x		Δ/x
R/L105.1823.005.3.5	0,05	2,3	4,7	4	7	20	35	0,5	5		Δ/Δ	▲/▲	Δ/x	x/x	Δ/x
R/L105.1823.005.4.5	0,05	2,3	4,7	4	7	25	40	0,5	5		Δ/▲	▲/▲			Δ/x
R/L105.1823.005.5.5	0,05	2,3	4,7	4	7	30	45	0,5	5		Δ/Δ	▲/▲	Δ/x		x/x
R/L105.1823.1.5	0,20	2,3	4,7	4	7	10	25	0,5	5	▲/▲	▲/▲	Δ/x	▲/▲	▲/▲	▲/▲
R/L105.1823.2.5	0,20	2,3	4,7	4	7	15	30	0,5	5	▲/▲	▲/▲		▲/▲	▲/▲	▲/▲
R/L105.1823.3.5	0,20	2,3	4,7	4	7	20	35	0,5	5	▲/▲	▲/▲	Δ/x	▲/▲	▲/▲	▲/▲
R/L105.1823.4.5	0,20	2,3	4,7	4	7	25	40	0,5	5	▲/▲	▲/▲		▲/▲	▲/▲	▲/▲
R/L105.1823.5.5	0,20	2,3	4,7	4	7	30	45	0,5	5	▲/▲	▲/▲		▲/▲	▲/▲	▲/▲

▲ ab Lager / on stock Δ 4 Wochen / 4 weeks x auf Anfrage / upon request

● empfohlen / recommended

o bedingt einsetzbar / alternative recommendation

- nicht geeignet / not suitable

unbeschichtete HM-Sorten / uncoated grades

beschichtete HM-Sorten / coated grades

bestückt/Cermet / brazed/Cermet

Abmessungen in mm

Dimensions in mm

Ausführung R oder L angeben

State R or L version

Weitere Abmessungen auf Anfrage

Further sizes upon request

P	o	●	●	●	●	●	●
M	-	●	●	●	●	●	●
K	-	o	●	●	●	●	●
N	-	-	●	●	●	●	●
S	-	-	●	●	●	●	●
H	-	-	-	-	-	-	-

HM-Sorten
Carbide grades

Schneidplatte

Insert

105

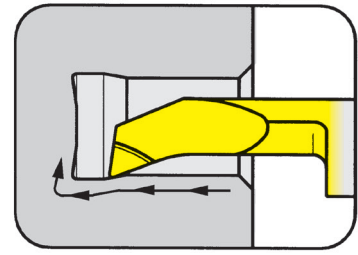

Bohrungs-Ø ab Bore Ø from 6 mm

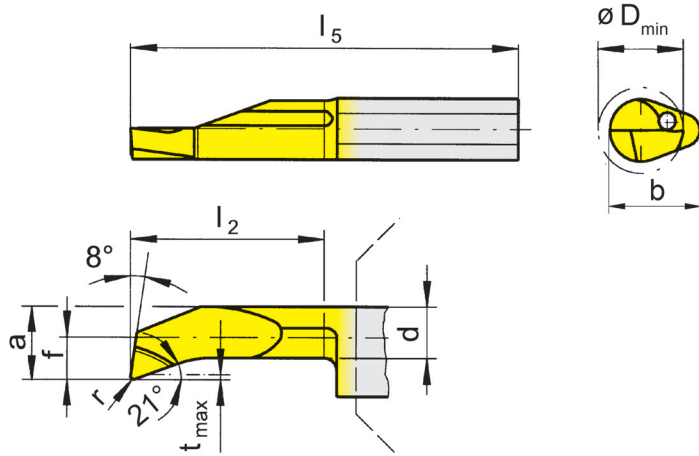

für Klemmhalter
for Toolholder

- Typ H105
Type HC105
 B105/BU105
 BKT
 IR105
 962
 AIH
 963
 N

R = rechts wie gezeichnet
R = right hand version shown

L = links spiegelbildlich
L = left hand version

Bestellnummer Part number	r	f	a	d	b	l ₂	l ₅	t _{max}	D _{min}	MG12	EG35	TF45	TH35	TI25	TN35
R/L105.1833.005.2.6	0,05	3,3	5,7	4,7	7	15	30	0,5	6,0		Δ/Δ	▲/▲	x/Δ		x/x
R/L105.1833.005.3.6	0,05	3,3	5,7	4,7	7	20	35	0,5	6,0		Δ/Δ	▲/▲			x/x
R/L105.1833.005.4.6	0,05	3,3	5,7	4,7	7	25	40	0,5	6,0		Δ/Δ	▲/Δ			x/x
R/L105.1833.005.5.6	0,05	3,3	5,7	4,7	7	30	45	0,5	6,0		Δ/Δ	▲/Δ			Δ/x
R/L105.1833.2.6	0,20	3,3	5,7	4,7	7	15	30	0,5	6,0	▲/▲	▲/▲		▲/▲	▲/▲	▲/▲
R/L105.1833.3.6	0,20	3,3	5,7	4,7	7	20	35	0,5	6,0	▲/▲	▲/▲	Δ/x	▲/▲	▲/▲	▲/▲
R/L105.1833.4.6	0,20	3,3	5,7	4,7	7	25	40	0,5	6,0	▲/▲	▲/▲		▲/▲	▲/▲	▲/▲
R/L105.1833.5.6	0,20	3,3	5,7	4,7	7	30	45	0,5	6,0	▲/▲	▲/▲		▲/▲	▲/▲	▲/▲
R/L105.1840.005.3.7	0,05	4,0	6,4	5,2	7	20	35	0,5	6,8		Δ/Δ	▲/▲			
R/L105.1840.005.4.7	0,05	4,0	6,4	5,2	7	25	40	0,5	6,8		Δ/Δ	▲/▲		x/x	
R/L105.1840.005.5.7	0,05	4,0	6,4	5,2	7	30	45	0,5	6,8		Δ/Δ	▲/▲		x/x	
R/L105.1840.3.7	0,20	4,0	6,4	5,2	7	20	35	0,5	6,8	▲/▲	▲/▲	Δ/x	▲/▲	▲/▲	▲/▲
R/L105.1840.4.7	0,20	4,0	6,4	5,2	7	25	40	0,5	6,8	▲/▲	▲/▲	Δ/x	▲/▲	▲/▲	▲/▲
R/L105.1840.5.7	0,20	4,0	6,4	5,2	7	30	45	0,5	6,8	▲/▲	▲/▲		▲/▲	▲/▲	▲/▲

- ▲ ab Lager / on stock Δ 4 Wochen / 4 weeks x auf Anfrage / upon request
- empfohlen / recommended
- o bedingt einsetzbar / alternative recommendation
- nicht geeignet / not suitable
- unbeschichtete HM-Sorten / uncoated grades
- beschichtete HM-Sorten / coated grades
- bestückt/Cermet / brazed/Cermet

P	o	●	●	●	●	●
M	-	●	●	●	●	●
K	-	o	●	●	●	●
N	-	-	●	●	●	●
S	-	-	●	●	●	●
H	-	-	-	-	-	-

Abmessungen in mm
Dimensions in mm

Ausführung R oder L angeben
State R or L version

Weitere Abmessungen auf Anfrage
Further sizes upon request

HM-Sorten
Carbide grades

Schneidplatte

Insert

105

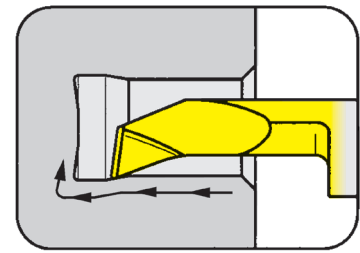

Bohrungs-Ø ab

Bore Ø from

4 mm

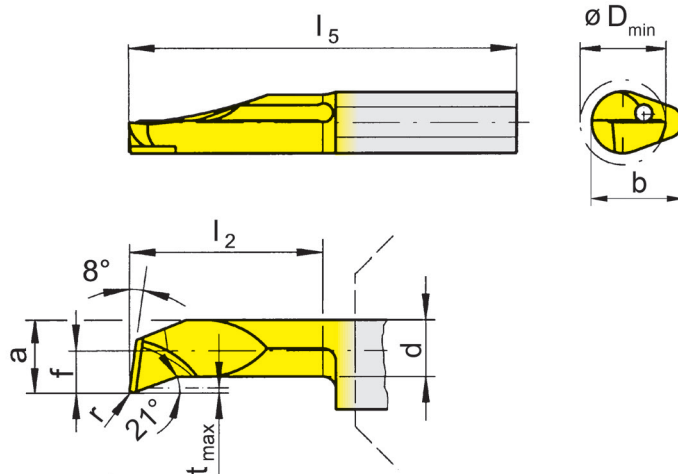

für Klemhalter
for Toolholder

Typ H105
Type HC105
B105/BU105
BKT
IR105
962
AIH
963
N

mit Spantreppe
(Geometrie H)
with chip breaker
(geometry H)

R = rechts wie gezeichnet
R = right hand version shown

L = links spiegelbildlich
L = left hand version

Bestellnummer Part number	r	f	a	d	b	l ₂	l ₅	t _{max}	D _{min}	EG35	TF45	TH35
R/L105.1819.1.H.4	0,2	1,9	3,7	2,9	7	10	25	0,3	4,0	▲/▲	▲/▲	▲/▲
R/L105.1819.2.H.4	0,2	1,9	3,7	2,9	7	15	30	0,3	4,0	▲/▲	▲/▲	▲/▲
R/L105.1819.3.H.4	0,2	1,9	3,7	2,9	7	20	35	0,3	4,0	▲/▲	▲/▲	▲/▲
R/L105.1823.1.H.5	0,2	2,3	4,7	4,0	7	10	25	0,5	5,0	▲/▲	▲/▲	▲/▲
R/L105.1823.2.H.5	0,2	2,3	4,7	4,0	7	15	30	0,5	5,0	▲/▲	▲/▲	▲/▲
R/L105.1823.3.H.5	0,2	2,3	4,7	4,0	7	20	35	0,5	5,0	▲/▲	▲/▲	▲/▲
R/L105.1823.4.H.5	0,2	2,3	4,7	4,0	7	25	40	0,5	5,0	▲/▲	▲/▲	▲/▲
R/L105.1823.5.H.5	0,2	2,3	4,7	4,0	7	30	45	0,5	5,0	▲/▲	▲/▲	▲/▲
R/L105.1833.2.H.6	0,2	3,3	5,7	4,7	7	15	30	0,5	6,0	▲/▲	▲/▲	▲/▲
R/L105.1833.3.H.6	0,2	3,3	5,7	4,7	7	20	35	0,5	6,0	▲/▲	▲/▲	▲/▲
R/L105.1833.4.H.6	0,2	3,3	5,7	4,7	7	25	40	0,5	6,0	▲/▲	▲/▲	▲/▲
R/L105.1833.5.H.6	0,2	3,3	5,7	4,7	7	30	45	0,5	6,0	▲/▲	▲/▲	▲/▲
R/L105.1840.3.H.7	0,2	4,0	6,4	5,2	7	20	35	0,5	6,8	▲/▲	▲/▲	▲/▲
R/L105.1840.4.H.7	0,2	4,0	6,4	5,2	7	25	40	0,5	6,8	▲/▲	▲/▲	▲/▲
R/L105.1840.5.H.7	0,2	4,0	6,4	5,2	7	30	45	0,5	6,8	▲/▲	▲/▲	▲/▲

▲ ab Lager / on stock Δ 4 Wochen / 4 weeks x auf Anfrage / upon request

● empfohlen / recommended

o bedingt einsetzbar / alternative recommendation

- nicht geeignet / not suitable

■ unbeschichtete HM-Sorten / uncoated grades

■ beschichtete HM-Sorten / coated grades

■ bestückt/Cermet / brazed/Cermet

Abmessungen in mm

Dimensions in mm

Ausführung R oder L angeben

State R or L version

Weitere Abmessungen auf Anfrage

Further sizes upon request

P	●	●	●
M	●	●	●
K	○	●	●
N	-	●	●
S	-	●	●
H	-	-	-

HM-Sorten
Carbide grades

Schneidplatte

Insert

105

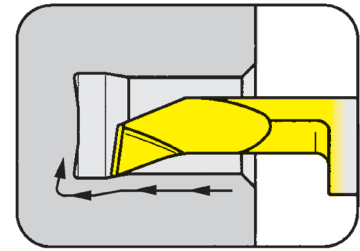

Bohrungs-Ø ab Bore Ø from 4 mm

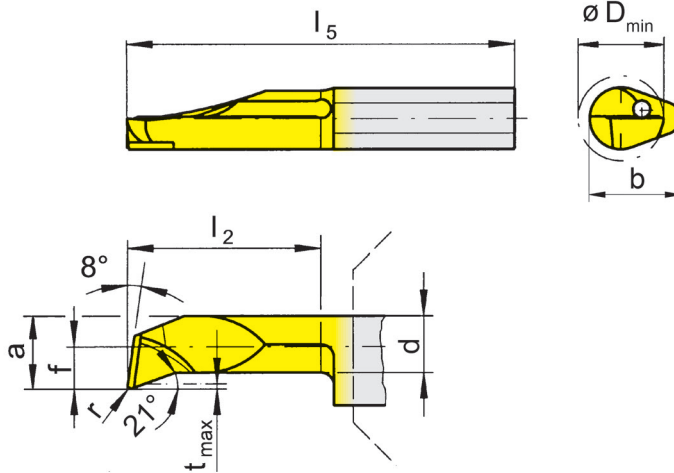

für Klemhalter
for Toolholder

- Typ H105
Type HC105
 B105/BU105
 BKT
 IR105
 962
 AIH
 963
 N

verlängerte Spantreppe
(Geometrie HV)
extended chip breaker
(geometry HV)

R = rechts wie gezeichnet
R = right hand version shown

L = links spiegelbildlich
L = left hand version

Bestellnummer Part number	r	f	a	d	b	l ₂	l ₅	t _{max}	D _{min}	EG35	TH35
R/L105.1819.1.HV4	0,2	1,9	3,7	2,9	7	10	25	0,3	4,0	Δ/Δ	▲/Δ
R/L105.1819.2.HV4	0,2	1,9	3,7	2,9	7	15	30	0,3	4,0	Δ/Δ	▲/▲
R/L105.1819.3.HV4	0,2	1,9	3,7	2,9	7	20	35	0,3	4,0	Δ/Δ	▲/▲
R/L105.1823.1.HV5	0,2	2,3	4,7	4,0	7	10	25	0,5	5,0	Δ/Δ	▲/▲
R/L105.1823.2.HV5	0,2	2,3	4,7	4,0	7	15	30	0,5	5,0	Δ/Δ	▲/▲
R/L105.1823.3.HV5	0,2	2,3	4,7	4,0	7	20	35	0,5	5,0	Δ/Δ	▲/▲
R/L105.1823.4.HV5	0,2	2,3	4,7	4,0	7	25	40	0,5	5,0	Δ/Δ	▲/Δ
R/L105.1823.5.HV5	0,2	2,3	4,7	4,0	7	30	45	0,5	5,0	Δ/Δ	▲/Δ
R/L105.1833.2.HV6	0,2	3,3	5,7	4,7	7	15	30	0,5	6,0	Δ/Δ	▲/▲
R/L105.1833.3.HV6	0,2	3,3	5,7	4,7	7	20	35	0,5	6,0	Δ/Δ	▲/Δ
R/L105.1833.4.HV6	0,2	3,3	5,7	4,7	7	25	40	0,5	6,0	Δ/▲	▲/▲
R/L105.1833.5.HV6	0,2	3,3	5,7	4,7	7	30	45	0,5	6,0	Δ/Δ	▲/Δ
R/L105.1840.2.HV7	0,2	4,0	6,4	5,2	7	15	30	0,5	6,8	Δ/Δ	▲/▲
R/L105.1840.3.HV7	0,2	4,0	6,4	5,2	7	20	35	0,5	6,8	Δ/Δ	▲/Δ
R/L105.1840.4.HV7	0,2	4,0	6,4	5,2	7	25	40	0,5	6,8	▲/Δ	▲/Δ
R/L105.1840.5.HV7	0,2	4,0	6,4	5,2	7	30	45	0,5	6,8	Δ/Δ	▲/Δ

- ▲ ab Lager / on stock Δ 4 Wochen / 4 weeks x auf Anfrage / upon request
- empfohlen / recommended
- o bedingt einsetzbar / alternative recommendation
- nicht geeignet / not suitable
- unbeschichtete HM-Sorten / uncoated grades
- beschichtete HM-Sorten / coated grades
- bestückt/Cermet / brazed/Cermet

Abmessungen in mm
Dimensions in mm
Ausführung R oder L angeben
State R or L version

Weitere Abmessungen auf Anfrage
Further sizes upon request

P	•	•
M	•	•
K	o	•
N	-	•
S	-	•
H	-	-

HM-Sorten
Carbide grades

Schneidplatte

105

Insert

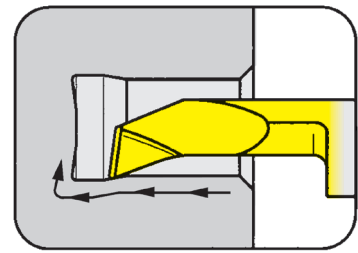

Bohrungs-Ø ab

Bore Ø from

4 mm

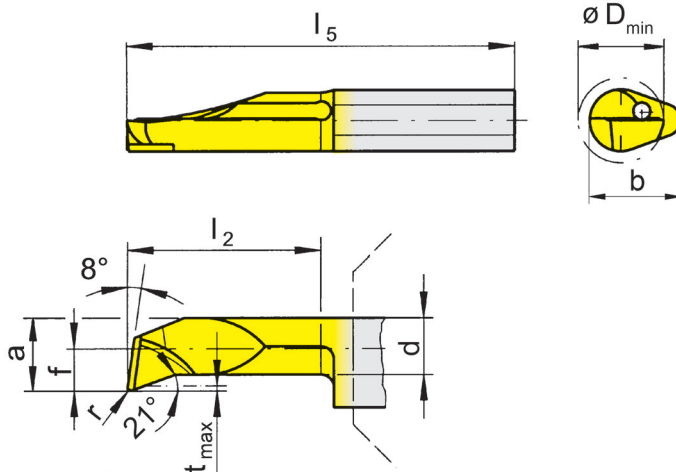

für Klemhalter
for Toolholder

Typ H105
Type HC105
B105/BU105
BKT
IR105
962
AIH
963
N

verlängerte Spantreppe
(Geometrie HV)
extended chip breaker
(geometry HV)

R = rechts wie gezeichnet
R = right hand version shown

L = links spiegelbildlich
L = left hand version

Bestellnummer Part number	r	f	a	d	b	l ₂	l ₅	t _{max}	D _{min}	EG35	TH35
R/L105.1819.04.1.HV4	0,4	1,9	3,7	2,9	7	10	25	0,3	4,0	Δ/Δ	▲/▲
R/L105.1819.04.2.HV4	0,4	1,9	3,7	2,9	7	15	30	0,3	4,0	▲/Δ	▲/Δ
R/L105.1819.04.3.HV4	0,4	1,9	3,7	2,9	7	20	35	0,3	4,0	Δ/Δ	▲/Δ
R/L105.1823.04.1.HV5	0,4	2,3	4,7	4,0	7	10	25	0,5	5,0	Δ/Δ	▲/▲
R/L105.1823.04.2.HV5	0,4	2,3	4,7	4,0	7	15	30	0,5	5,0	Δ/Δ	▲/Δ
R/L105.1823.04.3.HV5	0,4	2,3	4,7	4,0	7	20	35	0,5	5,0	Δ/Δ	▲/Δ
R/L105.1823.04.4.HV5	0,4	2,3	4,7	4,0	7	25	40	0,5	5,0	Δ/Δ	▲/Δ
R/L105.1823.04.5.HV5	0,4	2,3	4,7	4,0	7	30	45	0,5	5,0	Δ/Δ	▲/▲
R/L105.1833.04.2.HV6	0,4	3,3	5,7	4,7	7	15	30	0,5	6,0	Δ/Δ	▲/▲
R/L105.1833.04.3.HV6	0,4	3,3	5,7	4,7	7	20	35	0,5	6,0	Δ/Δ	▲/Δ
R/L105.1833.04.4.HV6	0,4	3,3	5,7	4,7	7	25	40	0,5	6,0	Δ/Δ	▲/Δ
R/L105.1833.04.5.HV6	0,4	3,3	5,7	4,7	7	30	45	0,5	6,0	Δ/Δ	▲/Δ
R/L105.1840.04.2.HV7	0,4	4,0	6,4	5,2	7	15	30	0,5	6,8	Δ/Δ	▲/▲
R/L105.1840.04.3.HV7	0,4	4,0	6,4	5,2	7	20	35	0,5	6,8	Δ/Δ	▲/▲
R/L105.1840.04.4.HV7	0,4	4,0	6,4	5,2	7	25	40	0,5	6,8	Δ/Δ	▲/Δ
R/L105.1840.04.5.HV7	0,4	4,0	6,4	5,2	7	30	45	0,5	6,8	Δ/Δ	▲/Δ

▲ ab Lager / on stock Δ 4 Wochen / 4 weeks x auf Anfrage / upon request

● empfohlen / recommended

o bedingt einsetzbar / alternative recommendation

- nicht geeignet / not suitable

■ unbeschichtete HM-Sorten / uncoated grades

■ beschichtete HM-Sorten / coated grades

■ bestückt/Cermet / brazed/Cermet

Abmessungen in mm

Dimensions in mm

Ausführung R oder L angeben

State R or L version

Weitere Abmessungen auf Anfrage

Further sizes upon request

HM-Sorten

Carbide grades

P	•	•
M	•	•
K	o	•
N	-	•
S	-	•
H	-	-

Schneidplatte

Insert

105

verstärkte Ausführung
reinforced version

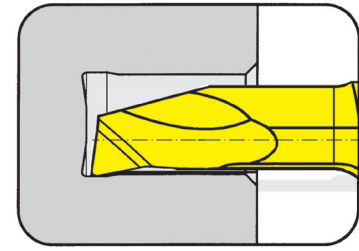

Bohrungs-Ø ab	Bore Ø from	4 mm
---------------	-------------	------

für Klemmhalter
for Toolholder

Typ H105
Type HC105
B105/BU105
BKT
IR105
962
AIH
963
N

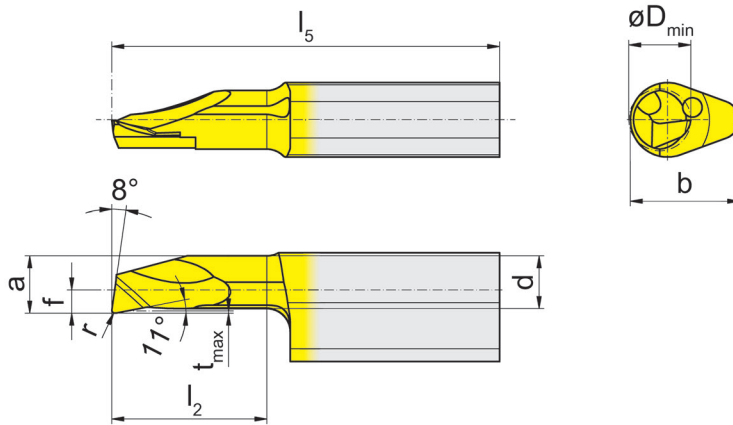

R = rechts wie gezeichnet
R = right hand version shown

L = links spiegelbildlich
L = left hand version

Bestellnummer Part number	r	f	a	d	b	l ₂	l ₅	t _{max}	D _{min}	EG35	TH35
R/L105.1019.005.1.4	0,05	1,5	3,7	3,4	7	10	25	0,15	4	▲/▲	▲/▲
R/L105.1019.005.2.4	0,05	1,5	3,7	3,4	7	15	30	0,15	4	▲/▲	▲/▲
R/L105.1019.005.3.4	0,05	1,5	3,7	3,4	7	20	35	0,15	4	▲/▲	▲/▲
R/L105.1019.005.4.4	0,05	1,5	3,7	3,4	7	25	40	0,15	4	▲/▲	▲/▲
R/L105.1019.1.4	0,20	1,5	3,7	3,4	7	10	25	0,15	4	▲/▲	▲/▲
R/L105.1019.2.4	0,20	1,5	3,7	3,4	7	15	30	0,15	4	▲/▲	▲/▲
R/L105.1019.3.4	0,20	1,5	3,7	3,4	7	20	35	0,15	4	▲/▲	▲/▲
R/L105.1019.4.4	0,20	1,5	3,7	3,4	7	25	40	0,15	4	▲/▲	▲/▲

▲ ab Lager / on stock Δ 4 Wochen / 4 weeks x auf Anfrage / upon request

● empfohlen / recommended

o bedingt einsetzbar / alternative recommendation

- nicht geeignet / not suitable

■ unbeschichtete HM-Sorten / uncoated grades

■ beschichtete HM-Sorten / coated grades

■ bestückt/Cermet / brazed/Cermet

Abmessungen in mm

Dimensions in mm

Ausführung R oder L angeben

State R or L version

Weitere Abmessungen auf Anfrage

Further sizes upon request

P	●	●
M	●	●
K	○	●
N	-	●
S	-	●
H	-	-

HM-Sorten
Carbide grades

Schneidplatte

Insert

105

verstärkte Ausführung
reinforced version

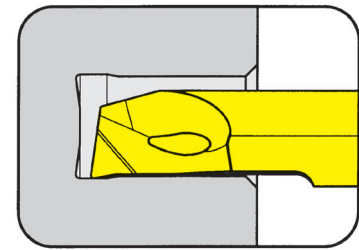

Bohrungs-Ø ab

Bore Ø from

5 mm

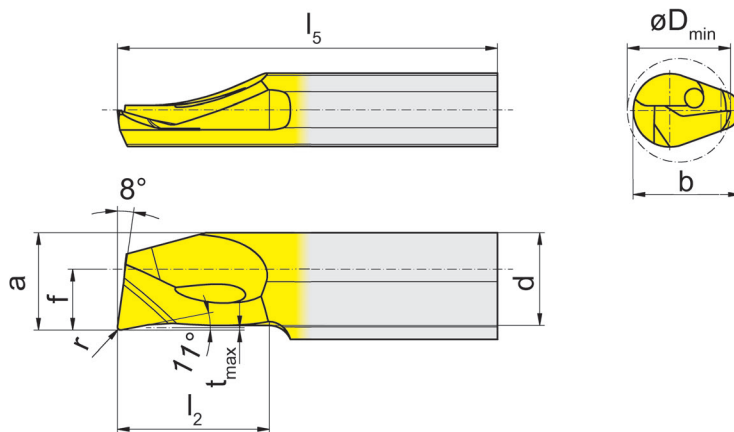

für Klemmhalter
for Toolholder

Typ H105
Type HC105
B105/BU105
BKT
IR105
962
AIH
963
N

R = rechts wie gezeichnet
R = right hand version shown

L = links spiegelbildlich
L = left hand version

Bestellnummer Part number	r	f	a	d	b	l_2	l_5	t_{max}	D_{min}	EG35	TH35
R/L105.1023.005.1.5	0,05	2,8	4,7	4,4	7	10	25	0,15	5	▲/Δ	▲/▲
R/L105.1023.005.2.5	0,05	2,8	4,7	4,4	7	15	30	0,15	5	Δ/Δ	▲/Δ
R/L105.1023.005.3.5	0,05	2,8	4,7	4,4	7	20	35	0,15	5	Δ/Δ	▲/▲
R/L105.1023.005.4.5	0,05	2,8	4,7	4,4	7	25	40	0,15	5	Δ/Δ	▲/▲
R/L105.1023.005.5.5	0,05	2,8	4,7	4,4	7	30	45	0,15	5	Δ/Δ	▲/▲
R/L105.1023.005.6.5	0,05	2,8	4,7	4,4	7	35	50	0,15	5	Δ/Δ	▲/▲
R/L105.1023.1.5	0,20	2,8	4,7	4,4	7	10	25	0,15	5	Δ/Δ	▲/▲
R/L105.1023.2.5	0,20	2,8	4,7	4,4	7	15	30	0,15	5	Δ/Δ	▲/▲
R/L105.1023.3.5	0,20	2,8	4,7	4,4	7	20	35	0,15	5	Δ/Δ	▲/▲
R/L105.1023.4.5	0,20	2,8	4,7	4,4	7	25	40	0,15	5	Δ/Δ	▲/▲
R/L105.1023.5.5	0,20	2,8	4,7	4,4	7	30	45	0,15	5	Δ/Δ	▲/▲
R/L105.1023.6.5	0,20	2,8	4,7	4,4	7	35	50	0,15	5	Δ/Δ	▲/▲

▲ ab Lager / on stock Δ 4 Wochen / 4 weeks x auf Anfrage / upon request

● empfohlen / recommended

o bedingt einsetzbar / alternative recommendation

- nicht geeignet / not suitable

■ unbeschichtete HM-Sorten / uncoated grades

■ beschichtete HM-Sorten / coated grades

■ bestückt/Cermet / brazed/Cermet

Abmessungen in mm

Dimensions in mm

Ausführung R oder L angeben

State R or L version

Weitere Abmessungen auf Anfrage

Further sizes upon request

P	•	•
M	•	•
K	o	•
N	-	•
S	-	•
H	-	-

HM-Sorten
Carbide grades

Schneidplatte

Insert

105

verstärkte Ausführung
reinforced version

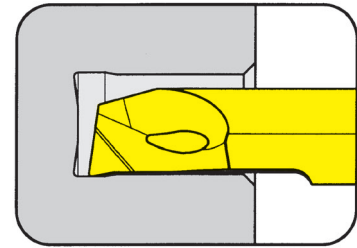

Bohrungs-Ø ab	Bore Ø from	6 mm
---------------	-------------	------

für Klemmhalter
for Toolholder

Typ H105
Type HC105
B105/BU105
BKT
IR105
962
AIH
963
N

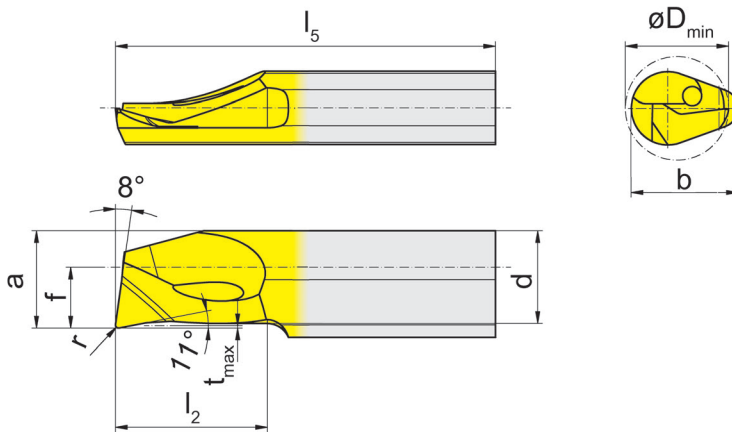

R = rechts wie gezeichnet
R = right hand version shown

L = links spiegelbildlich
L = left hand version

Bestellnummer Part number	r	f	a	d	b	l ₂	l ₅	t _{max}	D _{min}	EG35	TH35
R/L105.1033.005.1.6	0,05	3,3	5,7	5,4	7	10	25	0,15	6	Δ/Δ	▲/▲
R/L105.1033.005.2.6	0,05	3,3	5,7	5,4	7	15	30	0,15	6	Δ/Δ	▲/▲
R/L105.1033.005.3.6	0,05	3,3	5,7	5,4	7	20	35	0,15	6	Δ/Δ	▲/▲
R/L105.1033.005.4.6	0,05	3,3	5,7	5,4	7	25	40	0,15	6	Δ/Δ	▲/Δ
R/L105.1033.005.5.6	0,05	3,3	5,7	5,4	7	30	45	0,15	6	Δ/Δ	▲/▲
R/L105.1033.005.6.6	0,05	3,3	5,7	5,4	7	35	50	0,15	6	Δ/Δ	▲/▲
R/L105.1033.1.6	0,20	3,3	5,7	5,4	7	10	25	0,15	6	▲/Δ	▲/▲
R/L105.1033.2.6	0,20	3,3	5,7	5,4	7	15	30	0,15	6	▲/Δ	▲/▲
R/L105.1033.3.6	0,20	3,3	5,7	5,4	7	20	35	0,15	6	▲/Δ	▲/▲
R/L105.1033.4.6	0,20	3,3	5,7	5,4	7	25	40	0,15	6	Δ/Δ	▲/▲
R/L105.1033.5.6	0,20	3,3	5,7	5,4	7	30	45	0,15	6	Δ/Δ	▲/▲
R/L105.1033.6.6	0,20	3,3	5,7	5,4	7	35	50	0,15	6	▲/Δ	▲/▲

▲ ab Lager / on stock Δ 4 Wochen / 4 weeks x auf Anfrage / upon request

● empfohlen / recommended

o bedingt einsetzbar / alternative recommendation

- nicht geeignet / not suitable

unbeschichtete HM-Sorten / uncoated grades

beschichtete HM-Sorten / coated grades

bestückt/Cermet / brazed/Cermet

Abmessungen in mm

Dimensions in mm

Ausführung R oder L angeben

State R or L version

Weitere Abmessungen auf Anfrage

Further sizes upon request

P	•	•
M	•	•
K	o	•
N	-	•
S	-	•
H	-	-

HM-Sorten
Carbide grades

Schneidplatte

105

Insert

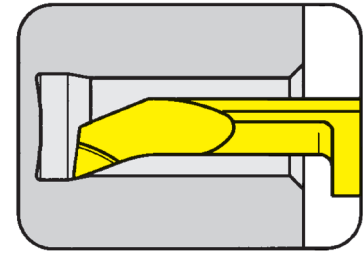

Bohrungs-Ø ab

Bore Ø from

3 mm

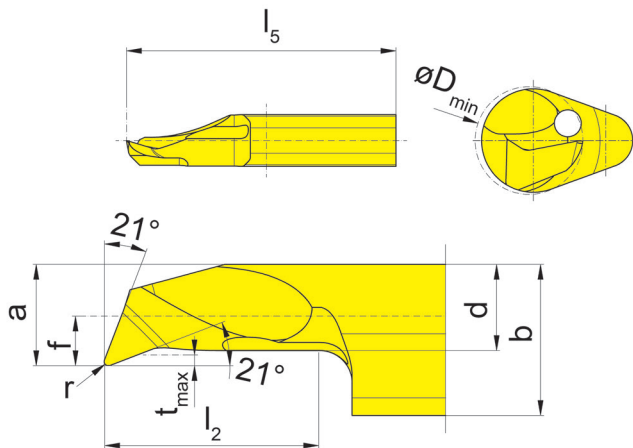

für Klemmhalter
for Toolholder

Typ H105
Type HC105
B105/BU105
BKT
IR105
962
AIH
963
N

R = rechts wie gezeichnet
R = right hand version shown

L = links spiegelbildlich
L = left hand version

Bestellnummer Part number	r	f	a	d	b	l ₂	l ₅	t _{max}	D _{min}	EG35
R/L105.2113.1.3	0,10	1,3	2,6	2,3	5,9	10	25	0,15	3	▲▲
R/L105.2113.2.3	0,10	1,3	2,6	2,3	5,9	15	30	0,15	3	▲▲
R/L105.2113.3.3	0,10	1,3	2,6	2,3	5,9	20	35	0,15	3	▲▲
R/L105.2119.1.4	0,15	1,9	3,7	3,0	6,4	10	25	0,30	4	▲▲
R/L105.2119.2.4	0,15	1,9	3,7	3,0	6,4	15	30	0,30	4	▲▲
R/L105.2119.3.4	0,15	1,9	3,7	3,0	6,4	20	35	0,30	4	▲▲
R/L105.2119.4.4	0,15	1,9	3,7	3,0	6,4	25	40	0,30	4	△△
R/L105.2123.1.5	0,20	2,3	4,7	4,0	7,0	10	25	0,50	5	△△
R/L105.2123.2.5	0,20	2,3	4,7	4,0	7,0	15	30	0,50	5	▲▲
R/L105.2123.3.5	0,20	2,3	4,7	4,0	7,0	20	35	0,50	5	▲▲
R/L105.2123.4.5	0,20	2,3	4,7	4,0	7,0	25	40	0,50	5	△△
R/L105.2123.5.5	0,20	2,3	4,7	4,0	7,0	30	45	0,50	5	△△
R/L105.2123.6.5	0,20	2,3	4,7	4,0	7,0	35	50	0,50	5	△△

▲ ab Lager / on stock Δ 4 Wochen / 4 weeks x auf Anfrage / upon request

● empfohlen / recommended

o bedingt einsetzbar / alternative recommendation

- nicht geeignet / not suitable

■ unbeschichtete HM-Sorten / uncoated grades

■ beschichtete HM-Sorten / coated grades

■ bestückt/Cermet / brazed/Cermet

Abmessungen in mm

Dimensions in mm

Weitere Abmessungen auf Anfrage

Further sizes upon request

P	•
M	•
K	o
N	-
S	-
H	-

HM-Sorten
Carbide grades

Schneidplatte

Insert

105

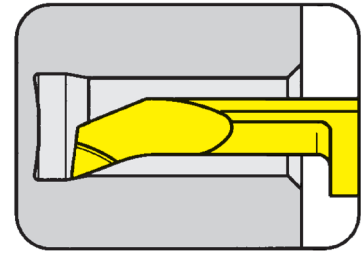

Bohrungs-Ø ab Bore Ø from 6 mm

für Klemhalter
for Toolholder

- Typ H105
Type HC105
 B105/BU105
 BKT
 IR105
 962
 AIH
 963
 N

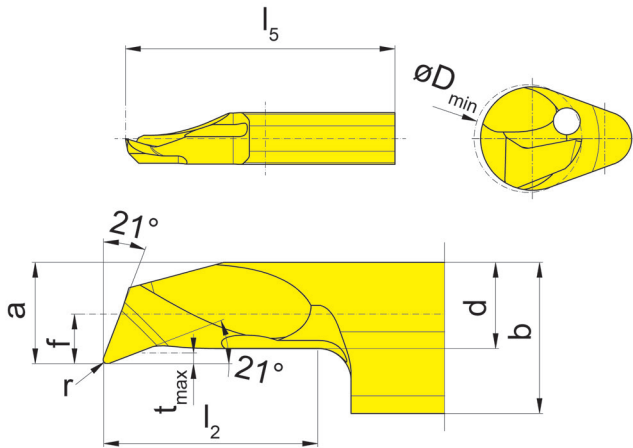

R = rechts wie gezeichnet
R = right hand version shown

L = links spiegelbildlich
L = left hand version

Bestellnummer Part number	r	f	a	d	b	l ₂	l ₅	t _{max}	D _{min}	EG35
R/L105.2133.1.6	0,2	3,3	5,7	4,7	7	10	25	0,5	6,0	▲/▲
R/L105.2133.2.6	0,2	3,3	5,7	4,7	7	15	30	0,5	6,0	▲/▲
R/L105.2133.3.6	0,2	3,3	5,7	4,7	7	20	35	0,5	6,0	▲/▲
R/L105.2133.4.6	0,2	3,3	5,7	4,7	7	25	40	0,5	6,0	△/△
R/L105.2133.5.6	0,2	3,3	5,7	4,7	7	30	45	0,5	6,0	△/△
R/L105.2133.6.6	0,2	3,3	5,7	4,7	7	35	50	0,5	6,0	△/△
R/L105.2140.1.7	0,2	4,0	6,4	5,2	7	10	25	0,5	6,8	▲/▲
R/L105.2140.2.7	0,2	4,0	6,4	5,2	7	15	30	0,5	6,8	▲/▲
R/L105.2140.3.7	0,2	4,0	6,4	5,2	7	20	35	0,5	6,8	▲/▲
R/L105.2140.4.7	0,2	4,0	6,4	5,2	7	25	40	0,5	6,8	△/△
R/L105.2140.5.7	0,2	4,0	6,4	5,2	7	30	45	0,5	6,8	△/△
R/L105.2140.6.7	0,2	4,0	6,4	5,2	7	35	50	0,5	6,8	△/△

- ▲ ab Lager / on stock Δ 4 Wochen / 4 weeks x auf Anfrage / upon request
- empfohlen / recommended
- o bedingt einsetzbar / alternative recommendation
- nicht geeignet / not suitable
- unbeschichtete HM-Sorten / uncoated grades
- beschichtete HM-Sorten / coated grades
- bestückt/Cermet / brazed/Cermet

P	•
M	•
K	o
N	-
S	-
H	-

Abmessungen in mm
Dimensions in mm

HM-Sorten
Carbide grades

Weitere Abmessungen auf Anfrage
Further sizes upon request

Schneidplatte

Insert

105

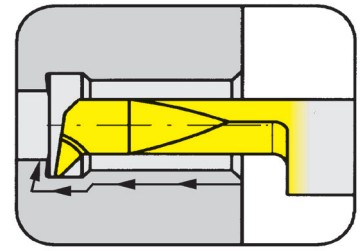

Bohrungs-Ø ab	Bore Ø from	2 mm
---------------	-------------	------

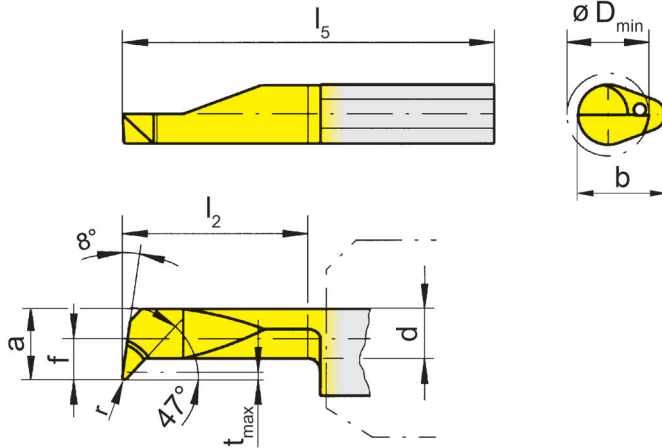

für Klemmhalter
for Toolholder

- Typ H105
Type HC105
B105/BU105
BKT
IR105
962
AIH
963
N

R = rechts wie gezeichnet
R = right hand version shown

L = links spiegelbildlich
L = left hand version

Bestellnummer Part number	r	f	a	d	b	l ₂	l ₅	t _{max}	D _{min}	MG12	AN25	EG35	ES15	TF45	TH35	TI25	TN35
R105.4715.005.1.2	0,05	1,5	1,9	1,45	5,9	9	25	0,3	2		Δ	▲	▲				
R105.4715.005.2.2	0,05	1,5	1,9	1,45	5,9	12	30	0,3	2		Δ	Δ	Δ				
R105.4713.005.1.3	0,05	1,3	2,6	2,00	5,9	10	25	0,4	3	▲	Δ	▲	▲				
R105.4713.005.2.3	0,05	1,3	2,6	2,00	5,9	15	30	0,4	3		Δ	Δ	▲				
R/L105.4719.1.4	0,15	1,9	3,7	2,90	6,4	10	25	0,6	4			▲/▲			▲/▲		
R/L105.4719.3.4	0,15	1,9	3,7	2,90	6,4	20	35	0,6	4	Δ/x		▲/▲		x/x	▲/▲	▲/▲	▲/▲
R/L105.4723.2.5	0,15	2,3	4,7	3,70	7,0	15	30	0,8	5			▲/Δ			▲/▲		Δ/x
R/L105.4723.4.5	0,15	2,3	4,7	3,70	7,0	25	40	0,8	5			▲/▲			▲/▲	▲/▲	▲/▲
R/L105.4733.3.6	0,15	3,3	5,7	3,70	7,0	20	35	1,8	6			▲/Δ			▲/▲		
R/L105.4733.5.6	0,15	3,3	5,7	3,70	7,0	30	45	1,8	6	Δ/x		▲/▲			▲/▲	Δ/Δ	▲/▲

- ▲ ab Lager / on stock Δ 4 Wochen / 4 weeks x auf Anfrage / upon request
- empfohlen / recommended
- o bedingt einsetzbar / alternative recommendation
- nicht geeignet / not suitable
- unbeschichtete HM-Sorten / uncoated grades
- beschichtete HM-Sorten / coated grades
- bestückt/Cermet / brazed/Cermet

Abmessungen in mm
Dimensions in mm

Ausführung R oder L angeben
State R or L version

Weitere Abmessungen auf Anfrage
Further sizes upon request

P	o	●	●	●	●	●	●	●	●	●	●	●	●	●	●	●	●
M	-	o	●	o	●	●	●	●	●	●	●	●	●	●	●	●	●
K	-	-	o	●	●	●	●	●	●	●	●	●	●	●	●	●	●
N	-	-	-	-	●	●	●	●	●	●	●	●	●	●	●	●	●
S	-	-	-	-	●	●	●	●	●	●	●	●	●	●	●	●	●
H	-	-	-	-	-	-	-	-	-	-	-	-	-	-	-	-	-

HM-Sorten
Carbide grades

Schneidplatte

Insert

105

verstärkte Ausführung
reinforced version

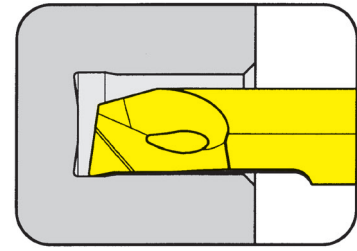

Bohrungs-Ø ab	Bore Ø from	6,8 mm
---------------	-------------	--------

für Klemmhalter
for Toolholder

Typ H105
Type HC105
B105/BU105
BKT
IR105
962
AIH
963
N

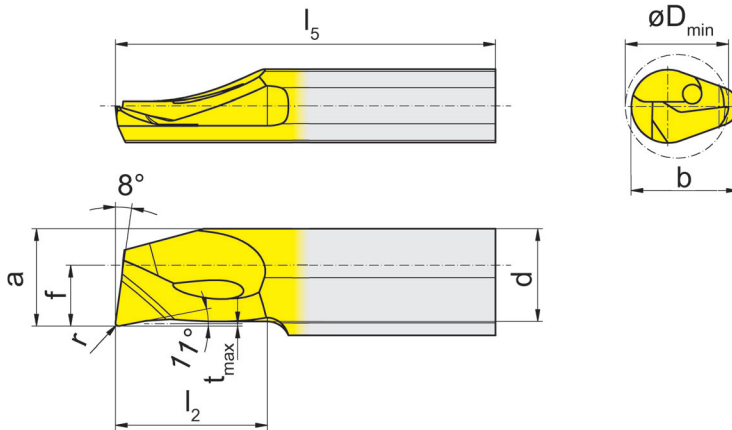

R = rechts wie gezeichnet
R = right hand version shown

L = links spiegelbildlich
L = left hand version

Bestellnummer Part number	r	f	a	d	b	l ₂	l ₅	t _{max}	D _{min}	EG35	TH35
R/L105.1040.1.7	0,2	4	6,4	6,1	7	10	25	0,15	6,8	▲/Δ	▲/▲
R/L105.1040.2.7	0,2	4	6,4	6,1	7	15	30	0,15	6,8	▲/Δ	▲/▲
R/L105.1040.3.7	0,2	4	6,4	6,1	7	20	35	0,15	6,8	▲/Δ	▲/▲
R/L105.1040.4.7	0,2	4	6,4	6,1	7	25	40	0,15	6,8	Δ/Δ	▲/▲
R/L105.1040.5.7	0,2	4	6,4	6,1	7	30	45	0,15	6,8	Δ/Δ	▲/▲
R/L105.1040.6.7	0,2	4	6,4	6,1	7	35	50	0,15	6,8	Δ/Δ	▲/▲

▲ ab Lager / on stock Δ 4 Wochen / 4 weeks x auf Anfrage / upon request

● empfohlen / recommended

o bedingt einsetzbar / alternative recommendation

- nicht geeignet / not suitable

■ unbeschichtete HM-Sorten / uncoated grades

■ beschichtete HM-Sorten / coated grades

■ bestückt/Cermet / brazed/Cermet

Abmessungen in mm

Dimensions in mm

Ausführung R oder L angeben

State R or L version

Weitere Abmessungen auf Anfrage

Further sizes upon request

P	●	●
M	●	●
K	○	●
N	-	●
S	-	●
H	-	-

HM-Sorten
Carbide grades

Schneidplatte

105

Insert

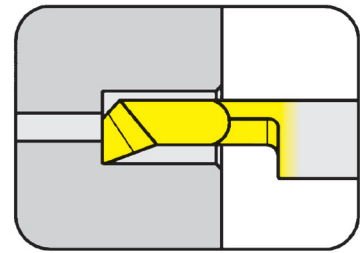

Bohrungs-Ø ab

Bore Ø from

3 mm

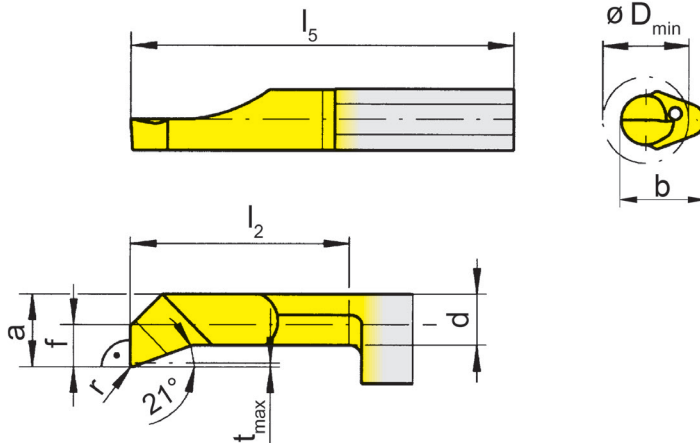

für Klemhalter
for Toolholder

Typ H105
Type HC105
B105/BU105
BKT
IR105
962
AIH
963
N

R = rechts wie gezeichnet
R = right hand version shown

L = links spiegelbildlich
L = left hand version

Bestellnummer Part number	r	f	a	d	b	l ₂	l ₅	t _{max}	D _{min}	HM-Sorten Carbide grades				
										EG35	TH35	TI25	TN35	
R/L105.9013.01.1.3	0,1	1,3	2,6	2,3	5,9	10	25	0,15	3	▲/▲	▲/▲			
R/L105.9013.01.2.3	0,1	1,3	2,6	2,3	5,9	15	30	0,15	3	▲/▲	▲/▲			
R/L105.9013.01.3.3	0,1	1,3	2,6	2,3	5,9	20	35	0,15	3	▲/▲	▲/▲			
R/L105.9013.1.3	0,2	1,3	2,6	2,3	5,9	10	25	0,15	3	▲/▲			▲/▲	
R/L105.9013.2.3	0,2	1,3	2,6	2,3	5,9	15	30	0,15	3	▲/▲			▲/▲	
R/L105.9019.01.1.4	0,1	1,9	3,7	2,9	6,4	10	25	0,30	4	▲/▲	▲/▲			
R/L105.9019.01.2.4	0,1	1,9	3,7	2,9	6,4	15	30	0,30	4	▲/▲	▲/▲			
R/L105.9019.01.3.4	0,1	1,9	3,7	2,9	6,4	20	35	0,30	4	▲/▲	▲/▲			
R/L105.9019.1.4	0,2	1,9	3,7	2,9	6,4	10	25	0,30	4	▲/▲			▲/▲	
R/L105.9019.2.4	0,2	1,9	3,7	2,9	6,4	15	30	0,30	4	▲/▲		▲/x	▲/▲	
										P	•	•	•	•
										M	•	•	•	•
										K	○	•	•	•
										N	-	•	•	•
										S	-	•	•	•
										H	-	-	-	-

▲ ab Lager / on stock Δ 4 Wochen / 4 weeks x auf Anfrage / upon request

• empfohlen / recommended

o bedingt einsetzbar / alternative recommendation

- nicht geeignet / not suitable

■ unbeschichtete HM-Sorten / uncoated grades

■ beschichtete HM-Sorten / coated grades

■ bestückt/Cermet / brazed/Cermet

Abmessungen in mm

Dimensions in mm

Ausführung R oder L angeben

State R or L version

Weitere Abmessungen auf Anfrage

Further sizes upon request

HM-Sorten
Carbide grades

Schneidplatte

Insert

105

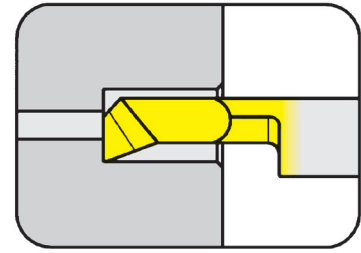

Bohrungs-Ø ab Bore Ø from 5 mm

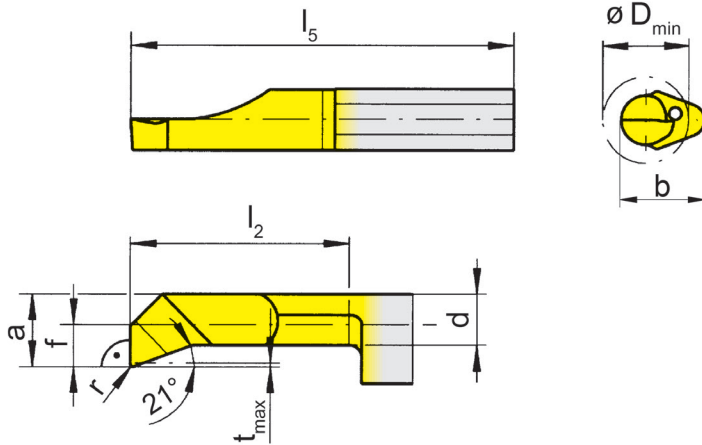

für Klemhalter
for Toolholder

- Typ H105
Type HC105
 B105/BU105
 BKT
 IR105
 962
 AIH
 963
 N

R = rechts wie gezeichnet
R = right hand version shown

L = links spiegelbildlich
L = left hand version

Bestellnummer Part number	r	f	a	d	b	l ₂	l ₅	t _{max}	D _{min}	EG35	TH35	TN35
R/L105.9023.01.1.5	0,1	2,3	4,7	4,0	7	10	25	0,5	5	▲/▲	▲/▲	
R/L105.9023.01.2.5	0,1	2,3	4,7	4,0	7	15	30	0,5	5	▲/▲	▲/▲	
R/L105.9023.01.3.5	0,1	2,3	4,7	4,0	7	20	35	0,5	5	▲/▲	▲/▲	
R/L105.9023.01.4.5	0,1	2,3	4,7	4,0	7	25	40	0,5	5	▲/▲	▲/▲	
R/L105.9023.1.5	0,2	2,3	4,7	4,0	7	10	25	0,5	5	▲/▲	▲/x	▲/▲
R/L105.9023.2.5	0,2	2,3	4,7	4,0	7	15	30	0,5	5	▲/▲	▲/x	▲/▲
R/L105.9023.3.5	0,2	2,3	4,7	4,0	7	20	35	0,5	5	▲/▲		▲/▲
R/L105.9033.1.6	0,2	3,3	5,7	4,7	7	10	25	0,5	6	▲/▲	▲/x	
R/L105.9033.2.6	0,2	3,3	5,7	4,7	7	15	30	0,5	6	▲/▲	▲/▲	
R/L105.9033.3.6	0,2	3,3	5,7	4,7	7	20	35	0,5	6	▲/▲	▲/▲	
R/L105.9033.4.6	0,2	3,3	5,7	4,7	7	25	40	0,5	6	▲/▲	▲/▲	
R/L105.9033.5.6	0,2	3,3	5,7	4,7	7	30	45	0,5	6	▲/▲	▲/▲	

- ▲ ab Lager / on stock Δ 4 Wochen / 4 weeks x auf Anfrage / upon request
- empfohlen / recommended
- o bedingt einsetzbar / alternative recommendation
- nicht geeignet / not suitable
- unbeschichtete HM-Sorten / uncoated grades
- beschichtete HM-Sorten / coated grades
- bestückt/Cermet / brazed/Cermet

P	●	●	●
M	●	●	●
K	o	●	●
N	-	●	●
S	-	●	●
H	-	-	-

HM-Sorten
Carbide grades

Abmessungen in mm
Dimensions in mm

Ausführung R oder L angeben
State R or L version

Weitere Abmessungen auf Anfrage
Further sizes upon request

Einstecken (innen)

Grooving (internal)



Schneidplatte

Insert

105

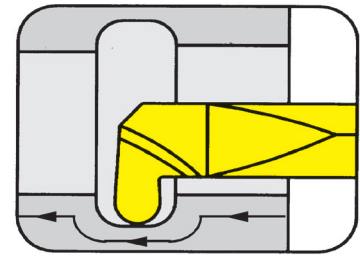

Bohrungs-Ø ab
Vollradius

Bore Ø from
Full radius

4 mm
0,25-1 mm

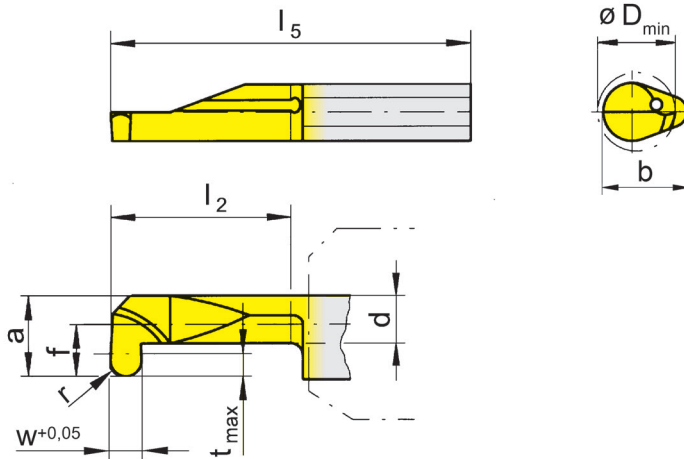

für Klemhalter
for Toolholder

Typ H105
Type HC105
B105/BU105
BKT
IR105
962
AIH
963
N

Vollradius
Full radius

R = rechts wie gezeichnet
R = right hand version shown

L = links spiegelbildlich
L = left hand version

Bestellnummer Part number	w	r	f	a	d	b	l_2	l_5	t_{max}	D_{min}	AN25	EG35	ES15	TF45	TH35	TN35
R105.0025.2.3	0,5	0,25	1,4	2,7	1,9	5,9	15	30	0,6	3	Δ	Δ	Δ			
R/L105.0005.1.4	1,0	0,50	1,9	3,7	2,7	6,4	10	25	0,8	4		Δ/▲			▲/▲	
R/L105.0005.2.4	1,0	0,50	1,9	3,7	2,7	6,4	15	30	0,8	4		▲/▲				▲/▲
R105.0025.3.5	0,5	0,25	2,3	4,7	3,9	7,0	20	35	0,6	5	Δ	Δ	Δ			
R/L105.0005.3.5	1,0	0,50	2,3	4,7	3,5	7,0	20	35	1,0	5		▲/▲		x/x		▲/▲
R/L105.0007.1.5	1,5	0,75	2,3	4,7	3,5	7,0	10	25	1,0	5		Δ/Δ			▲/Δ	
R/L105.0007.3.5	1,5	0,75	2,3	4,7	3,5	7,0	20	35	1,0	5		▲/Δ				▲/▲
R/L105.0010.1.5	2,0	1,00	2,3	4,7	3,5	7,0	10	25	1,0	5		▲/Δ			▲/Δ	
R/L105.0010.3.5	2,0	1,00	2,3	4,7	3,5	7,0	20	35	1,0	5		▲/Δ				▲/▲

▲ ab Lager / on stock Δ 4 Wochen / 4 weeks x auf Anfrage / upon request

● empfohlen / recommended

o bedingt einsetzbar / alternative recommendation

- nicht geeignet / not suitable

unbeschichtete HM-Sorten / uncoated grades

beschichtete HM-Sorten / coated grades

bestückt/Cermet / brazed/Cermet

Abmessungen in mm

Dimensions in mm

Ausführung R oder L angeben

State R or L version

Weitere Abmessungen auf Anfrage

Further sizes upon request

	P	M	K	N	S	H
AN25	●	o	-	-	-	-
EG35	●	o	o	-	-	-
ES15	●	o	●	-	-	-
TF45	●	●	●	●	●	●
TH35	●	●	●	●	●	●
TN35	●	●	●	●	●	●

HM-Sorten
Carbide grades

Einstecken (innen)

Grooving (internal)



A

Schneidplatte

Insert

105

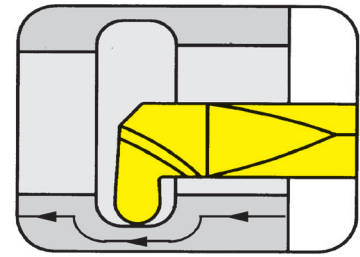

Bohrungs-Ø ab
Vollradius

Bore Ø from
Full radius

6 mm
0,5-1 mm

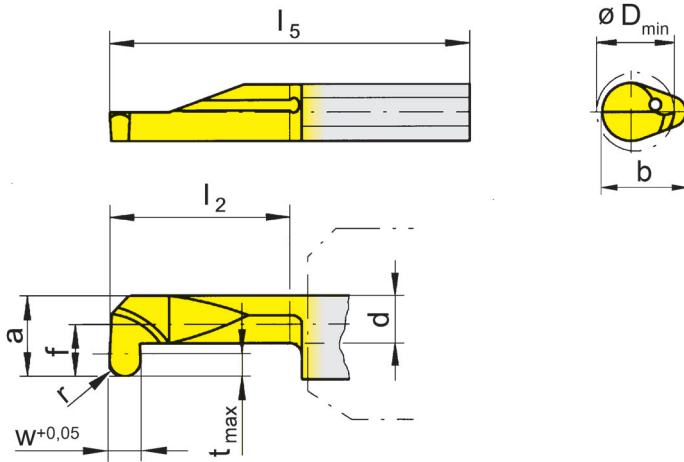

für Klemmhalter
for Toolholder

Typ H105
Type HC105
B105/BU105
BKT
IR105
962
AIH
963
N

Vollradius
Full radius

R = rechts wie gezeichnet
R = right hand version shown

L = links spiegelbildlich
L = left hand version

Bestellnummer Part number	w	r	f	a	d	b	l_2	l_5	t_{max}	D_{min}	EG35	TH35	TN35
R/L105.0005.2.6	1,0	0,50	3,3	5,7	3,7	7	15	30	1,8	6	▲/▲	▲/▲	
R/L105.0005.4.6	1,0	0,50	3,3	5,7	3,7	7	25	40	1,8	6	▲/▲		▲/▲
R/L105.0007.2.6	1,5	0,75	3,3	5,7	3,7	7	15	30	1,8	6	▲/▲	▲/▲	
R/L105.0007.4.6	1,5	0,75	3,3	5,7	3,7	7	25	40	1,8	6	▲/▲		▲/▲
R/L105.0010.2.6	2,0	1,00	3,3	5,7	3,7	7	15	30	1,8	6	▲/▲	▲/▲	
R/L105.0010.4.6	2,0	1,00	3,3	5,7	3,7	7	25	40	1,8	6	▲/▲		▲/▲

▲ ab Lager / on stock Δ 4 Wochen / 4 weeks x auf Anfrage / upon request

● empfohlen / recommended

o bedingt einsetzbar / alternative recommendation

- nicht geeignet / not suitable

■ unbeschichtete HM-Sorten / uncoated grades

■ beschichtete HM-Sorten / coated grades

■ bestückt/Cermet / brazed/Cermet

Abmessungen in mm

Dimensions in mm

Ausführung R oder L angeben

State R or L version

Weitere Abmessungen auf Anfrage

Further sizes upon request

P	●	●	●
M	●	●	●
K	○	●	●
N	-	●	●
S	-	●	●
H	-	-	-

HM-Sorten
Carbide grades

Einstecken (innen)

Grooving (internal)

Schneidplatte

Insert

105

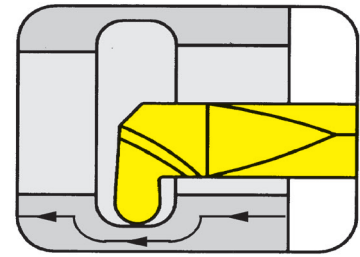

Bohrungs-Ø ab
Vollradius

Bore Ø from
Full radius

6,8 mm
0,5-1 mm

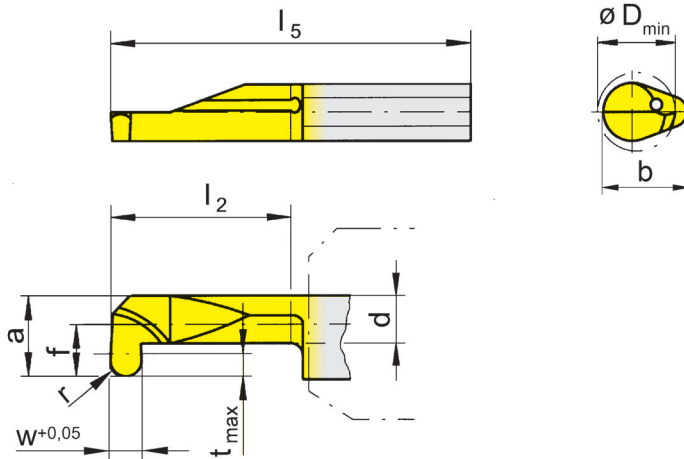

für Klemmhalter
for Toolholder

Typ H105
Type HC105
B105/BU105
BKT
IR105
962
AIH
963
N

Vollradius
Full radius

R = rechts wie gezeichnet
R = right hand version shown

L = links spiegelbildlich
L = left hand version

Bestellnummer Part number	w	r	f	a	d	b	l ₂	l ₅	t _{max}	D _{min}	EG35	TH35	TN35
R/L105.0005.3.7	1,0	0,50	4	6,4	3,7	7	20	35	2,5	6,8	▲/▲	▲/▲	
R/L105.0005.5.7	1,0	0,50	4	6,4	3,7	7	30	45	2,5	6,8	▲/▲		▲/▲
R/L105.0007.3.7	1,5	0,75	4	6,4	3,7	7	20	35	2,5	6,8	▲/▲	▲/▲	
R/L105.0007.5.7	1,5	0,75	4	6,4	3,7	7	30	45	2,5	6,8	▲/▲		▲/▲
R/L105.0010.3.7	2,0	1,00	4	6,4	3,7	7	20	35	2,5	6,8	▲/▲	▲/▲	
R/L105.0010.5.7	2,0	1,00	4	6,4	3,7	7	30	45	2,5	6,8	▲/▲		▲/▲

▲ ab Lager / on stock Δ 4 Wochen / 4 weeks x auf Anfrage / upon request

● empfohlen / recommended

o bedingt einsetzbar / alternative recommendation

- nicht geeignet / not suitable

■ unbeschichtete HM-Sorten / uncoated grades

■ beschichtete HM-Sorten / coated grades

■ bestückt/Cermet / brazed/Cermet

Abmessungen in mm

Dimensions in mm

Ausführung R oder L angeben

State R or L version

Weitere Abmessungen auf Anfrage

Further sizes upon request

P	●	●	●
M	●	●	●
K	○	●	●
N	-	●	●
S	-	●	●
H	-	-	-

HM-Sorten
Carbide grades

Einstecken (innen)

Grooving (internal)



A

Schneidplatte

Insert

105

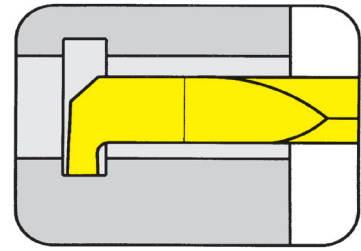

Bohrungs-Ø ab
Stechtiefe bis

Bore Ø from
Depth of groove up to

2 mm
0,4 mm

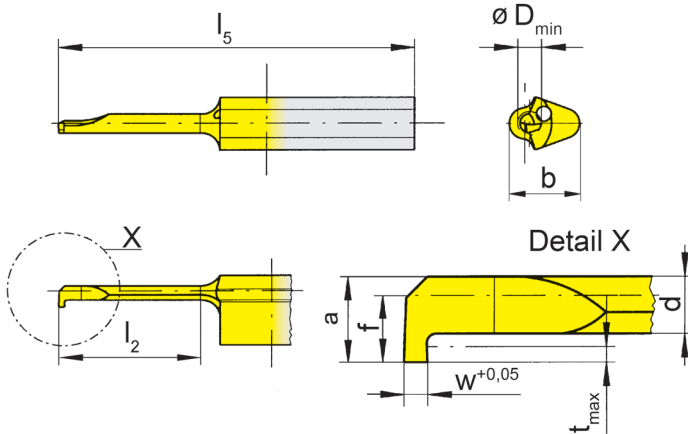

für Klemmhalter
for Toolholder

Typ H105
Type HC105
B105/BU105
BKT
IR105
962
AIH
963
N

R = rechts wie gezeichnet
R = right hand version shown

L = links spiegelbildlich
L = left hand version

Bestellnummer Part number	w	f	a	d	b	l ₂	l ₅	t _{max}	D _{min}	EG35	T125
R/L105.0050.0.2	0,5	1,4	1,8	1,2	5,9	6	25	0,4	2	▲/▲	▲/▲
R/L105.0050.1.2	0,5	1,4	1,8	1,2	5,9	9	25	0,4	2	▲/Δ	▲/▲
R/L105.0050.2.2	0,5	1,4	1,8	1,2	5,9	12	30	0,4	2	▲/Δ	▲/Δ

▲ ab Lager / on stock Δ 4 Wochen / 4 weeks x auf Anfrage / upon request

● empfohlen / recommended

o bedingt einsetzbar / alternative recommendation

- nicht geeignet / not suitable

■ unbeschichtete HM-Sorten / uncoated grades

■ beschichtete HM-Sorten / coated grades

■ bestückt/Cermet / brazed/Cermet

Abmessungen in mm

Dimensions in mm

Ausführung R oder L angeben

State R or L version

Weitere Abmessungen auf Anfrage

Further sizes upon request

P	•	•
M	•	•
K	o	•
N	-	•
S	-	•
H	-	-

HM-Sorten
Carbide grades

Einstecken (innen)

Grooving (internal)



Schneidplatte

105

Insert

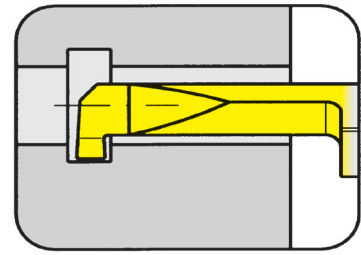

Bohrungs-Ø ab
Stechtiefe bis

Bore Ø from
Depth of groove up to

3 mm
0,6 mm

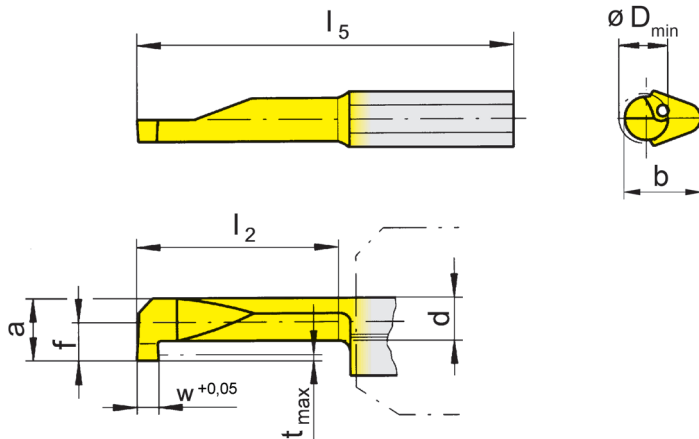

für Klemhalter
for Toolholder

Typ H105
Type HC105
B105/BU105
BKT
IR105
962
AIH
963
N

R = rechts wie gezeichnet
R = right hand version shown

L = links spiegelbildlich
L = left hand version

Bestellnummer Part number	w	f	a	d	b	l ₂	l ₅	t _{max}	D _{min}	HM-Sorten Carbide grades				
										MG12	AN25	EG35	ES15	TI25
R/L105.0070.1.3	0,7	1,4	2,7	1,9	5,9	8	25	0,6	3			▲/▲		▲/▲
R/L105.0070.2.3	0,7	1,4	2,7	1,9	5,9	12	30	0,6	3			▲/▲		▲/▲
R/L105.0070.3.3	0,7	1,4	2,7	1,9	5,9	16	35	0,6	3			▲/▲		▲/▲
R105.0050.1.3	0,5	1,4	2,7	2,0	5,9	8	25	0,5	3		Δ	Δ	Δ	
R105.0050.2.3	0,5	1,4	2,7	2,0	5,9	12	30	0,5	3	Δ	Δ	Δ	Δ	
R105.0050.3.3	0,5	1,4	2,7	2,0	5,9	16	35	0,5	3		Δ	Δ	Δ	

▲ ab Lager / on stock Δ 4 Wochen / 4 weeks x auf Anfrage / upon request

● empfohlen / recommended

o bedingt einsetzbar / alternative recommendation

- nicht geeignet / not suitable

■ unbeschichtete HM-Sorten / uncoated grades

■ beschichtete HM-Sorten / coated grades

■ bestückt/Cermet / brazed/Cermet

Abmessungen in mm

Dimensions in mm

Ausführung R oder L angeben

State R or L version

Weitere Abmessungen auf Anfrage

Further sizes upon request

P	o	●	●	●	●
M	-	o	●	o	●
K	-	-	o	●	●
N	-	-	-	-	●
S	-	-	-	-	●
H	-	-	-	-	-

HM-Sorten
Carbide grades

Einstecken (innen)

Grooving (internal)



A

Schneidplatte

Insert

105

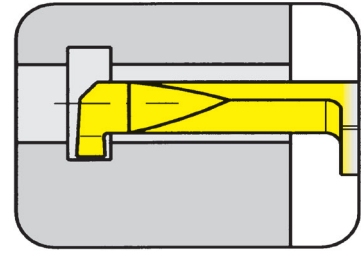

Bohrungs-Ø ab Stechtiefe bis	Bore Ø from Depth of groove up to	4 mm 0,8 mm
---------------------------------	--------------------------------------	----------------

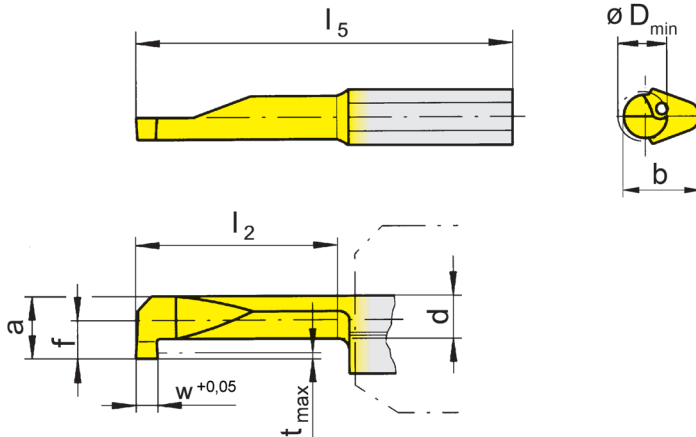

für Klemmhalter
for Toolholder

Typ H105
Type HC105
B105/BU105
BKT
IR105
962
AIH
963
N

R = rechts wie gezeichnet
R = right hand version shown

L = links spiegelbildlich
L = left hand version

Bestellnummer Part number	w	f	a	d	b	l ₂	l ₅	t _{max}	D _{min}	MG12	AN25	EG35	ES15	TN35
R105.0050.1.4	0,5	1,9	3,7	2,9	6,4	10	25	0,6	4		Δ	Δ	▲	
R105.0050.2.4	0,5	1,9	3,7	2,9	6,4	15	30	0,6	4		Δ	Δ	Δ	
R105.0050.3.4	0,5	1,9	3,7	2,9	6,4	20	35	0,6	4		Δ	Δ	Δ	
R/L105.0100.1.4	1,0	1,9	3,7	2,7	6,4	10	25	0,8	4	▲/▲		▲/Δ		▲/▲
R/L105.0100.2.4	1,0	1,9	3,7	2,7	6,4	15	30	0,8	4	▲/Δ		▲/Δ		▲/▲
R/L105.0100.3.4	1,0	1,9	3,7	2,7	6,4	20	35	0,8	4	▲/Δ		Δ/Δ		▲/▲

▲ ab Lager / on stock Δ 4 Wochen / 4 weeks x auf Anfrage / upon request

● empfohlen / recommended

o bedingt einsetzbar / alternative recommendation

- nicht geeignet / not suitable

unbeschichtete HM-Sorten / uncoated grades

beschichtete HM-Sorten / coated grades

bestückt/Cermet / brazed/Cermet

Abmessungen in mm

Dimensions in mm

Ausführung R oder L angeben

State R or L version

Weitere Abmessungen auf Anfrage

Further sizes upon request

P	o	●	●	●	●
M	-	o	●	o	●
K	-	-	o	●	●
N	-	-	-	-	●
S	-	-	-	-	●
H	-	-	-	-	-

HM-Sorten
Carbide grades

Einstecken (innen)

Grooving (internal)



Schneidplatte

Insert

105

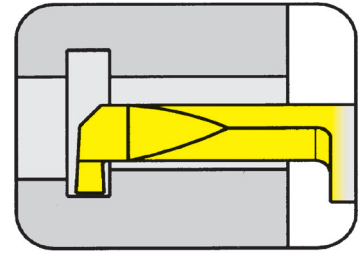

Bohrungs-Ø ab
Stechtiefe bis

Bore Ø from
Depth of groove up to

5 mm
1 mm

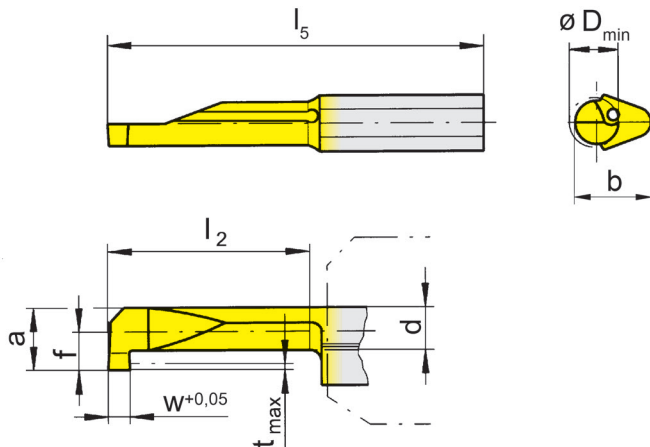

für Klemmhalter
for Toolholder

Typ H105
Type HC105
B105/BU105
BKT
IR105
962
AIH
963
N

R = rechts wie gezeichnet
R = right hand version shown

L = links spiegelbildlich
L = left hand version

Bestellnummer Part number	w	f	a	d	b	l ₂	l ₅	t _{max}	D _{min}	MG12	EG35	TH35	TN35
R/L105.0100.1.5	1,0	2,3	4,7	3,5	7	10	25	1	5	▲/▲	▲/▲	▲/▲	▲/▲
R/L105.0100.2.5	1,0	2,3	4,7	3,5	7	15	30	1	5	▲/▲	▲/▲	▲/▲	▲/▲
R/L105.0100.3.5	1,0	2,3	4,7	3,5	7	20	35	1	5	▲/▲	▲/▲	▲/▲	▲/▲
R/L105.0100.4.5	1,0	2,3	4,7	3,5	7	25	40	1	5		▲/▲	▲/▲	▲/▲
R/L105.0100.5.5	1,0	2,3	4,7	3,5	7	30	45	1	5		▲/▲	▲/▲	▲/▲
R/L105.0150.1.5	1,5	2,3	4,7	3,5	7	10	25	1	5	▲/▲	▲/▲	▲/▲	▲/▲
R/L105.0150.2.5	1,5	2,3	4,7	3,5	7	15	30	1	5	▲/▲	▲/▲	▲/▲	▲/▲
R/L105.0150.3.5	1,5	2,3	4,7	3,5	7	20	35	1	5	▲/▲	▲/▲	▲/▲	▲/▲
R/L105.0150.4.5	1,5	2,3	4,7	3,5	7	25	40	1	5		▲/▲	▲/▲	▲/▲
R/L105.0150.5.5	1,5	2,3	4,7	3,5	7	30	45	1	5		▲/▲	▲/▲	▲/▲
R/L105.0200.1.5	2,0	2,3	4,7	3,5	7	10	25	1	5	▲/▲	▲/▲	▲/▲	▲/▲
R/L105.0200.2.5	2,0	2,3	4,7	3,5	7	15	30	1	5	▲/▲	▲/▲	▲/▲	▲/▲
R/L105.0200.3.5	2,0	2,3	4,7	3,5	7	20	35	1	5	▲/x	▲/▲	▲/▲	▲/▲
R/L105.0200.4.5	2,0	2,3	4,7	3,5	7	25	40	1	5		▲/▲	▲/▲	▲/▲
R/L105.0200.5.5	2,0	2,3	4,7	3,5	7	30	45	1	5		▲/▲	▲/▲	▲/▲

▲ ab Lager / on stock Δ 4 Wochen / 4 weeks x auf Anfrage / upon request

● empfohlen / recommended

o bedingt einsetzbar / alternative recommendation

- nicht geeignet / not suitable

■ unbeschichtete HM-Sorten / uncoated grades

■ beschichtete HM-Sorten / coated grades

■ bestückt/Cermet / brazed/Cermet

Abmessungen in mm

Dimensions in mm

Ausführung R oder L angeben

State R or L version

Weitere Abmessungen auf Anfrage

Further sizes upon request

	P	M	K	N	S	H
o	●	●	●	●	●	●
-	-	●	●	●	●	●
-	-	o	●	●	●	●
-	-	-	●	●	●	●
-	-	-	●	●	●	●
-	-	-	-	-	-	-

HM-Sorten
Carbide grades

Einstechen (innen)

Grooving (internal)



A

Schneidplatte

Insert

105

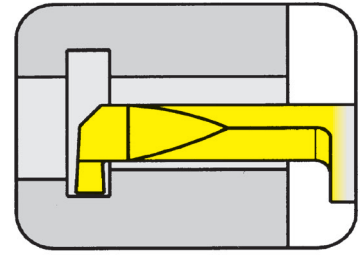

Bohrungs-Ø ab
Stechtiefe bis

Bore Ø from
Depth of groove up to

6 mm
1,8 mm

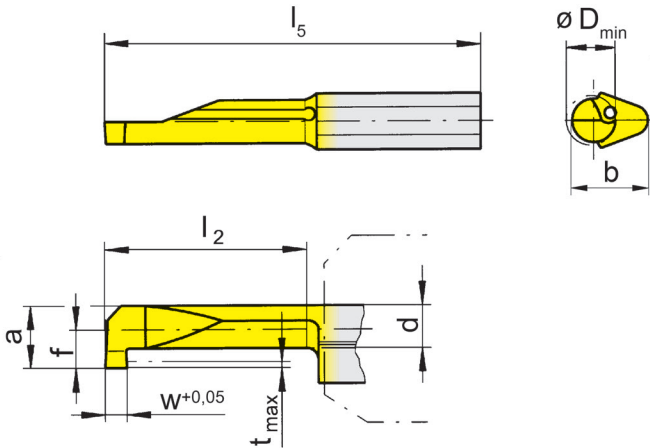

für Klemmhalter
for Toolholder

Typ H105
Type HC105
B105/BU105
BKT
IR105
962
AIH
963
N

R = rechts wie gezeichnet
R = right hand version shown

L = links spiegelbildlich
L = left hand version

Bestellnummer Part number	w	f	a	d	b	l ₂	l ₅	t _{max}	D _{min}	MG12	EG35	TH35	TN35
R/L105.0100.1.6	1,0	3,3	5,7	3,7	7	10	25	1,8	6	▲/▲	▲/▲	▲/▲	▲/▲
R/L105.0100.2.6	1,0	3,3	5,7	3,7	7	15	30	1,8	6	▲/▲	▲/▲	▲/▲	▲/▲
R/L105.0100.3.6	1,0	3,3	5,7	3,7	7	20	35	1,8	6	▲/▲	▲/▲	▲/▲	▲/▲
R/L105.0100.4.6	1,0	3,3	5,7	3,7	7	25	40	1,8	6		▲/▲	▲/▲	▲/▲
R/L105.0100.5.6	1,0	3,3	5,7	3,7	7	30	45	1,8	6		▲/▲	▲/▲	▲/▲
R/L105.0150.1.6	1,5	3,3	5,7	3,7	7	10	25	1,8	6	▲/▲	▲/▲	▲/▲	▲/▲
R/L105.0150.2.6	1,5	3,3	5,7	3,7	7	15	30	1,8	6	▲/▲	▲/▲	▲/▲	▲/▲
R/L105.0150.3.6	1,5	3,3	5,7	3,7	7	20	35	1,8	6	▲/▲	▲/▲	▲/▲	▲/▲
R/L105.0150.4.6	1,5	3,3	5,7	3,7	7	25	40	1,8	6		▲/▲	▲/▲	▲/▲
R/L105.0150.5.6	1,5	3,3	5,7	3,7	7	30	45	1,8	6		▲/▲	▲/▲	▲/▲
R/L105.0200.1.6	2,0	3,3	5,7	3,7	7	10	25	1,8	6	▲/▲	▲/▲	▲/▲	▲/▲
R/L105.0200.2.6	2,0	3,3	5,7	3,7	7	15	30	1,8	6	▲/▲	▲/▲	▲/▲	▲/▲
R/L105.0200.3.6	2,0	3,3	5,7	3,7	7	20	35	1,8	6	▲/▲	▲/▲	▲/▲	▲/▲
R/L105.0200.4.6	2,0	3,3	5,7	3,7	7	25	40	1,8	6		▲/▲	▲/▲	▲/▲
R/L105.0200.5.6	2,0	3,3	5,7	3,7	7	30	45	1,8	6		▲/▲	▲/▲	▲/▲

- ▲ ab Lager / on stock Δ 4 Wochen / 4 weeks x auf Anfrage / upon request
- empfohlen / recommended
- o bedingt einsetzbar / alternative recommendation
- nicht geeignet / not suitable
- unbeschichtete HM-Sorten / uncoated grades
- beschichtete HM-Sorten / coated grades
- bestückt/Cermet / brazed/Cermet

P	o	●	●	●
M	-	●	●	●
K	-	o	●	●
N	-	-	●	●
S	-	-	●	●
H	-	-	-	-

Abmessungen in mm
Dimensions in mm

Ausführung R oder L angeben
State R or L version

Weitere Abmessungen auf Anfrage
Further sizes upon request

HM-Sorten
Carbide grades

Einstecken (innen)

Grooving (internal)



Schneidplatte

Insert

105

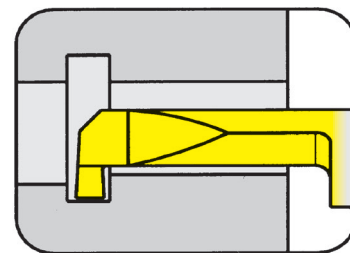

Bohrungs-Ø ab
Stechtiefe bis

Bore Ø from
Depth of groove up to

6,8 mm
2,5 mm

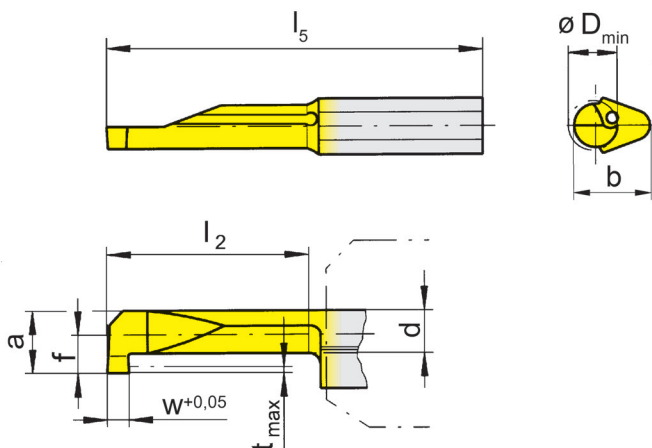

für Klemmhalter
for Toolholder

Typ H105
Type HC105
B105/BU105
BKT
IR105
962
AIH
963
N

R = rechts wie gezeichnet
R = right hand version shown

L = links spiegelbildlich
L = left hand version

Bestellnummer Part number	w	f	a	d	b	l_2	l_5	t_{max}	D_{min}	MG12	EG35	TH35	TN35
R/L105.0100.1.7	1,0	4	6,4	3,7	7	10	25	2,5	6,8	▲/▲	▲/▲	▲/▲	▲/▲
R/L105.0100.2.7	1,0	4	6,4	3,7	7	15	30	2,5	6,8	▲/Δ	▲/▲	▲/▲	▲/▲
R/L105.0100.3.7	1,0	4	6,4	3,7	7	20	35	2,5	6,8	▲/▲	Δ/▲	▲/▲	▲/▲
R/L105.0100.4.7	1,0	4	6,4	3,7	7	25	40	2,5	6,8		▲/Δ	▲/Δ	▲/▲
R/L105.0100.5.7	1,0	4	6,4	3,7	7	30	45	2,5	6,8		Δ/Δ	▲/▲	▲/▲
R/L105.0150.1.7	1,5	4	6,4	3,7	7	10	25	2,5	6,8	▲/▲	▲/▲	▲/▲	▲/▲
R/L105.0150.2.7	1,5	4	6,4	3,7	7	15	30	2,5	6,8	▲/▲	▲/▲	▲/▲	▲/▲
R/L105.0150.3.7	1,5	4	6,4	3,7	7	20	35	2,5	6,8	▲/Δ	▲/▲	▲/▲	▲/▲
R/L105.0150.4.7	1,5	4	6,4	3,7	7	25	40	2,5	6,8		▲/Δ	▲/▲	▲/▲
R/L105.0150.5.7	1,5	4	6,4	3,7	7	30	45	2,5	6,8		▲/Δ	▲/▲	▲/▲
R/L105.0200.1.7	2,0	4	6,4	3,7	7	10	25	2,5	6,8	▲/▲	▲/▲	▲/▲	▲/▲
R/L105.0200.2.7	2,0	4	6,4	3,7	7	15	30	2,5	6,8	▲/▲	▲/Δ	▲/▲	▲/▲
R/L105.0200.3.7	2,0	4	6,4	3,7	7	20	35	2,5	6,8	▲/Δ	▲/Δ	▲/▲	▲/▲
R/L105.0200.4.7	2,0	4	6,4	3,7	7	25	40	2,5	6,8		▲/Δ	▲/▲	▲/▲
R/L105.0200.5.7	2,0	4	6,4	3,7	7	30	45	2,5	6,8		Δ/Δ	▲/▲	▲/▲

▲ ab Lager / on stock Δ 4 Wochen / 4 weeks x auf Anfrage / upon request

● empfohlen / recommended

o bedingt einsetzbar / alternative recommendation

- nicht geeignet / not suitable

■ unbeschichtete HM-Sorten / uncoated grades

■ beschichtete HM-Sorten / coated grades

■ bestückt/Cermet / brazed/Cermet

Abmessungen in mm

Dimensions in mm

Ausführung R oder L angeben

State R or L version

Weitere Abmessungen auf Anfrage

Further sizes upon request

P	o	●	●	●
M	-	●	●	●
K	-	o	●	●
N	-	-	●	●
S	-	-	●	●
H	-	-	-	-

HM-Sorten
Carbide grades

Gewindedrehen (innen) Teilprofil

Threading (internal) Partial profile



A

Schneidplatte

105

Insert

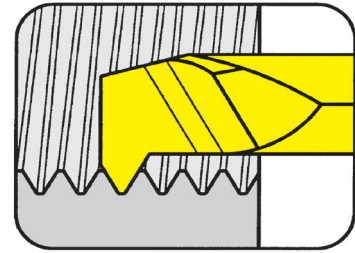

Bohrungs-Ø ab
Steigung

Bore Ø from
Pitch

3 mm
P 0,25 mm

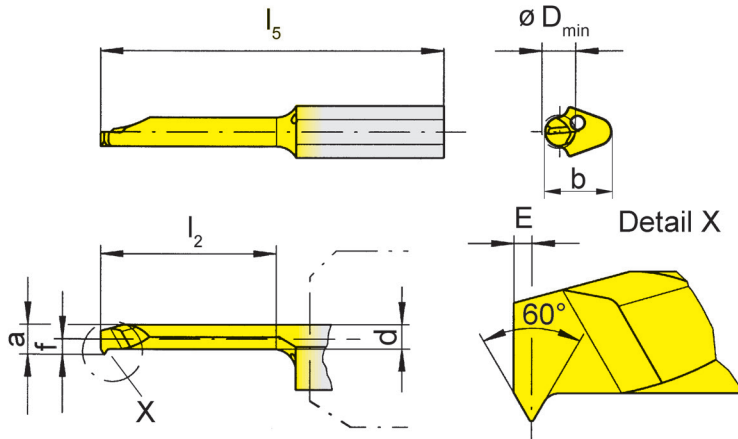

für Klemmhalter
for Toolholder

Typ H105
Type HC105
B105/BU105
BKT
IR105
962
AIH
963
N

Metrisches ISO-Gewinde
Metric ISO thread

R = rechts wie gezeichnet
R = right hand version shown

L = links spiegelbildlich
L = left hand version

Bestellnummer Part number	P	E	f	a	d	b	l ₂	l ₅	D _{min}	EG35 Δ/Δ	TN35 ▲/▲
R/L105.0102.2.3	0,25	0,3	1,4	2,7	2,2	5,9	15	30	3		

▲ ab Lager / on stock Δ 4 Wochen / 4 weeks x auf Anfrage / upon request

● empfohlen / recommended

o bedingt einsetzbar / alternative recommendation

- nicht geeignet / not suitable

■ unbeschichtete HM-Sorten / uncoated grades

■ beschichtete HM-Sorten / coated grades

■ bestückt/Cermet / brazed/Cermet

Abmessungen in mm

Dimensions in mm

Ausführung R oder L angeben

State R or L version

Weitere Abmessungen auf Anfrage

Further sizes upon request

P	•	•
M	•	•
K	o	•
N	-	•
S	-	•
H	-	-

HM-Sorten
Carbide grades

Gewindedrehen (innen) Teilprofil

Threading (internal) Partial profile



Schneidplatte

Insert

105

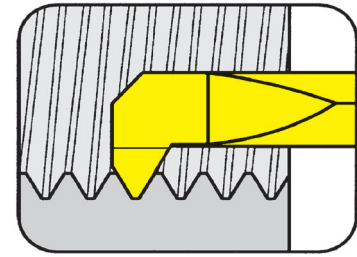

Bohrungs-Ø ab
Steigung

Bore Ø from
Pitch

3 mm
P 0,35 mm

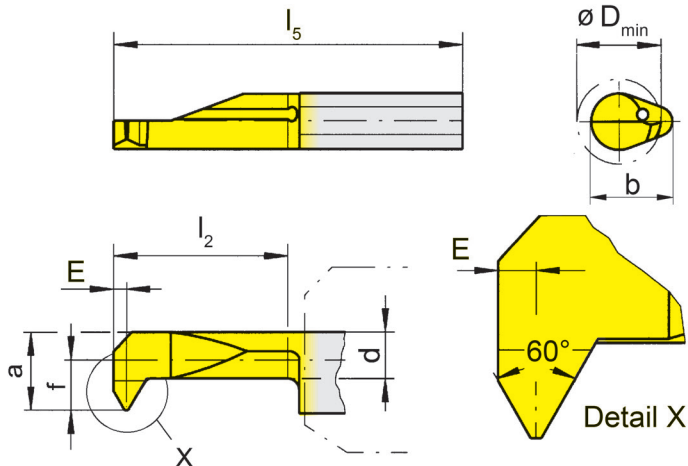

R = rechts wie gezeichnet
R = right hand version shown

L = links spiegelbildlich
L = left hand version

für Klemhalter
for Toolholder

Typ H105
Type HC105
B105/BU105
BKT
IR105
962
AIH
963
N

Metrisches ISO-Gewinde
Metric ISO thread

Bestellnummer Part number	P	E	f	a	d	b	l_2	l_5	D_{min}	EG35	TN35
R/L105.0203.1.3	0,35	0,3	1,4	2,7	2,1	5,9	10	25	3	▲/Δ	▲/Δ
R/L105.0203.2.5	0,35	0,3	2,3	4,7	3,5	7,0	15	30	5	▲/Δ	▲/▲

▲ ab Lager / on stock Δ 4 Wochen / 4 weeks x auf Anfrage / upon request

● empfohlen / recommended

o bedingt einsetzbar / alternative recommendation

- nicht geeignet / not suitable

■ unbeschichtete HM-Sorten / uncoated grades

■ beschichtete HM-Sorten / coated grades

■ bestückt/Cermet / brazed/Cermet

Abmessungen in mm

Dimensions in mm

Ausführung R oder L angeben

State R or L version

Weitere Abmessungen auf Anfrage

Further sizes upon request

P	•	•
M	•	•
K	o	•
N	-	•
S	-	•
H	-	-

HM-Sorten
Carbide grades

Gewindedrehen (innen) Teilprofil

Threading (internal) Partial profile



A

Schneidplatte

Insert

105

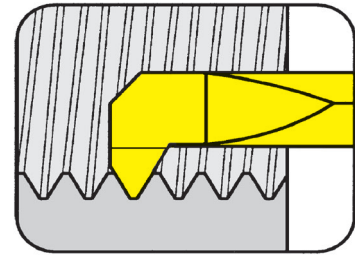

Bohrungs-Ø ab Steigung	Bore Ø from Pitch	3 mm P 0,5 mm
------------------------	-------------------	------------------

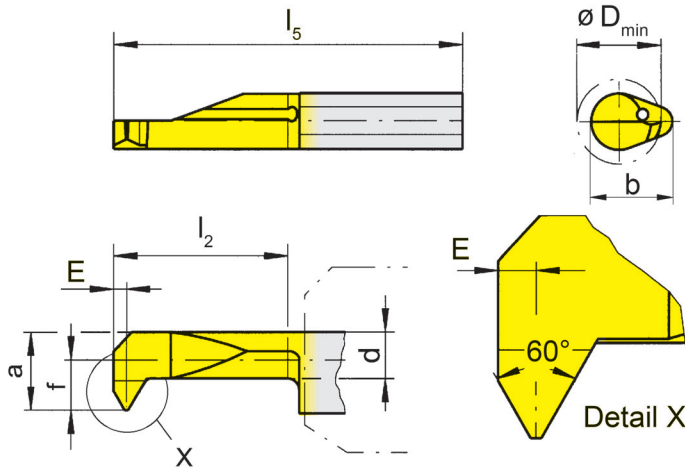

für Klemhalter
for Toolholder

Typ H105
Type HC105
B105/BU105
BKT
IR105
962
AIH
963
N

Metrisches ISO-Gewinde
Metric ISO thread

R = rechts wie gezeichnet
R = right hand version shown

L = links spiegelbildlich
L = left hand version

Bestellnummer Part number	P	E	f	a	d	b	l ₂	l ₅	D _{min}	MG12	EG35	TH35	TN35
R/L105.0205.2.3	0,5	0,35	1,4	2,7	2,1	5,9	15	30	3		▲/Δ		▲/▲
R/L105.0205.2.4	0,5	0,35	1,9	3,7	2,7	6,4	15	30	4		▲/Δ	▲/Δ	▲/▲
R/L105.0205.3.4	0,5	0,35	1,9	3,7	2,7	6,4	20	35	4		▲/Δ		▲/Δ
R/L105.0205.2.5	0,5	0,35	2,3	4,7	3,5	7,0	15	30	5	▲/Δ	▲/Δ	▲/Δ	▲/▲
R/L105.0205.3.5	0,5	0,35	2,3	4,7	3,5	7,0	20	35	5		Δ/Δ		▲/Δ
R/L105.0205.4.5	0,5	0,35	2,3	4,7	3,5	7,0	25	40	5		Δ/Δ		▲/Δ
R/L105.0205.3.6	0,5	0,35	3,3	5,7	4,8	7,0	20	35	6		▲/Δ		▲/Δ

▲ ab Lager / on stock Δ 4 Wochen / 4 weeks x auf Anfrage / upon request

● empfohlen / recommended

o bedingt einsetzbar / alternative recommendation

- nicht geeignet / not suitable

■ unbeschichtete HM-Sorten / uncoated grades

■ beschichtete HM-Sorten / coated grades

■ bestückt/Cermet / brazed/Cermet

Abmessungen in mm

Dimensions in mm

Ausführung R oder L angeben

State R or L version

Weitere Abmessungen auf Anfrage

Further sizes upon request

P	○	●	●	●
M	-	●	●	●
K	-	○	●	●
N	-	-	●	●
S	-	-	●	●
H	-	-	-	-

HM-Sorten
Carbide grades

Gewindedrehen (innen) Teilprofil

Threading (internal) Partial profile



Schneidplatte

105

Insert

Bohrungs-Ø ab
Steigung

Bore Ø from
Pitch

3 mm
P 0,5-0,75 mm

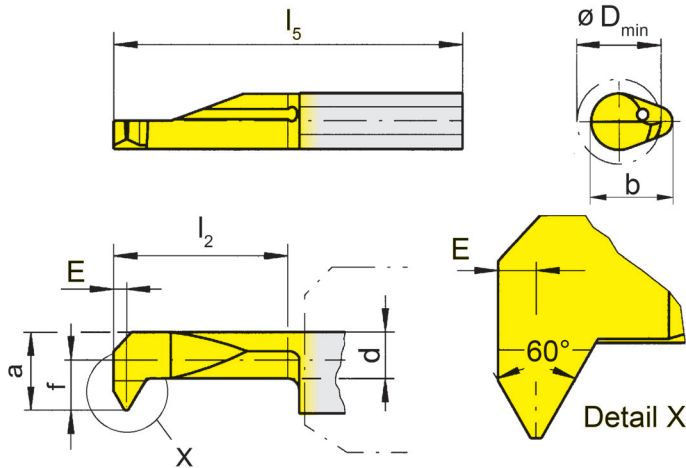
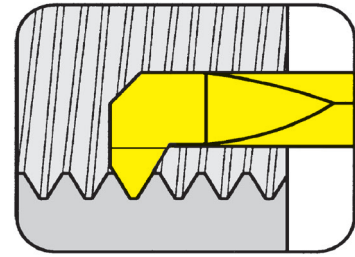

für Klemhalter
for Toolholder

Typ H105
Type HC105
B105/BU105
BKT
IR105
962
AIH
963
N

Metrisches ISO-Gewinde
Metric ISO thread

R = rechts wie gezeichnet
R = right hand version shown

L = links spiegelbildlich
L = left hand version

Bestellnummer Part number	P	P _{max}	E	f	a	d	b	l ₂	l ₅	D _{min}	EG35	TH35	TN35
R/L105.0407.2.3	0,5	0,75	0,45	1,4	2,7	2,0	5,9	15	30	3	▲/Δ		▲/Δ
R/L105.0407.1.4	0,5	0,75	0,45	1,9	3,7	2,7	6,4	10	25	4	▲/Δ		▲/▲
R/L105.0407.3.4	0,5	0,75	0,45	1,9	3,7	2,7	6,4	20	35	4	▲/Δ		▲/Δ
R/L105.0407.2.4	0,5	0,75	0,45	1,9	3,7	2,7	6,4	15	30	4	▲/Δ		▲/▲
R/L105.0407.2.5	0,5	0,75	0,45	2,3	4,7	3,5	7,0	15	30	5	▲/▲	▲/▲	▲/▲
R/L105.0407.3.5	0,5	0,75	0,45	2,3	4,7	3,5	7,0	20	35	5	Δ/Δ		▲/Δ
R/L105.0407.4.5	0,5	0,75	0,45	2,3	4,7	3,5	7,0	25	40	5	▲/Δ		▲/Δ
R/L105.0407.3.6	0,5	0,75	0,45	3,3	5,7	4,7	7,0	20	35	6	▲/Δ		▲/Δ

▲ ab Lager / on stock Δ 4 Wochen / 4 weeks x auf Anfrage / upon request

● empfohlen / recommended

o bedingt einsetzbar / alternative recommendation

- nicht geeignet / not suitable

■ unbeschichtete HM-Sorten / uncoated grades

■ beschichtete HM-Sorten / coated grades

■ bestückt/Cermet / brazed/Cermet

Abmessungen in mm

Dimensions in mm

Ausführung R oder L angeben

State R or L version

Weitere Abmessungen auf Anfrage

Further sizes upon request

	P	M	K	N	S	H
EG35	●	●	●	-	-	-
TH35	●	●	●	-	-	-
TN35	●	●	●	●	●	-

HM-Sorten
Carbide grades

Gewindedrehen (innen) Teilprofil

Threading (internal) Partial profile



A

Schneidplatte

Insert

105

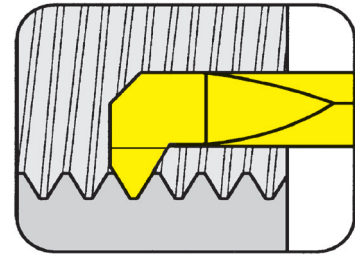

Bohrungs-Ø ab Steigung

Bore Ø from Pitch

4,8 mm
P 1-1,5 mm

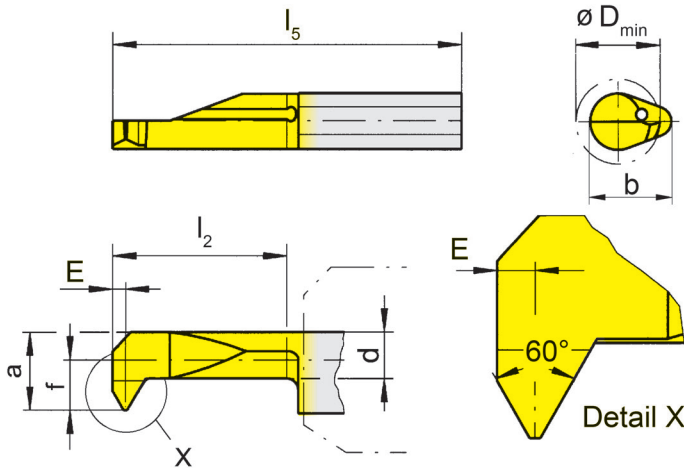

für Klemmhalter
for Toolholder

Typ H105
Type HC105
B105/BU105
BKT
IR105
962
AIH
963
N

Metrisches ISO-Gewinde
Metric ISO thread

R = rechts wie gezeichnet
R = right hand version shown

L = links spiegelbildlich
L = left hand version

Bestellnummer Part number	P	P _{max}	E	f	a	d	b	l ₂	l ₅	D _{min}	MG12	EG35	TF45	TH35	TI25	TN35
R/L105.0510.2.5	1,00	1,00	0,55	2,1	4,5	3,5	7	15	30	4,8	▲/Δ	▲/▲		▲/▲	Δ/x	▲/▲
R/L105.0510.3.5	1,00	1,00	0,55	2,1	4,5	3,5	7	20	35	4,8		▲/Δ				▲/▲
R/L105.0510.4.5	1,00	1,00	0,55	2,1	4,5	3,5	7	25	40	4,8		▲/Δ				▲/▲
R/L105.0510.2.6	1,00	1,00	0,55	3,3	5,7	3,7	7	15	30	6,0		▲/▲		▲/▲		▲/▲
R/L105.0612.2.6	1,25	1,25	0,65	3,3	5,7	3,7	7	15	30	6,0	Δ/Δ	▲/▲		▲/▲		▲/▲
R/L105.0612.3.6	1,25	1,25	0,65	3,3	5,7	3,7	7	20	35	6,0		▲/Δ				▲/▲
R/L105.0612.4.6	1,25	1,25	0,65	3,3	5,7	3,7	7	25	40	6,0		▲/Δ				▲/▲
R/L105.0815.2.7	1,50	1,50	0,75	4,0	6,4	3,7	7	15	30	7,0		▲/Δ	Δ/x	▲/▲		▲/▲
R/L105.0815.3.7	1,50	1,50	0,75	4,0	6,4	3,7	7	20	35	7,0		▲/Δ				▲/▲
R/L105.0815.4.7	1,50	1,50	0,75	4,0	6,4	3,7	7	25	40	7,0		▲/Δ				▲/▲

▲ ab Lager / on stock Δ 4 Wochen / 4 weeks x auf Anfrage / upon request

● empfohlen / recommended

o bedingt einsetzbar / alternative recommendation

- nicht geeignet / not suitable

unbeschichtete HM-Sorten / uncoated grades

beschichtete HM-Sorten / coated grades

bestückt/Cermet / brazed/Cermet

Abmessungen in mm

Dimensions in mm

Ausführung R oder L angeben

State R or L version

Weitere Abmessungen auf Anfrage

Further sizes upon request

	P	M	K	N	S	H
MG12	○	●	●	●	●	●
EG35	-	●	●	●	●	●
TF45	-	○	●	●	●	●
TH35	-	-	●	●	●	●
TI25	-	-	●	●	●	●
TN35	-	-	-	-	-	-

HM-Sorten
Carbide grades

Gewindedrehen (innen) Vollprofil

Threading (internal) Full profile



Schneidplatte

105

Insert

Bohrungs-Ø ab
Steigung

Bore Ø from
Pitch

2,4 mm
P 0,5-1,25 mm

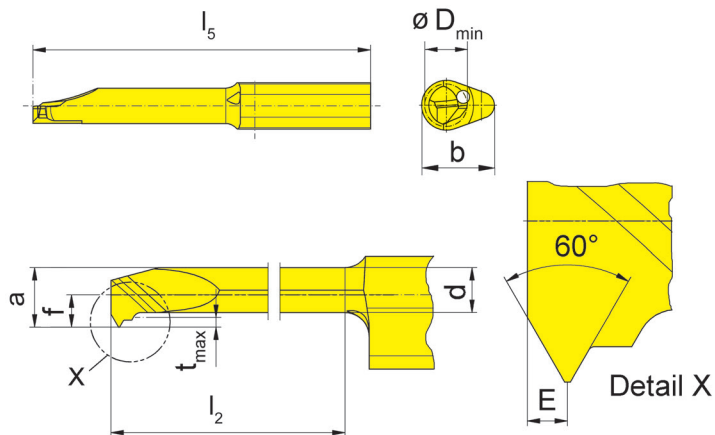
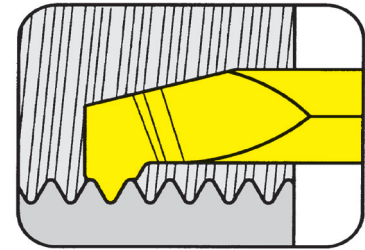

für Klemmhalter
for Toolholder

Typ H105
Type HC105
B105/BU105
BKT
IR105
962
AIH
963
N

Metrisches ISO-Gewinde
Metric ISO thread

R = rechts wie gezeichnet
R = right hand version shown

L = links spiegelbildlich
L = left hand version

Bestellnummer Part number	P	E	f	a	d	b	l ₂	l ₅	D _{min}	EG35	TH35
R/L105.VPM3.2.3	0,50	0,3	1,4	2,2	1,65	5,9	9	25	2,4	▲/▲	▲/▲
R/L105.VPM3.4.3	0,50	0,3	1,4	2,2	1,65	5,9	16	35	2,4	▲/▲	▲/▲
R/L105.VPM4.2.4	0,70	0,4	1,5	2,9	2,10	6,4	15	30	3,2	▲/▲	▲/▲
R/L105.VPM4.3.4	0,70	0,4	1,5	2,9	2,10	6,4	20	35	3,2	▲/▲	▲/▲
R/L105.VPM5.2.5	0,80	0,5	2,0	3,7	2,80	7,0	15	30	4,1	▲/▲	▲/▲
R/L105.VPM5.4.5	0,80	0,5	2,0	3,7	2,80	7,0	25	40	4,1	▲/▲	▲/▲
R/L105.VPM6.3.6	1,00	0,5	2,4	4,5	3,40	7,0	20	35	4,9	▲/▲	▲/▲
R/L105.VPM6.4.6	1,00	0,5	2,4	4,5	3,40	7,0	25	40	4,9	▲/▲	▲/▲
R/L105.VPM6.5.6	1,00	0,5	2,4	4,5	3,40	7,0	30	45	4,9	▲/▲	▲/▲
R/L105.VPM8.3.8	1,25	0,7	3,8	6,2	4,70	7,0	20	35	6,6	▲/▲	▲/▲
R/L105.VPM8.5.8	1,25	0,7	3,8	6,2	4,70	7,0	30	45	6,6	▲/▲	▲/▲

▲ ab Lager / on stock Δ 4 Wochen / 4 weeks x auf Anfrage / upon request

● empfohlen / recommended

o bedingt einsetzbar / alternative recommendation

- nicht geeignet / not suitable

■ unbeschichtete HM-Sorten / uncoated grades

■ beschichtete HM-Sorten / coated grades

■ bestückt/Cermet / brazed/Cermet

Abmessungen in mm

Dimensions in mm

Ausführung R oder L angeben

State R or L version

Weitere Abmessungen auf Anfrage

Further sizes upon request

	P	M	K	N	S	H
EG35	•	•	•	-	-	-
TH35	•	•	•	•	•	-

HM-Sorten
Carbide grades

Gewindedrehen (innen) Teilprofil

Threading (internal) Partial profile



A

Schneidplatte

Insert

105

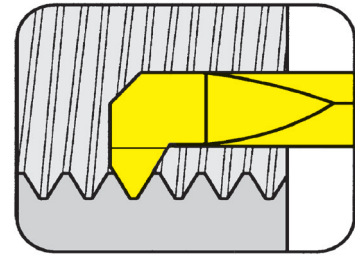

Bohrungs-Ø ab Gang pro Zoll	Bore Ø from Threads per inch	4 mm 16-40
--------------------------------	---------------------------------	---------------

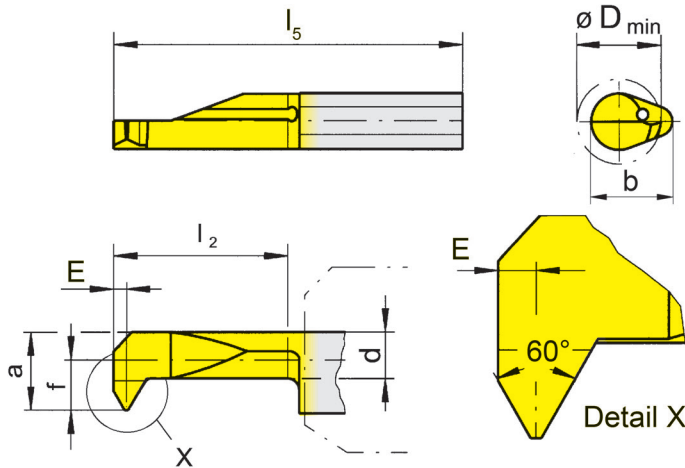

für Klemhalter
for Toolholder

Typ H105
Type HC105
B105/BU105
BKT
IR105
962
AIH
963
N

Gewinde UN
Thread UN

R = rechts wie gezeichnet
R = right hand version shown

L = links spiegelbildlich
L = left hand version

Bestellnummer Part number	TPI _{min}	TPI _{max}	E	f	a	d	b	l ₂	l ₅	D _{min}	MG12	EG35	TF45	TH35	TI25	TN35
R/L105.3240.2.4	32	40	0,45	1,9	3,7	2,7	6,4	15	30	4		▲/Δ	x/x		Δ/x	▲/▲
R/L105.1620.2.5	16	20	0,70	2,3	4,7	3,3	7,0	15	30	5		▲/Δ		▲/▲		
R/L105.1620.3.5	16	20	0,70	2,3	4,7	3,3	7,0	20	35	5		Δ/Δ		▲/Δ		
R/L105.2428.2.5	24	28	0,55	2,3	4,7	3,5	7,0	15	30	5		▲/Δ		x/x	Δ/x	▲/▲
R/L105.3240.2.5	32	40	0,45	2,3	4,7	3,5	7,0	15	30	5		▲/Δ	Δ/x		Δ/x	▲/▲
R/L105.1620.2.6	16	20	0,70	3,3	5,7	3,7	7,0	15	30	6		▲/▲	Δ/x	Δ/x	Δ/x	▲/▲
R/L105.1620.3.6	16	20	0,70	3,3	5,7	3,7	7,0	20	35	6		▲/Δ				▲/Δ
R/L105.1620.4.6	16	20	0,70	3,3	5,7	3,7	7,0	25	40	6		▲/Δ				▲/Δ
R/L105.2428.2.6	24	28	0,55	3,3	5,7	3,7	7,0	15	30	6	Δ/x	▲/▲			Δ/x	▲/▲
R/L105.2428.3.6	24	28	0,55	3,3	5,7	3,7	7,0	20	35	6		▲/Δ				▲/Δ
R/L105.2428.4.6	24	28	0,55	3,3	5,7	3,7	7,0	25	40	6		▲/Δ				▲/▲

▲ ab Lager / on stock Δ 4 Wochen / 4 weeks x auf Anfrage / upon request

● empfohlen / recommended

o bedingt einsetzbar / alternative recommendation

- nicht geeignet / not suitable

■ unbeschichtete HM-Sorten / uncoated grades

■ beschichtete HM-Sorten / coated grades

■ bestückt/Cermet / brazed/Cermet

Abmessungen in mm

Dimensions in mm

Ausführung R oder L angeben

State R or L version

Weitere Abmessungen auf Anfrage

Further sizes upon request

P	o	●	●	●	●	●
M	-	●	●	●	●	●
K	-	o	●	●	●	●
N	-	-	●	●	●	●
S	-	-	●	●	●	●
H	-	-	-	-	-	-

HM-Sorten
Carbide grades

Gewindedrehen (innen) Vollprofil

Threading (internal) Full profile



Schneidplatte

Insert

105

Whitworth-Gewinde
Whitworth thread

Bohrungs-Ø ab
Gang pro Zoll

Bore Ø from
Threads per inch

4 mm
20-28

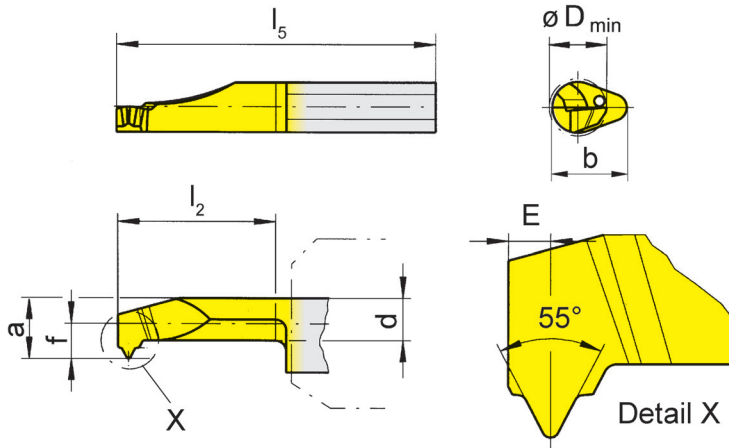
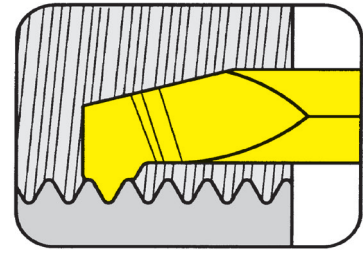

für Klemmhalter
for Toolholder

Typ H105
Type HC105
B105/BU105
BKT
IR105
962
AIH
963
N

Gewinde BSW/BSF
Thread BSW/BSF

R = rechts wie gezeichnet
R = right hand version shown

L = links spiegelbildlich
L = left hand version

Bestellnummer Part number	TPI	E	f	a	d	b	l_2	l_5	D_{min}	EG35	TN35
R105.5520.2.4	20	1,0	1,9	3,7	2,5	6,4	15	30	4	▲	▲
R/L105.5524.2.5	24	0,8	2,3	4,7	3,5	7,0	15	30	5	△/△	△/△
R/L105.5526.2.5	26	0,8	2,3	4,7	3,5	7,0	15	30	5	△/△	▲/△
R/L105.5528.2.5	28	0,8	2,3	4,7	3,5	7,0	15	30	5	▲/△	▲/△

▲ ab Lager / on stock △ 4 Wochen / 4 weeks x auf Anfrage / upon request

● empfohlen / recommended

o bedingt einsetzbar / alternative recommendation

- nicht geeignet / not suitable

■ unbeschichtete HM-Sorten / uncoated grades

■ beschichtete HM-Sorten / coated grades

■ bestückt/Cermet / brazed/Cermet

Abmessungen in mm

Dimensions in mm

Weitere Abmessungen auf Anfrage

Further sizes upon request

	EG35	TN35
P	•	•
M	•	•
K	o	•
N	-	•
S	-	•
H	-	-

HM-Sorten
Carbide grades

Gewindedrehen (innen) Vollprofil

Threading (internal) Full profile



A

Schneidplatte

Insert

105

Whitworth-Gewinde
Whitworth thread

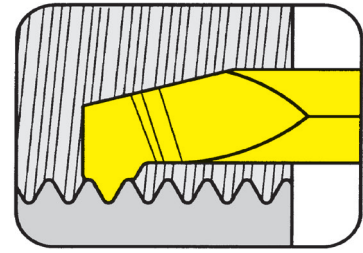

Bohrungs-Ø ab Gang pro Zoll	Bore Ø from Threads per inch	6 mm 19-28
--------------------------------	---------------------------------	---------------

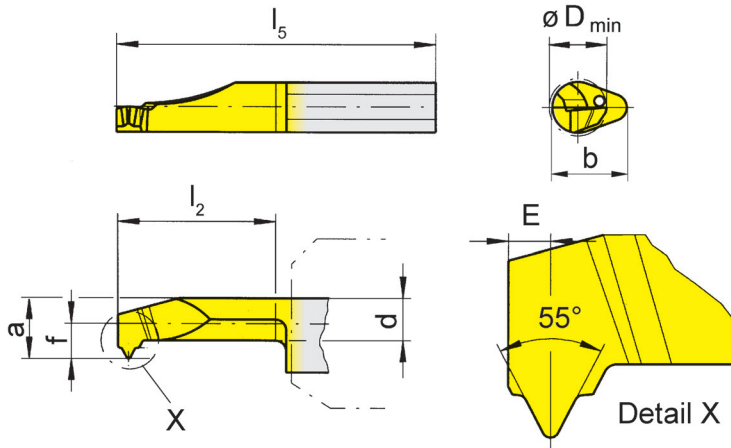

für Klemhalter
for Toolholder

Typ H105
Type HC105
B105/BU105
BKT
IR105
962
AIH
963
N

Gewinde BSW/BSF
Thread BSW/BSF

R = rechts wie gezeichnet
R = right hand version shown

L = links spiegelbildlich
L = left hand version

Bestellnummer Part number	TPI	E	f	a	d	b	l ₂	l ₅	D _{min}	EG35	TH35	TN35
R/L105.5519.2.6	19	1,0	3,3	5,7	3,7	7	15	30	6	▲/Δ	Δ/x	▲/▲
R105.5519.3.6	19	1,0	3,3	5,7	3,7	7	20	35	6	▲		▲
R/L105.5520.2.6	20	1,0	3,3	5,7	3,7	7	15	30	6	Δ/Δ		▲/Δ
R/L105.5522.2.6	22	1,0	3,3	5,7	3,7	7	15	30	6	Δ/Δ		Δ/Δ
R105.5522.3.6	22	1,0	3,3	5,7	3,7	7	20	35	6	Δ		Δ
R/L105.5524.2.6	24	0,8	3,3	5,7	3,7	7	15	30	6	Δ/Δ		Δ/Δ
R105.5524.3.6	24	0,8	3,3	5,7	3,7	7	20	35	6	Δ		Δ
R/L105.5526.2.6	26	0,8	3,3	5,7	3,7	7	15	30	6	Δ/Δ		▲/Δ
R105.5526.3.6	26	0,8	3,3	5,7	3,7	7	20	35	6	Δ		Δ
R/L105.5528.2.6	28	0,8	3,3	5,7	3,7	7	15	30	6	▲/Δ		▲/Δ
R/L105.5528.3.6	28	0,8	3,3	5,7	3,7	7	20	35	6	▲/Δ		▲/Δ

▲ ab Lager / on stock Δ 4 Wochen / 4 weeks x auf Anfrage / upon request

● empfohlen / recommended

o bedingt einsetzbar / alternative recommendation

- nicht geeignet / not suitable

■ unbeschichtete HM-Sorten / uncoated grades

■ beschichtete HM-Sorten / coated grades

■ bestückt/Cermet / brazed/Cermet

Abmessungen in mm

Dimensions in mm

Ausführung R oder L angeben

State R or L version

Weitere Abmessungen auf Anfrage

Further sizes upon request

P	●	●	●
M	●	●	●
K	○	●	●
N	-	●	●
S	-	●	●
H	-	-	-

HM-Sorten
Carbide grades

Gewindedrehen (innen) Teilprofil

Threading (internal) Partial profile



Schneidplatte

105

Insert

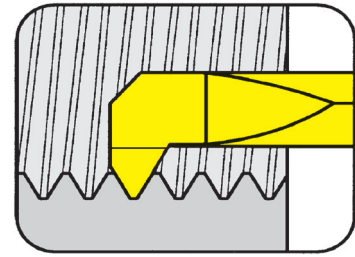

Bohrungs-Ø ab
Gang pro Zoll

Bore Ø from
Threads per inch

6 mm
18-27

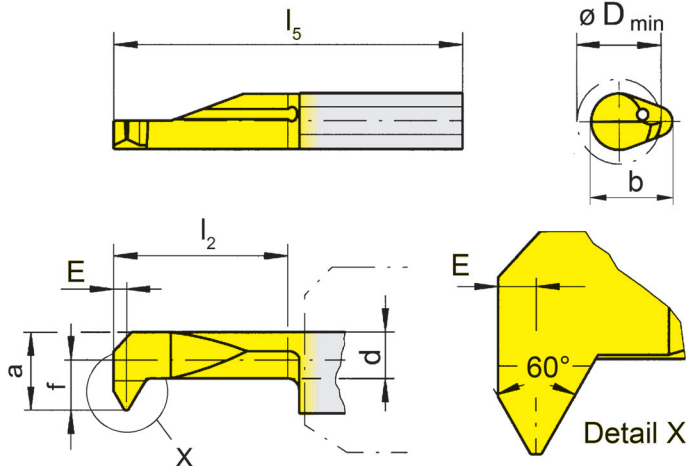

für Klemhalter
for Toolholder

Typ H105
Type HC105
B105/BU105
BKT
IR105
962
AIH
963
N

Gewinde NPT / NPTF
Thread NPT / NPTF

R = rechts wie gezeichnet
R = right hand version shown

L = links spiegelbildlich
L = left hand version

Bestellnummer Part number	TPI	E	f	a	d	b	l ₂	l ₅	D _{min}	HM-Sorten / Carbide grades				
										MG12	EG35	TH35	T125	TN35
R/L105.NP18.2.6	18	1,0	3,3	5,7	3,7	7	15	30	6	Δ/Δ	▲/Δ	▲/Δ	Δ/Δ	▲/▲
R/L105.NP18.3.6	18	1,0	3,3	5,7	3,7	7	20	35	6		Δ/Δ	▲/Δ		▲/Δ
R/L105.NP18.4.6	18	1,0	3,3	5,7	3,7	7	25	40	6		Δ/Δ	Δ/Δ		▲/Δ
R/L105.NP27.2.6	27	0,8	3,3	5,7	3,7	7	15	30	6		▲/Δ		▲/Δ	▲/▲
R/L105.NP27.3.6	27	0,8	3,3	5,7	3,7	7	20	35	6		Δ/Δ	Δ/Δ	Δ/Δ	Δ/Δ
R/L105.NP27.4.6	27	0,8	3,3	5,7	3,7	7	25	40	6		Δ/Δ	Δ/Δ		Δ/Δ

▲ ab Lager / on stock Δ 4 Wochen / 4 weeks x auf Anfrage / upon request

● empfohlen / recommended

o bedingt einsetzbar / alternative recommendation

- nicht geeignet / not suitable

■ unbeschichtete HM-Sorten / uncoated grades

■ beschichtete HM-Sorten / coated grades

■ bestückt/Cermet / brazed/Cermet

Abmessungen in mm

Dimensions in mm

Ausführung R oder L angeben

State R or L version

Weitere Abmessungen auf Anfrage

Further sizes upon request

P	o	•	•	•	•
M	-	•	•	•	•
K	-	o	•	•	•
N	-	-	•	•	•
S	-	-	•	•	•
H	-	-	-	-	-

HM-Sorten
Carbide grades

Schneidplatte Insert

105

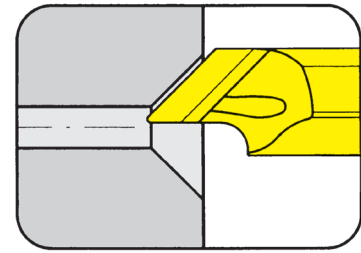

Faswinkel
Fasenbreite bis

Angle of chamfer
Width of chamfer up to

45°/60°
4 mm

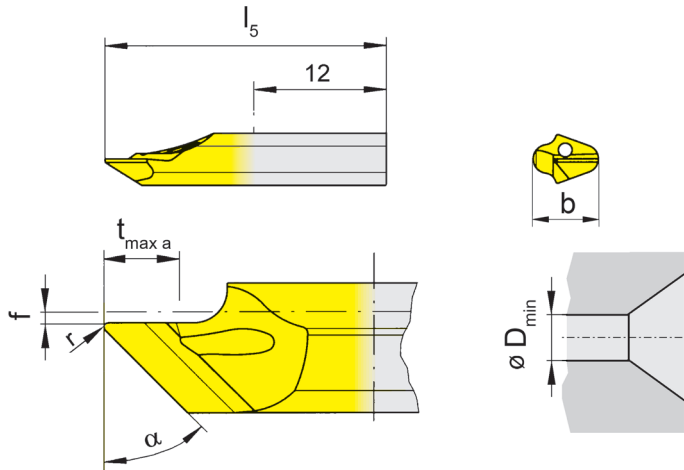

für Klemmhalter
for Toolholder

Typ H105
Type HC105
B105/BU105
BKT
IR105
962
AIH
963
N

R = rechts wie gezeichnet
R = right hand version shown

L = links spiegelbildlich
L = left hand version

Bestellnummer Part number	r	f	b	l ₅	t _{max a}	D _{min}	α	EG35	TF45	TI25	TN35
R/L105.0045.0.1	0,2	0,5	5,9	20	3,5	1	45°	▲/▲	▲/▲		▲/▲
R/L105.0045.1.1	0,2	0,5	5,9	25	3,5	1	45°	▲/▲	▲/▲	Δ/Δ	
R/L105.0060.0.1	0,2	0,5	5,9	20	4,0	1	60°	▲/▲	▲/▲		
R/L105.0060.1.1	0,2	0,5	5,9	25	4,0	1	60°	▲/▲	▲/▲	Δ/Δ	

▲ ab Lager / on stock Δ 4 Wochen / 4 weeks x auf Anfrage / upon request

● empfohlen / recommended

o bedingt einsetzbar / alternative recommendation

- nicht geeignet / not suitable

■ unbeschichtete HM-Sorten / uncoated grades

■ beschichtete HM-Sorten / coated grades

■ bestückt/Cermet / brazed/Cermet

Abmessungen in mm

Dimensions in mm

Ausführung R oder L angeben

State R or L version

Weitere Abmessungen auf Anfrage

Further sizes upon request

P	•	•	•	•
M	•	•	•	•
K	o	•	•	•
N	-	•	•	•
S	-	•	•	•
H	-	-	-	-

HM-Sorten
Carbide grades

Axialeinstechen

Face Grooving

Schneidplatte

Insert

105

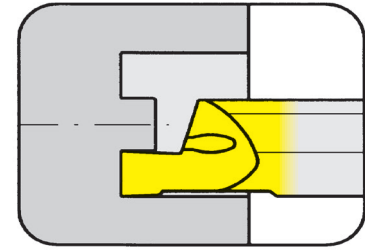

Nutaußen-Ø ab	from outer groove Ø	5 mm
Stechtiefe	Depth of groove	5 mm
Stechbreite bis	Width of groove up to	2 mm

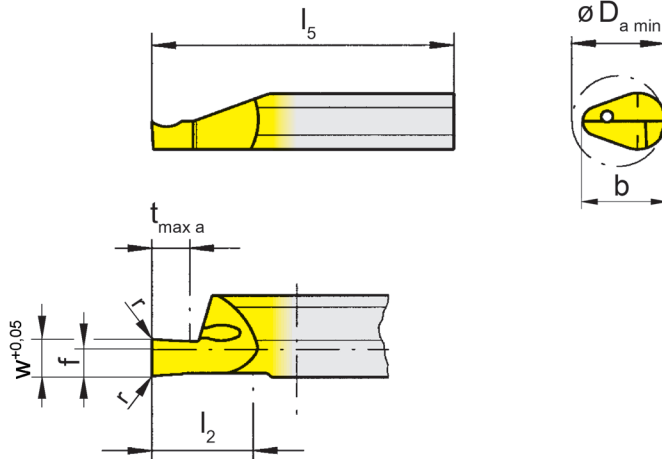

für Klemmhalter
for Toolholder

Typ H105
Type HC105
B105/BU105
BKT
IR105
962
AIH
963
N

R = rechts wie gezeichnet
R = right hand version shown

L = links spiegelbildlich
L = left hand version

Bestellnummer Part number	w	r	f	b	l ₂	l ₅	t _{max a}	D _{a min}	MG12	AN25	EG35	ES15	TI25
R105.0505.1.8	0,5	-	2	7	10	25	2	5		Δ	Δ	▲	
R/L105.0510.1.8	1,0	0,05	2	7	10	25	2	5	▲/▲		▲/▲		▲/▲
R/L105.0510.2.8	1,0	0,05	2	7	15	35	2	5	Δ/Δ		▲/Δ		▲/▲
R/L105.0515.1.8	1,5	0,05	2	7	10	25	3	5	▲/▲		▲/▲		▲/▲
R/L105.0515.2.8	1,5	0,05	2	7	15	35	3	5	Δ/Δ		▲/▲		▲/▲
R/L105.0520.1.8	2,0	0,05	2	7	10	25	5	5	▲/Δ		▲/▲		▲/▲
R/L105.0520.2.8	2,0	0,05	2	7	15	35	5	5	Δ/Δ		▲/▲		▲/▲

▲ ab Lager / on stock Δ 4 Wochen / 4 weeks x auf Anfrage / upon request

● empfohlen / recommended

o bedingt einsetzbar / alternative recommendation

- nicht geeignet / not suitable

■ unbeschichtete HM-Sorten / uncoated grades

■ beschichtete HM-Sorten / coated grades

■ bestückt/Cermet / brazed/Cermet

Abmessungen in mm

Dimensions in mm

Ausführung R oder L angeben

State R or L version

Weitere Abmessungen auf Anfrage

Further sizes upon request

P	o	●	●	●	●
M	-	o	●	o	●
K	-	-	o	●	●
N	-	-	-	-	●
S	-	-	-	-	●
H	-	-	-	-	-

HM-Sorten
Carbide grades

Axialeinstechen

Face Grooving



A

Schneidplatte

Insert

105

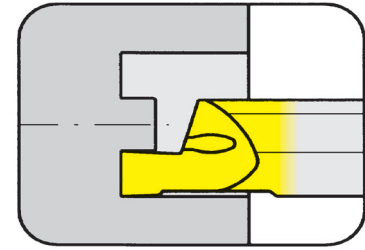

Nutaußen-Ø ab	from outer groove Ø	6 mm
Stechtiefe	Depth of groove	5 mm
Stechbreite bis	Width of groove up to	2 mm

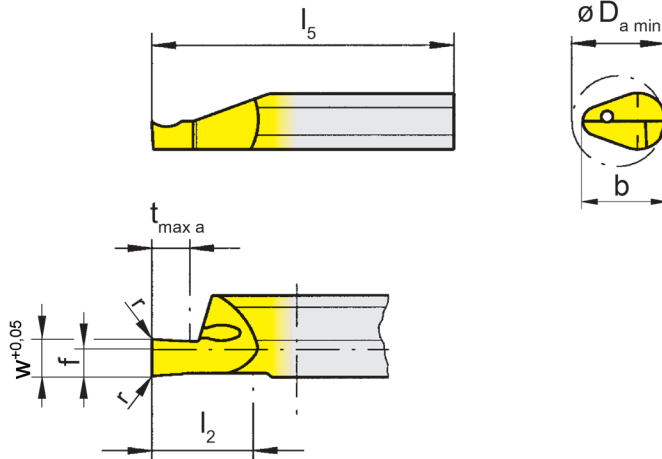

für Klemhalter
for Toolholder

Typ H105
Type HC105
B105/BU105
BKT
IR105
962
AIH
963
N

R = rechts wie gezeichnet
R = right hand version shown

L = links spiegelbildlich
L = left hand version

Bestellnummer Part number	w	r	f	b	l ₂	l ₅	t _{max a}	D _{a min}	MG12	EG35	TI25
R/L105.0610.1.8	1,0	0,05	2	7	10	25	2	6	▲/▲	▲/▲	▲/▲
R/L105.0610.2.8	1,0	0,05	2	7	15	35	2	6	▲/▲	▲/▲	▲/▲
R/L105.0615.1.8	1,5	0,05	2	7	10	25	3	6	▲/▲	▲/▲	▲/▲
R/L105.0615.2.8	1,5	0,05	2	7	15	35	3	6	▲/▲	▲/▲	▲/▲
R/L105.0620.1.8	2,0	0,05	2	7	10	25	5	6	▲/▲	▲/▲	▲/▲
R/L105.0620.2.8	2,0	0,05	2	7	15	35	5	6	▲/▲	▲/▲	▲/▲

▲ ab Lager / on stock Δ 4 Wochen / 4 weeks x auf Anfrage / upon request

● empfohlen / recommended

o bedingt einsetzbar / alternative recommendation

- nicht geeignet / not suitable

■ unbeschichtete HM-Sorten / uncoated grades

■ beschichtete HM-Sorten / coated grades

■ bestückt/Cermet / brazed/Cermet

Abmessungen in mm

Dimensions in mm

Ausführung R oder L angeben

State R or L version

Weitere Abmessungen auf Anfrage

Further sizes upon request

P	o	•	•
M	-	•	•
K	-	o	•
N	-	-	•
S	-	-	•
H	-	-	-

HM-Sorten
Carbide grades

Axialeinstechen

Face Grooving

Schneidplatte

Insert

105

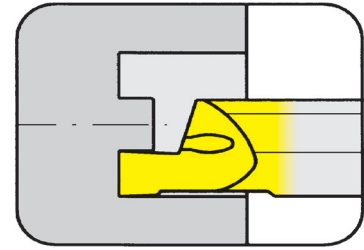

Nutaußen-Ø ab	from outer groove Ø	8 mm
Stechtiefe	Depth of groove	6 mm
Stechbreite bis	Width of groove up to	3 mm

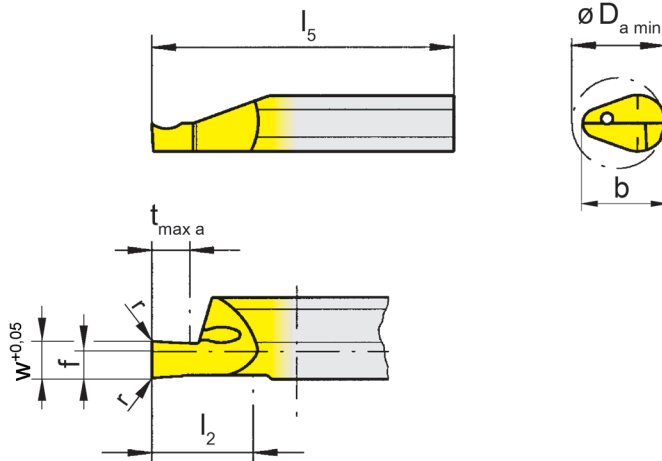

für Klemhalter
for Toolholder

Typ	H105
Type	HC105 B105/BU105 BKT IR105 962 AIH 963 N

R = rechts wie gezeichnet
R = right hand version shown

L = links spiegelbildlich
L = left hand version

Bestellnummer Part number	w	r	f	b	l ₂	l ₅	t _{max a}	D _{a min}	EG35	T125
R/L105.0810.1.8	1,0	0,15	2	7	10	25	2	8	▲/▲	▲/▲
R/L105.0810.2.8	1,0	0,15	2	7	15	35	2	8	▲/▲	▲/▲
R/L105.0815.1.8	1,5	0,15	2	7	10	25	3	8	▲/▲	▲/▲
R/L105.0815.2.8	1,5	0,15	2	7	15	35	3	8	▲/▲	▲/▲
R/L105.0820.1.8	2,0	0,15	2	7	10	25	4	8	▲/▲	▲/▲
R/L105.0820.2.8	2,0	0,15	2	7	15	35	4	8	▲/▲	▲/▲
R/L105.0825.1.8	2,5	0,15	2	7	10	25	5	8	▲/▲	▲/▲
R/L105.0825.2.8	2,5	0,15	2	7	15	35	5	8	▲/▲	▲/▲
R/L105.0830.1.8	3,0	0,15	2	7	10	25	6	8	▲/▲	▲/▲
R/L105.0830.2.8	3,0	0,15	2	7	15	35	6	8	▲/▲	▲/▲

▲ ab Lager / on stock Δ 4 Wochen / 4 weeks x auf Anfrage / upon request

● empfohlen / recommended

o bedingt einsetzbar / alternative recommendation

- nicht geeignet / not suitable

■ unbeschichtete HM-Sorten / uncoated grades

■ beschichtete HM-Sorten / coated grades

■ bestückt/Cermet / brazed/Cermet

Abmessungen in mm

Dimensions in mm

Ausführung R oder L angeben

State R or L version

Weitere Abmessungen auf Anfrage

Further sizes upon request

P	•	•
M	•	•
K	o	•
N	-	•
S	-	•
H	-	-

HM-Sorten
Carbide grades

Axialeinstechen

Face Grooving



A

Schneidplatte

Insert

105

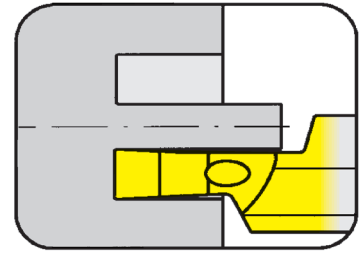

Nutaußen-Ø ab	from outer groove Ø	8 mm
Stechtiefe	Depth of groove	6 mm
Stechbreite bis	Width of groove up to	3 mm

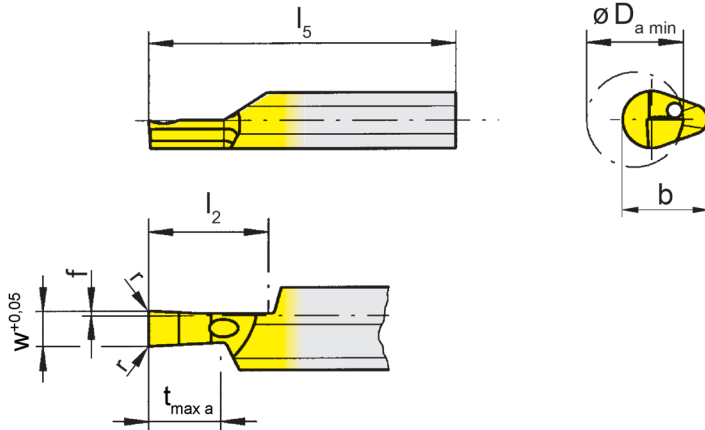

für Klemmhalter
for Toolholder

Typ H105
Type HC105
B105/BU105
BKT
IR105
962
AIH
963
N

R = rechts wie gezeichnet
R = right hand version shown

L = links spiegelbildlich
L = left hand version

Bestellnummer Part number	w	r	f	b	l ₂	l ₅	t _{max a}	D _{a min}	EG35	TI25
R/L105.0810.1.9	1,0	0,15	0,4	7	10	25	2	8	▲/▲	▲/▲
R/L105.0815.1.9	1,5	0,15	0,4	7	10	25	3	8	▲/▲	▲/▲
R/L105.0820.1.9	2,0	0,15	0,4	7	10	25	4	8	▲/▲	▲/▲
R/L105.0825.1.9	2,5	0,15	0,4	7	10	25	5	8	▲/▲	▲/▲
R/L105.0830.1.9	3,0	0,15	0,4	7	10	25	6	8	▲/▲	▲/▲

▲ ab Lager / on stock Δ 4 Wochen / 4 weeks x auf Anfrage / upon request

● empfohlen / recommended

o bedingt einsetzbar / alternative recommendation

- nicht geeignet / not suitable

■ unbeschichtete HM-Sorten / uncoated grades

■ beschichtete HM-Sorten / coated grades

■ bestückt/Cermet / brazed/Cermet

Abmessungen in mm

Dimensions in mm

Ausführung R oder L angeben

State R or L version

Weitere Abmessungen auf Anfrage

Further sizes upon request

P	•	•
M	•	•
K	o	•
N	-	•
S	-	•
H	-	-

HM-Sorten
Carbide grades

Axialeinstechen

Face Grooving



Schneidplatte

Insert

105

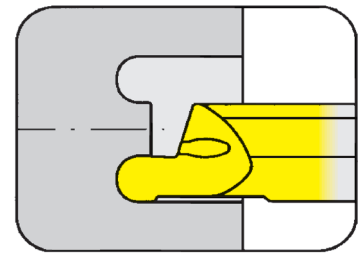

Nutaußen-Ø ab	from outer groove Ø	8 mm
Stechtiefe	Depth of groove	6 mm
Stechbreite bis	Width of groove up to	3 mm

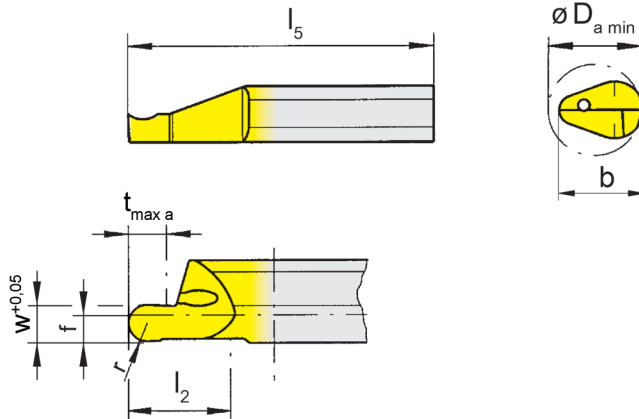

für Klemhalter
for Toolholder

Typ H105
Type HC105
B105/BU105
BKT
IR105
962
AIH
963
N

Vollradius
Full radius

R = rechts wie gezeichnet
R = right hand version shown

L = links spiegelbildlich
L = left hand version

Bestellnummer Part number	w	r	f	b	l ₂	l ₅	t _{max a}	D _{a min}	EG35	T125
R/L105.8V10.1.8	1,0	0,50	2	7	10	25	2	8	▲/▲	▲/▲
R/L105.8V10.2.8	1,0	0,50	2	7	15	35	2	8	▲/▲	▲/▲
R/L105.8V16.1.8	1,6	0,80	2	7	10	25	3	8	▲/▲	▲/▲
R/L105.8V16.2.8	1,6	0,80	2	7	15	35	3	8	▲/Δ	▲/▲
R/L105.8V20.1.8	2,0	1,00	2	7	10	25	4	8	▲/▲	▲/▲
R/L105.8V20.2.8	2,0	1,00	2	7	15	35	4	8	▲/▲	▲/▲
R/L105.8V25.1.8	2,5	1,25	2	7	10	25	5	8	▲/Δ	▲/▲
R/L105.8V25.2.8	2,5	1,25	2	7	15	35	5	8	▲/Δ	▲/Δ
R/L105.8V30.1.8	3,0	1,50	2	7	10	25	6	8	▲/▲	▲/▲
R/L105.8V30.2.8	3,0	1,50	2	7	15	35	6	8	▲/Δ	▲/▲

▲ ab Lager / on stock Δ 4 Wochen / 4 weeks x auf Anfrage / upon request

● empfohlen / recommended

o bedingt einsetzbar / alternative recommendation

- nicht geeignet / not suitable

■ unbeschichtete HM-Sorten / uncoated grades

■ beschichtete HM-Sorten / coated grades

■ bestückt/Cermet / brazed/Cermet

Abmessungen in mm

Dimensions in mm

Ausführung R oder L angeben

State R or L version

Weitere Abmessungen auf Anfrage

Further sizes upon request

P	•	•
M	•	•
K	o	•
N	-	•
S	-	•
H	-	-

HM-Sorten
Carbide grades

Vorstechen und Fasen (innen)

Pregrooving and Chamfering (internal)

Schneidplatte

Insert

105

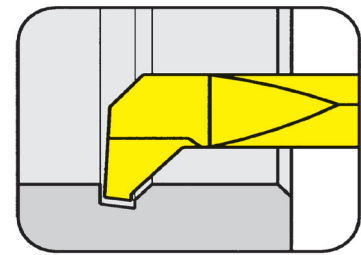

Bohrungs-Ø ab	Bore Ø from	3 mm
---------------	-------------	------

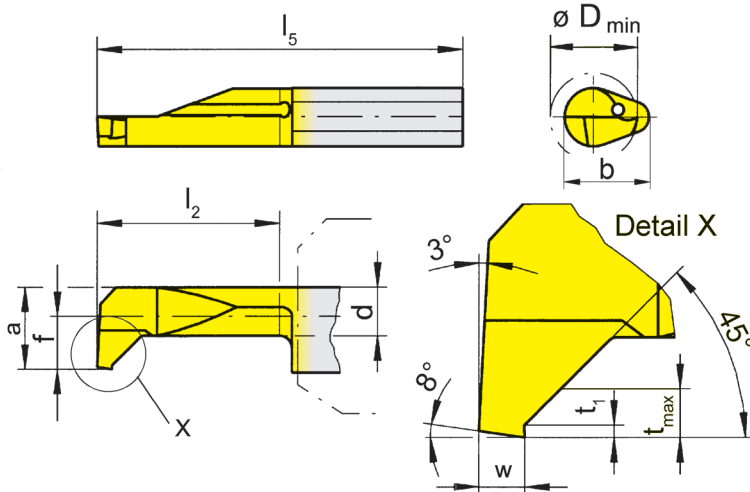

für Klemhalter
for Toolholder

Typ H105
Type HC105
B105/BU105
BKT
IR105
962
AIH
963
N

R = rechts wie gezeichnet
R = right hand version shown

L = links spiegelbildlich
L = left hand version

Bestellnummer Part number	w	f	a	d	b	l ₂	l ₅	t _{max}	t ₁	D _{min}	MG12	EG35	TI25	TN35
R/L105.0810.1.3	0,7	1,4	2,7	2,0	5,9	10	25	0,5	0,2	3		▲/▲		▲/▲
R/L105.0810.2.3	0,7	1,4	2,7	2,0	5,9	15	30	0,5	0,2	3		▲/▲		▲/▲
R/L105.0810.1.4	1,0	1,9	3,7	2,7	6,4	10	25	0,7	0,2	4		▲/▲		▲/▲
R/L105.0810.2.4	1,0	1,9	3,7	2,7	6,4	15	30	0,7	0,2	4		▲/▲		▲/▲
R/L105.0810.3.4	1,0	1,9	3,7	2,7	6,4	20	35	0,7	0,2	4		▲/▲		▲/▲
R/L105.0810.2.5	1,0	2,3	4,7	3,5	7,0	15	30	0,7	0,2	5	▲/▲	▲/▲		▲/▲
R/L105.0810.3.5	1,0	2,3	4,7	3,5	7,0	20	35	0,7	0,2	5		▲/▲	▲/▲	▲/▲
R/L105.0810.4.5	1,0	2,3	4,7	3,5	7,0	25	40	0,7	0,2	5		▲/▲	▲/▲	▲/▲
R/L105.0810.5.5	1,0	2,3	4,7	3,5	7,0	30	45	0,7	0,2	5		▲/▲	▲/▲	▲/▲
R/L105.0810.5.6	1,0	3,1	5,5	4,2	7,0	30	45	1,0	0,2	6		▲/▲		▲/▲
R/L105.0810.7.6	1,0	3,1	5,5	4,2	7,0	40	55	1,0	0,2	6		▲/▲		▲/▲

▲ ab Lager / on stock Δ 4 Wochen / 4 weeks x auf Anfrage / upon request

● empfohlen / recommended

o bedingt einsetzbar / alternative recommendation

- nicht geeignet / not suitable

■ unbeschichtete HM-Sorten / uncoated grades

■ beschichtete HM-Sorten / coated grades

■ bestückt/Cermet / brazed/Cermet

Abmessungen in mm

Dimensions in mm

Ausführung R oder L angeben

State R or L version

Weitere Abmessungen auf Anfrage

Further sizes upon request

P	o	•	•	•
M	-	•	•	•
K	-	o	•	•
N	-	-	•	•
S	-	-	•	•
H	-	-	-	-

HM-Sorten
Carbide grades

Platte

Insert

105

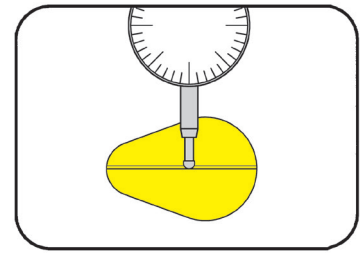

Platte zum Einrichten des Werkzeugs
Insert for tool set up

für Klemmhalter
for Toolholder

Typ H105
Type HC105
B105/BU105
BKT
IR105
962
AIH
963
N

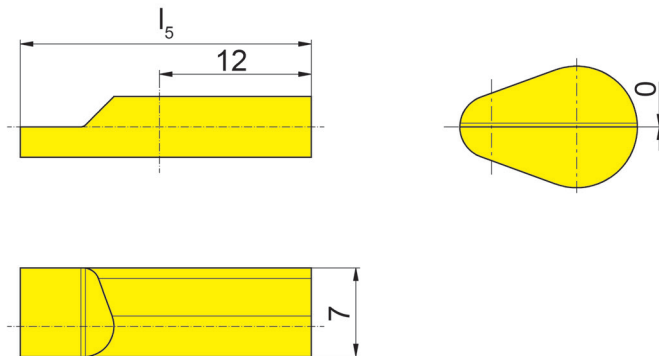

R = rechts wie gezeichnet
R = right hand version shown

Bestellnummer Part number	l_5
R105.LEHR.H.01	23

Abmessungen in mm
Dimensions in mm



Schneidplatte
Insert
105

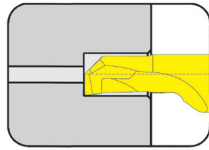

Seite/Page
A82

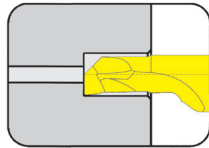

Seite/Page
A83

Technische Hinweise
Technical Instructions

Seite/Page
A84-A85

Supermini[®] HP



Multifunktionales Werkzeug

für hohe Schnitttiefen

Multifunctional Tool

for high cutting depths

Schneidplatte

Insert

105

für Stahl
for steel

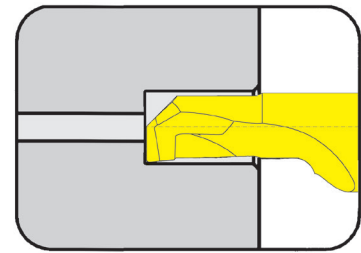

Schneidkreis-Ø ab

Cutting edge Ø from

3 mm

mit innerer Kühlmittelzufuhr ab Schneidkreisdurchmesser 5 mm
with through coolant supply from cutting diameter 5 mm

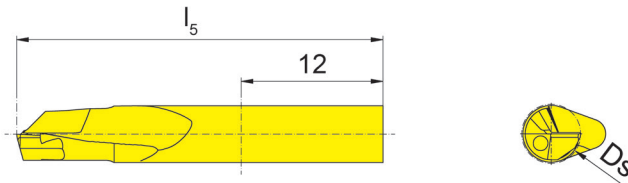

für Klemmhalter
for Toolholder

Typ B105
Type

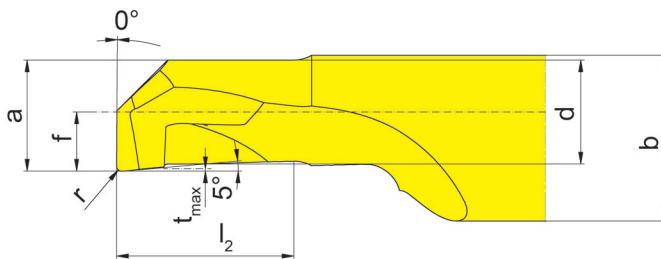

R = rechts wie gezeichnet
R = right hand version shown

L = links spiegelbildlich
L = left hand version

mit Spantreppe
with chip breaker

Bestellnummer Part number	r	f	a	d	b	l ₂	l ₅	t _{max}	Ds	EG35
R/L105.BO.30.20.045.1	0,2	1,5	2,7	2,4	7	4,5	31	0,1	3	▲/△
R/L105.BO.30.20.075.1	0,2	1,5	2,7	2,4	7	7,5	31	0,1	3	▲/△
R/L105.BO.40.20.060.1	0,2	2,0	3,7	3,4	7	6,0	31	0,1	4	▲/△
R/L105.BO.40.20.100.1	0,2	2,0	3,7	3,4	7	10,0	31	0,1	4	▲/△
R/L105.BO.50.20.075.1	0,2	2,5	4,7	4,4	7	7,5	31	0,1	5	▲/△
R/L105.BO.50.20.125.1	0,2	2,5	4,7	4,4	7	12,5	36	0,1	5	▲/△
R/L105.BO.60.20.090.1	0,2	3,0	5,4	5,1	7	9,0	31	0,1	6	▲/△
R/L105.BO.60.20.150.1	0,2	3,0	5,4	5,1	7	15,0	36	0,1	6	▲/△
R/L105.BO.70.20.105.1	0,2	3,5	5,9	5,6	7	10,5	36	0,1	7	▲/△
R/L105.BO.70.20.175.1	0,2	3,5	5,9	5,6	7	17,5	40	0,1	7	▲/△

▲ ab Lager / on stock △ 4 Wochen / 4 weeks x auf Anfrage / upon request

● empfohlen / recommended

o bedingt einsetzbar / alternative recommendation

- nicht geeignet / not suitable

■ unbeschichtete HM-Sorten / uncoated grades

■ beschichtete HM-Sorten / coated grades

■ bestückt/Cermet / brazed/Cermet

Abmessungen in mm

Dimensions in mm

P	•
M	•
K	o
N	-
S	-
H	-

HM-Sorten
Carbide grades

Schneidplatte

Insert

105

für rostfreien Stahl
for stainless steel

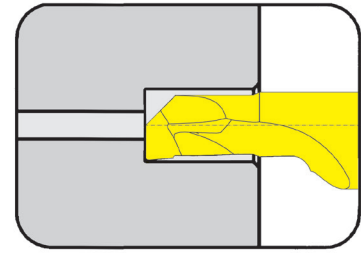

Schneidkreis-Ø ab	Cutting edge Ø from	3 mm
-------------------	---------------------	------

mit innerer Kühlmittelzufuhr ab Schneidkreisdurchmesser 5 mm
with through coolant supply from cutting diameter 5 mm

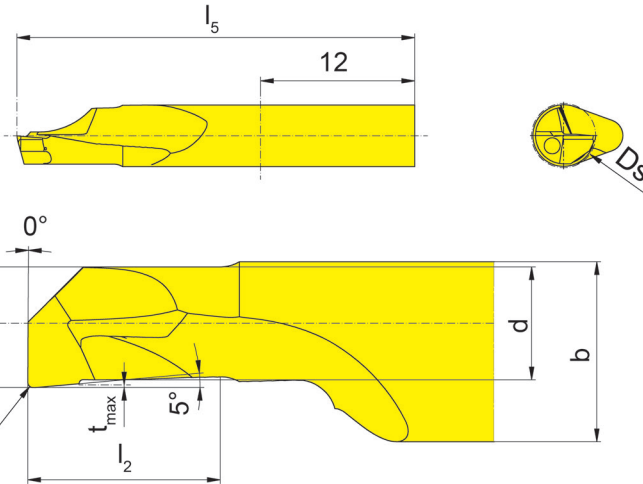

für Klemmhalter
for Toolholder

Typ B105
Type

Universalgeometrie
universal geometry

R = rechts wie gezeichnet
R = right hand version shown

L = links spiegelbildlich
L = left hand version

Bestellnummer Part number	r	f	a	d	b	l ₂	l ₅	t _{max}	Ds	EG35
R/L105.BO.30.20.045.2	0,2	1,5	2,7	2,4	7	4,5	31	0,1	3	▲/△
R/L105.BO.30.20.075.2	0,2	1,5	2,7	2,4	7	7,5	31	0,1	3	▲/△
R/L105.BO.40.20.060.2	0,2	2,0	3,7	3,4	7	6,0	31	0,1	4	▲/△
R/L105.BO.40.20.100.2	0,2	2,0	3,7	3,4	7	10,0	31	0,1	4	▲/△
R/L105.BO.50.20.075.2	0,2	2,5	4,7	4,4	7	7,5	31	0,1	5	▲/△
R/L105.BO.50.20.125.2	0,2	2,5	4,7	4,4	7	12,5	36	0,1	5	▲/△
R/L105.BO.60.20.090.2	0,2	3,0	5,4	5,1	7	9,0	31	0,1	6	▲/△
R/L105.BO.60.20.150.2	0,2	3,0	5,4	5,1	7	15,0	36	0,1	6	▲/△
R/L105.BO.70.20.105.2	0,2	3,5	5,9	5,6	7	10,5	36	0,1	7	▲/△
R/L105.BO.70.20.175.2	0,2	3,5	5,9	5,6	7	17,5	40	0,1	7	▲/△

▲ ab Lager / on stock Δ 4 Wochen / 4 weeks x auf Anfrage / upon request

● empfohlen / recommended

o bedingt einsetzbar / alternative recommendation

- nicht geeignet / not suitable

■ unbeschichtete HM-Sorten / uncoated grades

■ beschichtete HM-Sorten / coated grades

■ bestückt/Cermet / brazed/Cermet

Abmessungen in mm

Dimensions in mm

P	•
M	•
K	o
N	-
S	-
H	-

HM-Sorten
Carbide grades

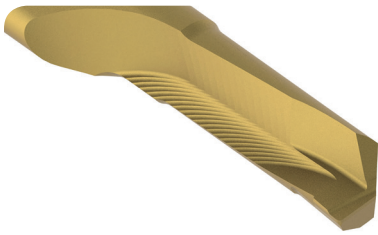

Geometrie mit Spantreppe für bessere Spankontrolle

- Ausdrehen mit großen Zustellungen
- Für allgemeine Stähle
- Mit Schleppschnede für höhere Vorschübe
- Bessere Spankontrolle
- Bohren in allgemeinen Stählen
- Bei problematischen Anwendungen mit dem Ziel Prozesssicherheit
- Auch bei langspanenden Werkstoffen

Geometry with chipbreaker for better chip control

- Turning with large infeeds
- For general steels
- With trailing cutting edge for higher feeds
- Better chip control
- Drilling in general steels
- For problematic applications with the aim of process reliability
- Also for long-chipping materials

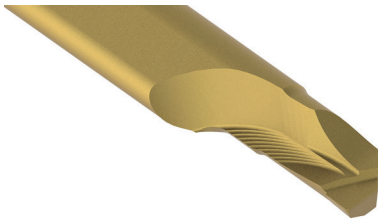

Universalgeometrie

- Ausdrehen mit großen Zustellungen
- Leichtschneidende Universalgeometrie auch für rostfreie Stähle
- Mit Schleppschnede für höhere Vorschübe
- Weniger Schnittdruck, auch für dünnwandige Bauteile
- Zum Bohren in Stahl und NE-Metallen

Universal geometry

- Turning with large infeeds
- Easy cutting universal geometry also for stainless steels
- With trailing cutting edge for higher feeds
- Less cutting pressure, suitable even for thin-walled components
- For drilling in steel and non-ferrous metals

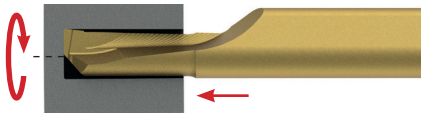

Bohren ins Volle mit ebenem Bohrungsgrund
Drilling into the solid and achieving a flat hole bottom

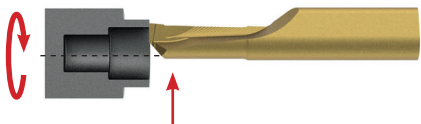

Drehen von Plankonturen
Turning of face profiles

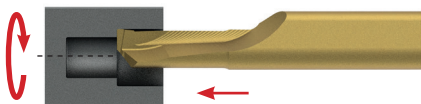

Drehen von Innenkonturen
Turning of internal profiles

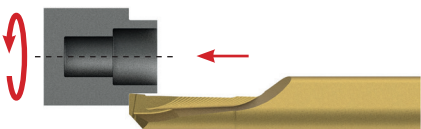

Drehen von Außenkonturen
Turning of external profiles

Ausdrehen Stahl Boring Steel		Schnitttiefe ap (mm) Depth of cut ap (mm)					
		0,5	1	1,5	2	2,5	3
		Vorschub f [mm/U] Feed rate f [mm/rev]					
R/L105.BO.30.20.045.1	1,5*D	0,03-0,05	0,02-0,03				
R/L105.BO.30.20.075.1	2,5*D	0,03-0,05	0,02-0,03				
R/L105.BO.40.20.060.1	1,5*D	0,04-0,06	0,04-0,06	0,04-0,06			
R/L105.BO.40.20.100.1	2,5*D	0,04-0,06	0,04-0,06	0,04-0,06			
R/L105.BO.50.20.075.1	1,5*D	0,05-0,08	0,05-0,08	0,04-0,07	0,04-0,07		
R/L105.BO.50.20.125.1	2,5*D	0,05-0,08	0,05-0,08	0,04-0,07	0,04-0,07		
R/L105.BO.60.20.090.1	1,5*D	0,07-0,1	0,07-0,1	0,07-0,1	0,07-0,1	0,05-0,08	
R/L105.BO.60.20.150.1	2,5*D	0,07-0,1	0,07-0,1	0,07-0,1	0,07-0,1	0,05-0,08	
R/L105.BO.70.20.105.1	1,5*D	0,08-0,1	0,07-0,1	0,07-0,1	0,07-0,1	0,07-0,08	0,05-0,07
R/L105.BO.70.20.175.1	2,5*D	0,08-0,1	0,07-0,1	0,07-0,1	0,07-0,1	0,07-0,08	0,05-0,07

Vorschubwerte für rostfreie Materialien: Minimal-Werte wählen.
Feed rates for stainless materials: Select minimum values.

Bohren Stahl Drilling Steel		Vorschub f [mm/U] Feed rate f [mm/rev]
R/L105.BO.30.20.045.2	1,5*D	0,01-0,02
R/L105.BO.30.20.075.2	2,5*D	0,01-0,02
R/L105.BO.40.20.060.2	1,5*D	0,01-0,02
R/L105.BO.40.20.100.2	2,5*D	0,01-0,02
R/L105.BO.50.20.075.2	1,5*D	0,02-0,04
R/L105.BO.50.20.125.2	2,5*D	0,02-0,04
R/L105.BO.60.20.090.2	1,5*D	0,03-0,05
R/L105.BO.60.20.150.2	2,5*D	0,03-0,05
R/L105.BO.70.20.105.2	1,5*D	0,03-0,05
R/L105.BO.70.20.175.2	2,5*D	0,03-0,05

Zum Bohren empfehlen wir die Universalgeometrie
For drilling we recommend the universal geometry

Schnittgeschwindigkeit: siehe Kapitel „Technische Hinweise“.
Cutting speed: please see chapter „Technical Instructions“.

Weitere Informationen finden Sie in unserem Katalog „STECHDREHEN“.

Further information on face grooving can be found in our catalogue „GROOVING“.

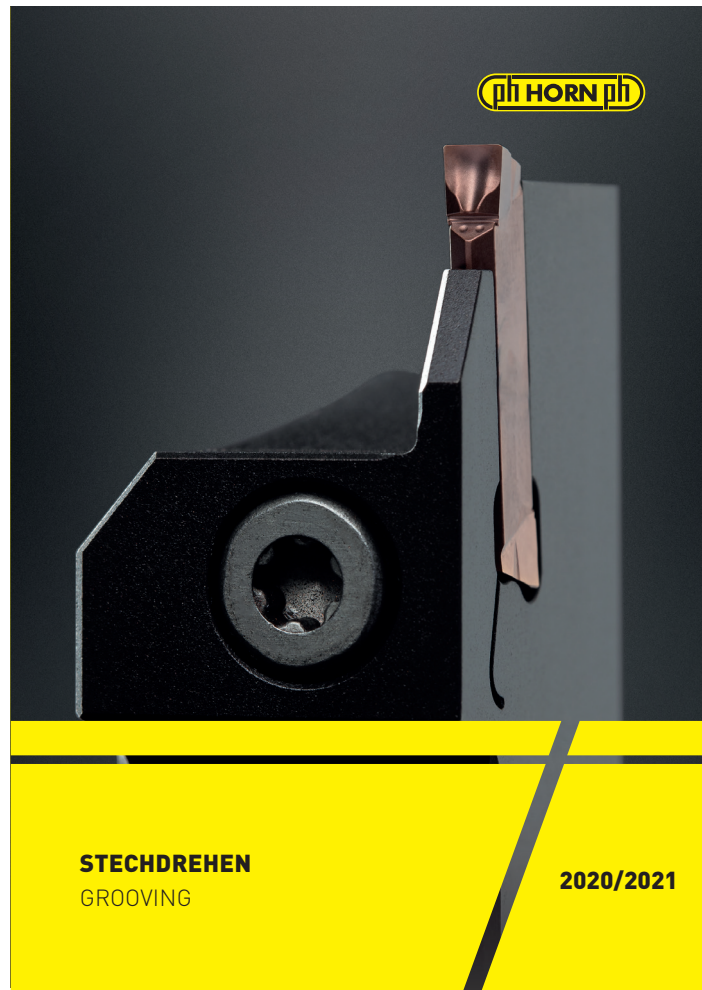

109



**Klemmhalter mit
Schneidplatten**

Stechbreite 1 - 2 mm

**Toolholder with
Inserts**

Width of groove 1 - 2 mm

Klemmhalter
Toolholder
B109

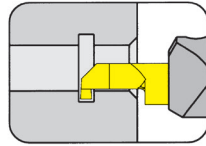

Seite/Page
A89-A90

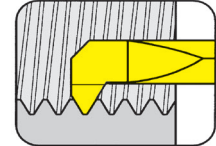

Seite/Page
A100

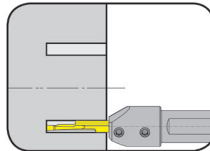

Seite/Page
A103

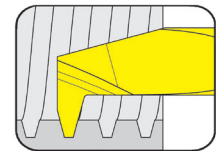

Seite/Page
A101

Schneidplatte
Insert
109/A109

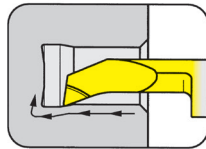

Seite/Page
A91-A92

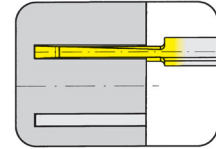

Seite/Page
A104

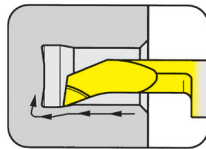

Seite/Page
A93-A94

Platte
Insert
109

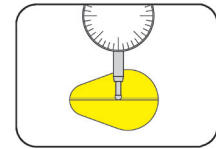

Seite/Page
A102

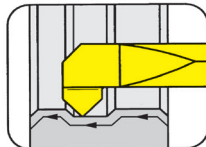

Seite/Page
A95

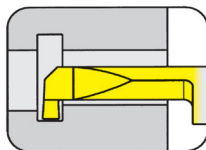

Seite/Page
A96-A97

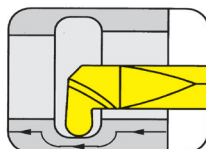

Seite/Page
A98

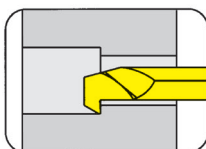

Seite/Page
A99

Einstechen und Ausdrehen

Grooving and Boring



Klemmhalter

Toolholder

B109

mit innerer Kühlmittelzufuhr
with through coolant supply

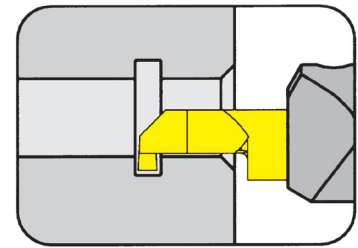

Bohrungs-Ø ab Stechtiefe bis Stechbreite bis	Bore Ø from Depth of groove up to Width of groove up to	6 mm 2,5 mm 2 mm
--	---	------------------------

für Schneidplatte
for Insert

Typ 109
Type



Abbildung = rechtsschneidend
Picture = right hand cutting version

Bestellnummer Part number	d	l ₁	h	l ₄	l ₂	d ₂
B109.0012.01	12	75	10	50	16	20
B109.0016.01	16	75	14	50	16	20
B109.0020.01	20	90	18	55	-	20
B109.0025.01	25	100	23	55	-	25

Weitere Abmessungen auf Anfrage
Further sizes upon request

Abmessungen in mm
Dimensions in mm

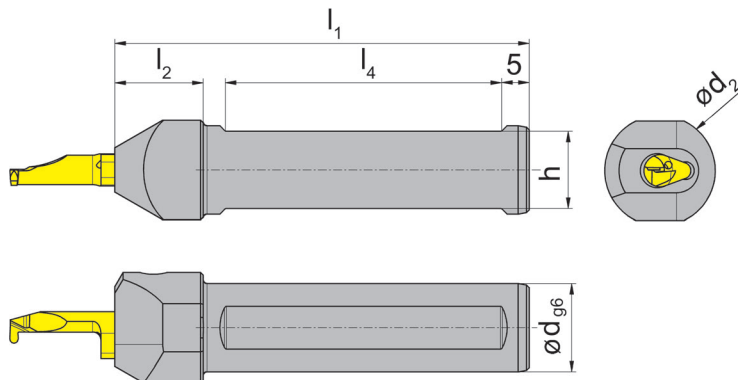
Bestellhinweis:

Klemmhalter sind jeweils für rechte und linke Schneidplatten verwendbar.

Ordering note:

Toolholders can be used with right and left hand inserts.

Das Anzugsdrehmoment der Schrauben finden Sie in den Technischen Hinweisen.

For torque specification of the screw, please see Technical Instructions.

Ersatzteile

Spare parts

Klemmhalter Toolholder	Spannschraube Clamping Screw	TORX PLUS®-Schlüssel TORX PLUS® Wrench
B109...	6.075T15P	T15PQ

Einstechen und Ausdrehen

Grooving and Boring



Klemmhalter

Toolholder

B109

mit innerer Kühlmittelzufuhr
with through coolant supply

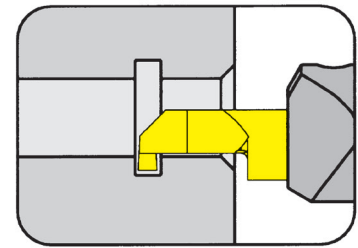

Bohrungs-Ø ab
Stechtiefe
Stechbreite bis

Bore Ø from
Depth of groove
Width of groove up to

6 mm
2,5 mm
2 mm

A

für Schneidplatte
for Insert

Typ 109
Type



Abbildung = rechtsschneidend
Picture = right hand cutting version

Bestellnummer Part number	d	l ₁	h	l ₂
B109.0022.1.2.01	22	120	20	72

Weitere Abmessungen auf Anfrage
Further sizes upon request

Abmessungen in mm
Dimensions in mm

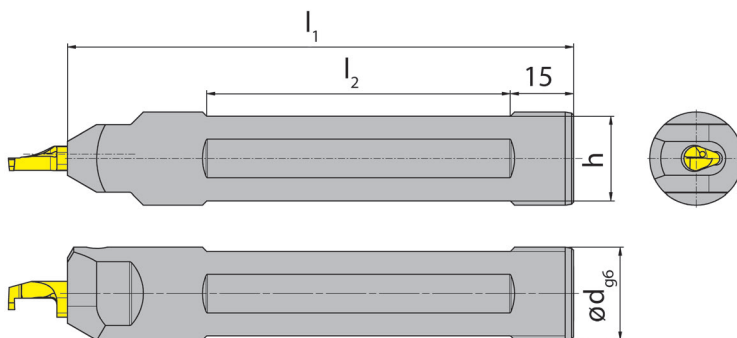
Bestellhinweis:

Klemmhalter sind jeweils für rechte und linke Schneidplatten verwendbar.

Ordering note:

Toolholders can be used with right and left hand inserts.

Das Anzugsdrehmoment der Schrauben finden Sie in den Technischen Hinweisen.

For torque specification of the screw, please see Technical Instructions.

Ersatzteile

Spare parts

Klemmhalter Toolholder	Spannschraube Clamping Screw	TORX PLUS®-Schlüssel TORX PLUS® Wrench
B109.0022.1.2.01	6.075T15P	T15PQ

Schneidplatte

Insert

109

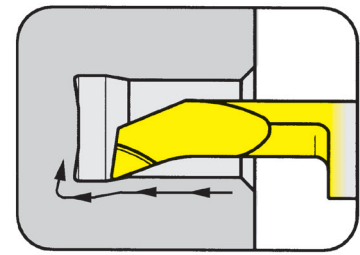

A

Bohrungs-Ø ab Bore Ø from 6 mm

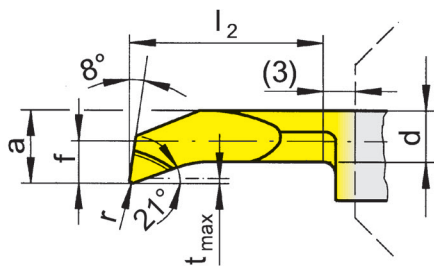
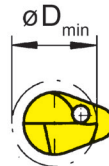
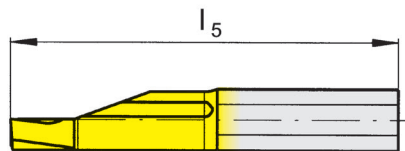

für Klemmhalter
for Toolholder

Typ B109
Type

R = rechts wie gezeichnet
R = right hand version shown

L = links spiegelbildlich
L = left hand version

Bestellnummer Part number	r	f	a	d	l ₂	l ₅	t _{max}	D _{min}	TH35
R/L109.1828.04.1.6	0,4	2,8	5,7	5	10	28	0,4	6	Δ/Δ
R/L109.1828.04.2.6	0,4	2,8	5,7	5	15	33	0,4	6	Δ/Δ
R/L109.1828.04.3.6	0,4	2,8	5,7	5	20	38	0,4	6	Δ/Δ
R/L109.1828.04.4.6	0,4	2,8	5,7	5	25	43	0,4	6	Δ/Δ
R/L109.1828.04.5.6	0,4	2,8	5,7	5	30	48	0,4	6	Δ/Δ
R/L109.1828.04.6.6	0,4	2,8	5,7	5	35	53	0,4	6	Δ/Δ
R/L109.1828.04.7.6	0,4	2,8	5,7	5	40	58	0,4	6	Δ/Δ
R/L109.1838.04.2.7	0,4	3,8	6,7	6	15	33	0,4	7	Δ/Δ
R/L109.1838.04.3.7	0,4	3,8	6,7	6	20	38	0,4	7	Δ/Δ
R/L109.1838.04.4.7	0,4	3,8	6,7	6	25	43	0,4	7	Δ/Δ
R/L109.1838.04.5.7	0,4	3,8	6,7	6	30	48	0,4	7	Δ/Δ
R/L109.1838.04.6.7	0,4	3,8	6,7	6	35	53	0,4	7	Δ/Δ
R/L109.1838.04.7.7	0,4	3,8	6,7	6	40	58	0,4	7	▲/Δ
R/L109.1838.04.8.7	0,4	3,8	6,7	6	45	63	0,4	7	▲/Δ

- ▲ ab Lager / on stock Δ 4 Wochen / 4 weeks x auf Anfrage / upon request
- empfohlen / recommended
- o bedingt einsetzbar / alternative recommendation
- nicht geeignet / not suitable
- unbeschichtete HM-Sorten / uncoated grades
- beschichtete HM-Sorten / coated grades
- bestückt/Cermet / brazed/Cermet

P	•
M	•
K	•
N	•
S	•
H	-

Abmessungen in mm
Dimensions in mm

HM-Sorten
Carbide grades

Ausführung R oder L angeben
State R or L version

Weitere Abmessungen auf Anfrage
Further sizes upon request

Schneidplatte

Insert

109

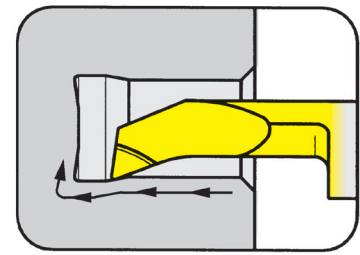

Bohrungs-Ø ab	Bore Ø from	6 mm
---------------	-------------	------

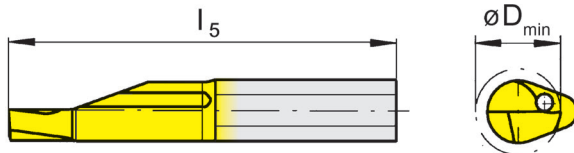

für Klemhalter
for Toolholder

Typ B109
Type

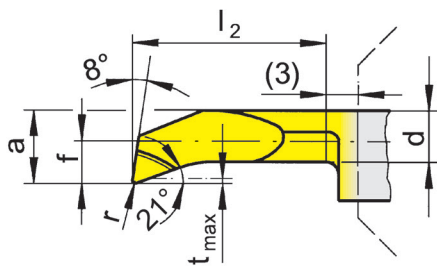

R = rechts wie gezeichnet
R = right hand version shown

L = links spiegelbildlich
L = left hand version

Bestellnummer Part number	r	f	a	d	l ₂	l ₅	t _{max}	D _{min}	TH35
R/L109.1828.1.6	0,2	2,8	5,7	5	10	28	0,4	6	Δ/Δ
R/L109.1828.2.6	0,2	2,8	5,7	5	15	33	0,4	6	Δ/Δ
R/L109.1828.3.6	0,2	2,8	5,7	5	20	38	0,4	6	▲/Δ
R/L109.1828.4.6	0,2	2,8	5,7	5	25	43	0,4	6	Δ/Δ
R/L109.1828.5.6	0,2	2,8	5,7	5	30	48	0,4	6	Δ/Δ
R/L109.1828.6.6	0,2	2,8	5,7	5	35	53	0,4	6	Δ/Δ
R/L109.1828.7.6	0,2	2,8	5,7	5	40	58	0,4	6	▲/Δ
R/L109.1838.2.7	0,2	3,8	6,7	6	15	33	0,4	7	Δ/Δ
R/L109.1838.3.7	0,2	3,8	6,7	6	20	38	0,4	7	Δ/Δ
R/L109.1838.4.7	0,2	3,8	6,7	6	25	43	0,4	7	Δ/Δ
R/L109.1838.5.7	0,2	3,8	6,7	6	30	48	0,4	7	▲/Δ
R/L109.1838.6.7	0,2	3,8	6,7	6	35	53	0,4	7	▲/Δ
R/L109.1838.7.7	0,2	3,8	6,7	6	40	58	0,4	7	▲/Δ
R/L109.1838.8.7	0,2	3,8	6,7	6	45	63	0,4	7	▲/Δ

- ▲ ab Lager / on stock Δ 4 Wochen / 4 weeks x auf Anfrage / upon request
- empfohlen / recommended
- o bedingt einsetzbar / alternative recommendation
- nicht geeignet / not suitable
- unbeschichtete HM-Sorten / uncoated grades
- beschichtete HM-Sorten / coated grades
- bestückt/Cermet / brazed/Cermet

P	•
M	•
K	•
N	•
S	•
H	-

HM-Sorten
Carbide grades

Abmessungen in mm
Dimensions in mm

Ausführung R oder L angeben
State R or L version

Weitere Abmessungen auf Anfrage
Further sizes upon request

Schneidplatte

Insert

109

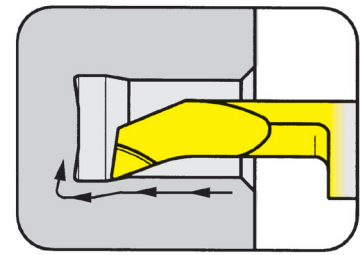

A

Bohrungs-Ø ab Bore Ø from 6 mm

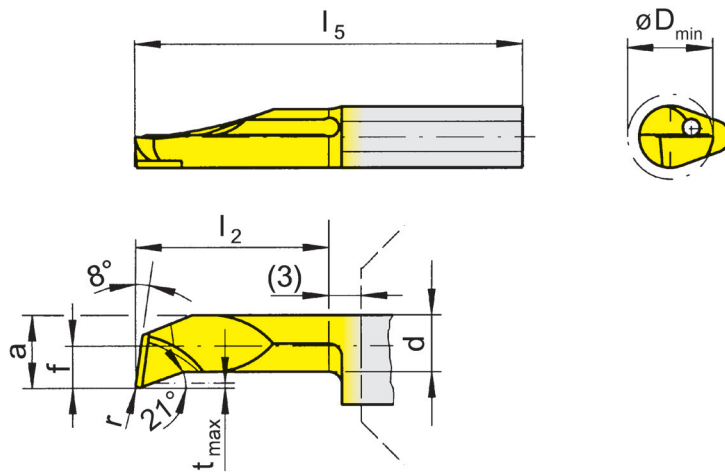

für Klemhalter
for Toolholder

Typ B109
Type

R = rechts wie gezeichnet
R = right hand version shown

L = links spiegelbildlich
L = left hand version

verlängerte Spantreppe
(Geometrie HV)
extended chip breaker
(geometry HV)

Bestellnummer Part number	r	f	a	d	l ₂	l ₅	t _{max}	D _{min}	TH35
R/L109.1828.1.HV6	0,2	2,8	5,7	5	10	28	0,4	6	ΔΔ
R/L109.1828.2.HV6	0,2	2,8	5,7	5	15	33	0,4	6	ΔΔ
R/L109.1828.3.HV6	0,2	2,8	5,7	5	20	38	0,4	6	ΔΔ
R/L109.1828.4.HV6	0,2	2,8	5,7	5	25	43	0,4	6	ΔΔ
R/L109.1828.5.HV6	0,2	2,8	5,7	5	30	48	0,4	6	▲/Δ
R/L109.1828.6.HV6	0,2	2,8	5,7	5	35	53	0,4	6	▲/Δ
R/L109.1828.7.HV6	0,2	2,8	5,7	5	40	58	0,4	6	▲/Δ
R/L109.1838.2.HV7	0,2	3,8	6,7	6	15	33	0,4	7	ΔΔ
R/L109.1838.3.HV7	0,2	3,8	6,7	6	20	38	0,4	7	ΔΔ
R/L109.1838.4.HV7	0,2	3,8	6,7	6	25	43	0,4	7	ΔΔ
R/L109.1838.5.HV7	0,2	3,8	6,7	6	30	48	0,4	7	ΔΔ
R/L109.1838.6.HV7	0,2	3,8	6,7	6	35	53	0,4	7	ΔΔ
R/L109.1838.7.HV7	0,2	3,8	6,7	6	40	58	0,4	7	ΔΔ
R/L109.1838.8.HV7	0,2	3,8	6,7	6	45	63	0,4	7	ΔΔ

- ▲ ab Lager / on stock Δ 4 Wochen / 4 weeks x auf Anfrage / upon request
- empfohlen / recommended
- o bedingt einsetzbar / alternative recommendation
- nicht geeignet / not suitable
- unbeschichtete HM-Sorten / uncoated grades
- beschichtete HM-Sorten / coated grades
- bestückt/Cermet / brazed/Cermet

P	•
M	•
K	•
N	•
S	•
H	-

Abmessungen in mm
Dimensions in mm

HM-Sorten
Carbide grades

Ausführung R oder L angeben
State R or L version

Weitere Abmessungen auf Anfrage
Further sizes upon request

Schneidplatte

Insert

109

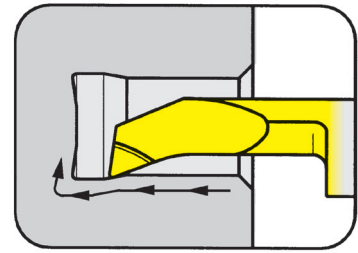

Bohrungs-Ø ab	Bore Ø from	6 mm
---------------	-------------	------

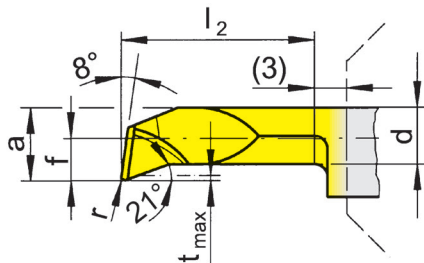
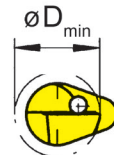
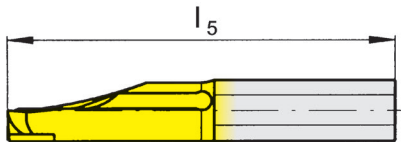

für Klemmhalter
for Toolholder

Typ B109
Type

verlängerte Spantreppe
(Geometrie HV)
extended chip breaker
(geometry HV)

R = rechts wie gezeichnet
R = right hand version shown

L = links spiegelbildlich
L = left hand version

Bestellnummer Part number	r	f	a	d	l ₂	l ₅	t _{max}	D _{min}	TH35
R/L109.1828.04.1.HV6	0,4	2,8	5,7	5	10	28	0,4	6	ΔΔ
R/L109.1828.04.2.HV6	0,4	2,8	5,7	5	15	33	0,4	6	ΔΔ
R/L109.1828.04.3.HV6	0,4	2,8	5,7	5	20	38	0,4	6	ΔΔ
R/L109.1828.04.4.HV6	0,4	2,8	5,7	5	25	43	0,4	6	ΔΔ
R/L109.1828.04.5.HV6	0,4	2,8	5,7	5	30	48	0,4	6	ΔΔ
R/L109.1828.04.6.HV6	0,4	2,8	5,7	5	35	53	0,4	6	ΔΔ
R/L109.1828.04.7.HV6	0,4	2,8	5,7	5	40	58	0,4	6	ΔΔ
R/L109.1838.04.2.HV7	0,4	3,8	6,7	6	15	33	0,4	7	ΔΔ
R/L109.1838.04.3.HV7	0,4	3,8	6,7	6	20	38	0,4	7	ΔΔ
R/L109.1838.04.4.HV7	0,4	3,8	6,7	6	25	43	0,4	7	ΔΔ
R/L109.1838.04.5.HV7	0,4	3,8	6,7	6	30	48	0,4	7	ΔΔ
R/L109.1838.04.6.HV7	0,4	3,8	6,7	6	35	53	0,4	7	ΔΔ
R/L109.1838.04.7.HV7	0,4	3,8	6,7	6	40	58	0,4	7	ΔΔ
R/L109.1838.04.8.HV7	0,4	3,8	6,7	6	45	63	0,4	7	▲/Δ

- ▲ ab Lager / on stock Δ 4 Wochen / 4 weeks x auf Anfrage / upon request
- empfohlen / recommended
- o bedingt einsetzbar / alternative recommendation
- nicht geeignet / not suitable
- unbeschichtete HM-Sorten / uncoated grades
- beschichtete HM-Sorten / coated grades
- bestückt/Cermet / brazed/Cermet

P	•
M	•
K	•
N	•
S	•
H	-

Abmessungen in mm
Dimensions in mm

Ausführung R oder L angeben
State R or L version

Weitere Abmessungen auf Anfrage
Further sizes upon request

HM-Sorten
Carbide grades

Schneidplatte

Insert

109

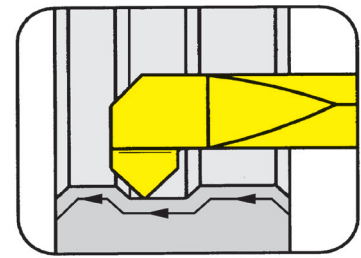

A

Bohrungs-Ø ab	Bore Ø from	6 mm
---------------	-------------	------

für Klemmhalter
for Toolholder

Typ B109
Type

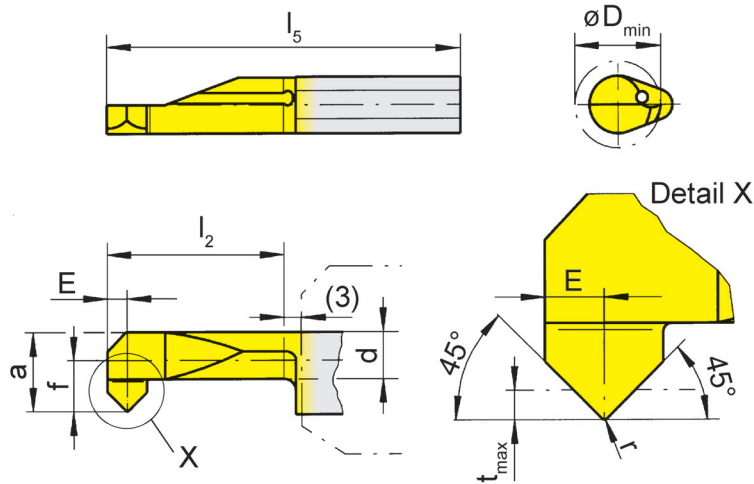

R = rechts wie gezeichnet
R = right hand version shown

L = links spiegelbildlich
L = left hand version

Bestellnummer Part number	r	f	E	a	d	l ₂	l ₅	t _{max}	D _{min}	TH35
R/L109.4545.3.6	0,2	2,8	1,2	5,7	4,3	20	38	0,9	6	Δ/Δ
R/L109.4545.5.7	0,2	3,8	1,2	6,7	5,3	30	48	0,9	7	▲/▲

- ▲ ab Lager / on stock Δ 4 Wochen / 4 weeks x auf Anfrage / upon request
- empfohlen / recommended
- o bedingt einsetzbar / alternative recommendation
- nicht geeignet / not suitable
- unbeschichtete HM-Sorten / uncoated grades
- beschichtete HM-Sorten / coated grades
- bestückt/Cermet / brazed/Cermet

P	•
M	•
K	•
N	•
S	•
H	-

HM-Sorten
Carbide grades

Abmessungen in mm
Dimensions in mm

Ausführung R oder L angeben
State R or L version

Weitere Abmessungen auf Anfrage
Further sizes upon request

Einstecken (innen)

Grooving (internal)



Schneidplatte

Insert

109

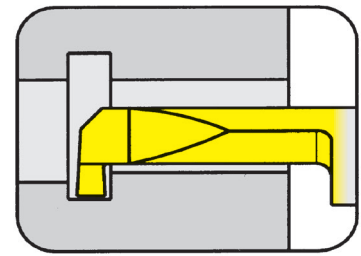

Bohrungs-Ø ab
Stechtiefe bis

Bore Ø from
Depth of groove up to

6 mm
1,8 mm

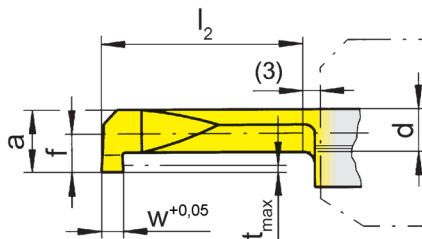
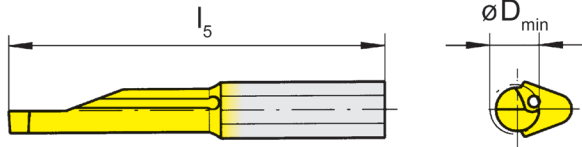

für Klemmhalter
for Toolholder

Typ B109
Type

R = rechts wie gezeichnet
R = right hand version shown

L = links spiegelbildlich
L = left hand version

Bestellnummer Part number	w	f	a	d	l ₂	l ₅	t _{max}	D _{min}	TH35
R/L109.0100.1.6	1,0	2,8	5,7	3,7	10	28	1,8	6	ΔΔ
R/L109.0100.2.6	1,0	2,8	5,7	3,7	15	33	1,8	6	ΔΔ
R/L109.0100.3.6	1,0	2,8	5,7	3,7	20	38	1,8	6	ΔΔ
R/L109.0100.4.6	1,0	2,8	5,7	3,7	25	43	1,8	6	ΔΔ
R/L109.0100.5.6	1,0	2,8	5,7	3,7	30	48	1,8	6	ΔΔ
R/L109.0100.6.6	1,0	2,8	5,7	3,7	35	53	1,8	6	ΔΔ
R/L109.0150.1.6	1,5	2,8	5,7	3,7	10	28	1,8	6	ΔΔ
R/L109.0150.2.6	1,5	2,8	5,7	3,7	15	33	1,8	6	ΔΔ
R/L109.0150.3.6	1,5	2,8	5,7	3,7	20	38	1,8	6	ΔΔ
R/L109.0150.4.6	1,5	2,8	5,7	3,7	25	43	1,8	6	ΔΔ
R/L109.0150.5.6	1,5	2,8	5,7	3,7	30	48	1,8	6	ΔΔ
R/L109.0150.6.6	1,5	2,8	5,7	3,7	35	53	1,8	6	ΔΔ
R/L109.0200.1.6	2,0	2,8	5,7	3,7	10	28	1,8	6	ΔΔ
R/L109.0200.2.6	2,0	2,8	5,7	3,7	15	33	1,8	6	ΔΔ
R/L109.0200.3.6	2,0	2,8	5,7	3,7	20	38	1,8	6	ΔΔ
R/L109.0200.4.6	2,0	2,8	5,7	3,7	25	43	1,8	6	ΔΔ
R/L109.0200.5.6	2,0	2,8	5,7	3,7	30	48	1,8	6	ΔΔ
R/L109.0200.6.6	2,0	2,8	5,7	3,7	35	53	1,8	6	▲/Δ

▲ ab Lager / on stock Δ 4 Wochen / 4 weeks x auf Anfrage / upon request

● empfohlen / recommended

○ bedingt einsetzbar / alternative recommendation

- nicht geeignet / not suitable

■ unbeschichtete HM-Sorten / uncoated grades

■ beschichtete HM-Sorten / coated grades

■ bestückt/Cermet / brazed/Cermet

P	•
M	•
K	•
N	•
S	•
H	-

Abmessungen in mm
Dimensions in mm

Ausführung R oder L angeben
State R or L version

HM-Sorten
Carbide grades

Einstechen (innen)

Grooving (internal)



Schneidplatte

Insert

109

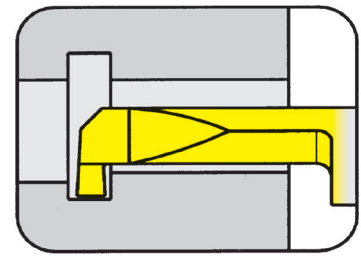

Bohrungs-Ø ab Stechtiefe bis	Bore Ø from Depth of groove up to	7 mm 2,5 mm
---------------------------------	--------------------------------------	----------------

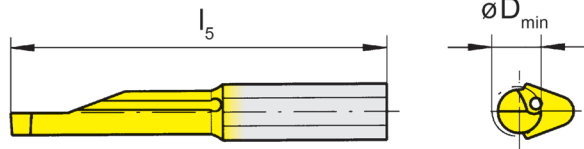

für Klemhalter
for Toolholder

Typ B109
Type

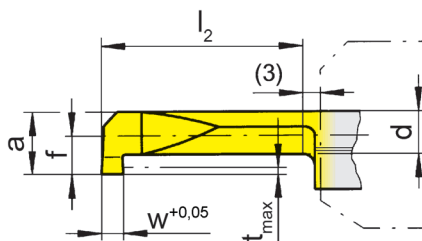

R = rechts wie gezeichnet
R = right hand version shown

L = links spiegelbildlich
L = left hand version

Bestellnummer Part number	w	f	a	d	l ₂	l ₅	t _{max}	D _{min}	TH35
R/L109.0100.1.7	1,0	3,8	6,7	4	10	28	2,5	7	Δ/Δ
R/L109.0100.2.7	1,0	3,8	6,7	4	15	33	2,5	7	Δ/Δ
R/L109.0100.3.7	1,0	3,8	6,7	4	20	38	2,5	7	Δ/Δ
R/L109.0100.4.7	1,0	3,8	6,7	4	25	43	2,5	7	Δ/Δ
R/L109.0100.5.7	1,0	3,8	6,7	4	30	48	2,5	7	Δ/▲
R/L109.0100.6.7	1,0	3,8	6,7	4	35	53	2,5	7	Δ/Δ
R/L109.0150.1.7	1,5	3,8	6,7	4	10	28	2,5	7	Δ/Δ
R/L109.0150.2.7	1,5	3,8	6,7	4	15	33	2,5	7	▲/Δ
R/L109.0150.3.7	1,5	3,8	6,7	4	20	38	2,5	7	Δ/Δ
R/L109.0150.4.7	1,5	3,8	6,7	4	25	43	2,5	7	Δ/Δ
R/L109.0150.5.7	1,5	3,8	6,7	4	30	48	2,5	7	Δ/Δ
R/L109.0150.6.7	1,5	3,8	6,7	4	35	53	2,5	7	Δ/Δ
R/L109.0200.1.7	2,0	3,8	6,7	4	10	28	2,5	7	▲/Δ
R/L109.0200.2.7	2,0	3,8	6,7	4	15	33	2,5	7	▲/Δ
R/L109.0200.3.7	2,0	3,8	6,7	4	20	38	2,5	7	Δ/Δ
R/L109.0200.4.7	2,0	3,8	6,7	4	25	43	2,5	7	Δ/Δ
R/L109.0200.5.7	2,0	3,8	6,7	4	30	48	2,5	7	▲/Δ
R/L109.0200.6.7	2,0	3,8	6,7	4	35	53	2,5	7	▲/Δ

▲ ab Lager / on stock Δ 4 Wochen / 4 weeks x auf Anfrage / upon request

● empfohlen / recommended

○ bedingt einsetzbar / alternative recommendation

- nicht geeignet / not suitable

■ unbeschichtete HM-Sorten / uncoated grades

■ beschichtete HM-Sorten / coated grades

■ bestückt/Cermet / brazed/Cermet

P	•
M	•
K	•
N	•
S	•
H	-

Abmessungen in mm
Dimensions in mm

Ausführung R oder L angeben
State R or L version

HM-Sorten
Carbide grades

Einstecken (innen)

Grooving (internal)



Schneidplatte

Insert

109

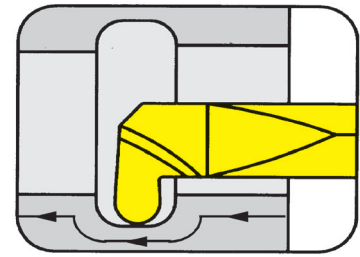

Bohrungs-Ø ab
Vollradius

Bore Ø from
Full radius

6 mm
0,5-1 mm

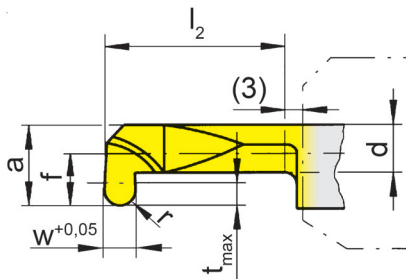
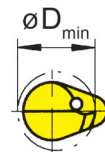
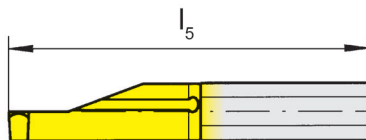

für Klemmhalter
for Toolholder

Typ B109
Type

Vollradius
Full radius

R = rechts wie gezeichnet
R = right hand version shown

L = links spiegelbildlich
L = left hand version

Bestellnummer Part number	w	r	f	a	d	l ₂	l ₅	t _{max}	D _{min}	TH35
R/L109.0005.4.6	1,0	0,50	2,8	5,7	3,7	25	43	1,8	6	Δ/Δ
R/L109.0005.6.7	1,0	0,50	3,8	6,7	4,0	35	53	2,5	7	Δ/Δ
R/L109.0007.4.6	1,5	0,75	2,8	5,7	3,7	25	43	1,8	6	Δ/Δ
R/L109.0007.6.7	1,5	0,75	3,8	6,7	4,0	35	53	2,5	7	Δ/Δ
R/L109.0010.4.6	2,0	1,00	2,8	5,7	3,7	25	43	1,8	6	Δ/Δ
R/L109.0010.6.7	2,0	1,00	3,8	6,7	4,0	35	53	2,5	7	▲/Δ

▲ ab Lager / on stock Δ 4 Wochen / 4 weeks x auf Anfrage / upon request

● empfohlen / recommended

o bedingt einsetzbar / alternative recommendation

- nicht geeignet / not suitable

□ unbeschichtete HM-Sorten / uncoated grades

■ beschichtete HM-Sorten / coated grades

■ bestückt/Cermet / brazed/Cermet

Abmessungen in mm

Dimensions in mm

Ausführung R oder L angeben

State R or L version

Weitere Abmessungen auf Anfrage

Further sizes upon request

P	•
M	•
K	•
N	•
S	•
H	-

HM-Sorten
Carbide grades

Rückwärtsdrehen (innen)

Backboring (internal)



Schneidplatte

109

Insert

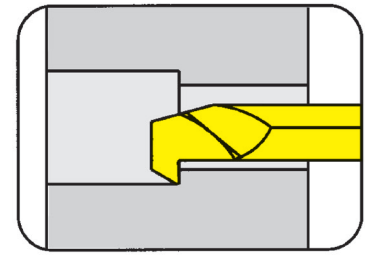

Bohrungs-Ø ab	Bore Ø from	6 mm
---------------	-------------	------

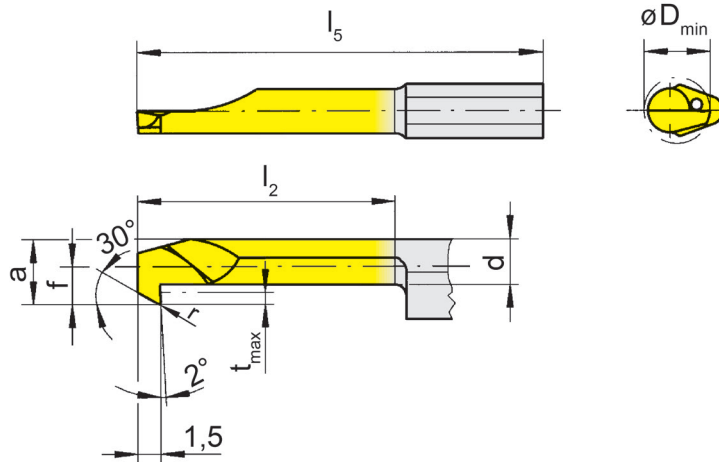

für Klemhalter
for Toolholder

Typ B109
Type

R = rechts wie gezeichnet
R = right hand version shown

L = links spiegelbildlich
L = left hand version

Bestellnummer Part number	r	f	a	d	l ₂	l ₅	t _{max}	D _{min}	TH35
R/L109.3028.3.6	0,2	2,8	5,7	3,7	20	38	1,8	6	Δ/Δ
R/L109.3028.5.6	0,2	2,8	5,7	3,7	30	48	1,8	6	Δ/Δ
R/L109.3038.3.7	0,2	3,8	6,7	4,0	20	38	2,5	7	▲/Δ
R/L109.3038.5.7	0,2	3,8	6,7	4,0	30	48	2,5	7	▲/Δ

▲ ab Lager / on stock Δ 4 Wochen / 4 weeks x auf Anfrage / upon request

● empfohlen / recommended

o bedingt einsetzbar / alternative recommendation

- nicht geeignet / not suitable

□ unbeschichtete HM-Sorten / uncoated grades

■ beschichtete HM-Sorten / coated grades

■ bestückt/Cermet / brazed/Cermet

Abmessungen in mm

Dimensions in mm

Ausführung R oder L angeben

State R or L version

Weitere Abmessungen auf Anfrage

Further sizes upon request

P	•
M	•
K	•
N	•
S	•
H	-

HM-Sorten
Carbide grades



Gewindedrehen (innen) Teilprofil

Threading (internal) Partial profile



Schneidplatte

109

Insert

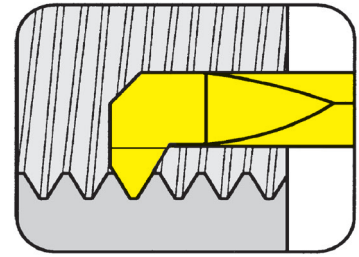

Bohrungs-Ø ab Steigung

Bore Ø from Pitch

7 mm
1,5-1,75 mm

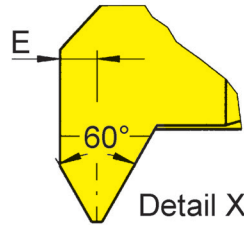
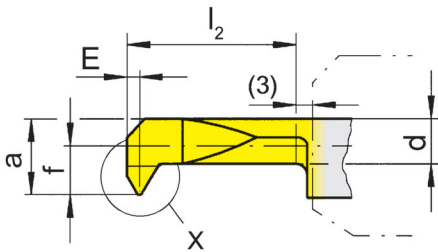
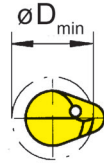
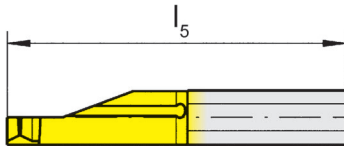

für Klemmhalter
for Toolholder

Typ B109
Type

Metrisches ISO-Gewinde
Metric ISO-thread

R = rechts wie gezeichnet
R = right hand version shown

L = links spiegelbildlich
L = left hand version

Bestellnummer Part number	P	P _{max}	E	f	a	d	l ₂	l ₅	D _{min}	TH35
R/L109.0815.1.7	1,5	1,75	0,9	3,8	6,7	5,1	10	28	7	Δ/Δ
R/L109.0815.3.7	1,5	1,75	0,9	3,8	6,7	5,1	20	38	7	▲/Δ
R/L109.0815.5.7	1,5	1,75	0,9	3,8	6,7	5,1	30	48	7	▲/Δ

▲ ab Lager / on stock Δ 4 Wochen / 4 weeks x auf Anfrage / upon request

● empfohlen / recommended

o bedingt einsetzbar / alternative recommendation

- nicht geeignet / not suitable

■ unbeschichtete HM-Sorten / uncoated grades

■ beschichtete HM-Sorten / coated grades

■ bestückt/Cermet / brazed/Cermet

Abmessungen in mm

Dimensions in mm

Ausführung R oder L angeben

State R or L version

Weitere Abmessungen auf Anfrage

Further sizes upon request

P	•
M	•
K	•
N	•
S	•
H	-

HM-Sorten
Carbide grades

Gewindedrehen (innen) Teilprofil

Threading (internal) Partial profile



Schneidplatte

109

Insert

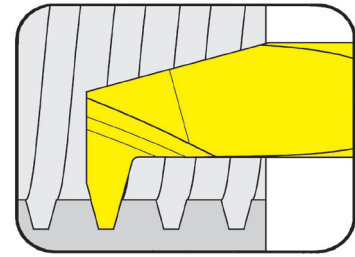

Bohrungs-Ø ab Steigung	Bore Ø from Pitch	6 mm 1,5-3 mm
------------------------	-------------------	------------------



für Klemmhalter
for Toolholder

Typ B109
Type

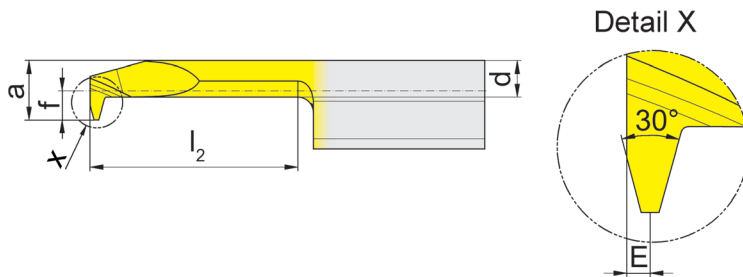

Metrisches ISO
Trapezgewinde DIN 103
Metric ISO trapezoidal thread
DIN 103

R = rechts wie gezeichnet
R = right hand version shown

Bestellnummer Part number	P	E	f	a	d	l ₂	l ₅	D _{min}		TH35
R109.0915.3.6	1,5	0,6	2,8	5,7	3,5	20	38	6		▲
R109.1220.3.6	2,0	0,8	2,8	5,7	3,5	20	38	6		▲
R109.1220.3.7	2,0	0,8	3,8	6,7	4,8	20	38	7		▲
R109.1220.5.7	2,0	0,8	3,8	6,7	4,8	30	48	7		▲
R109.1730.3.7	3,0	1,2	3,8	6,7	4,3	20	38	7		▲

▲ ab Lager / on stock Δ 4 Wochen / 4 weeks x auf Anfrage / upon request

● empfohlen / recommended

o bedingt einsetzbar / alternative recommendation

- nicht geeignet / not suitable

□ unbeschichtete HM-Sorten / uncoated grades

■ beschichtete HM-Sorten / coated grades

■ bestückt/Cermet / brazed/Cermet

Abmessungen in mm

Dimensions in mm

Weitere Abmessungen auf Anfrage

Further sizes upon request

P	•
M	•
K	•
N	•
S	•
H	-

HM-Sorten
Carbide grades

Platte

Insert

109

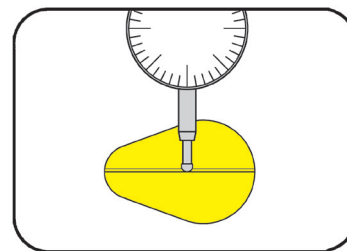

Platte zum Einrichten des Werkzeugs
 Platte zum Einrichten des Werkzeugs

für Klemmhalter
 for Toolholder

Typ B109
 Type

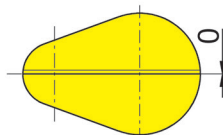
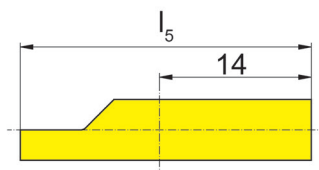

R = rechts wie gezeichnet
 R = right hand version shown

L = links spiegelbildlich
 L = left hand version

Bestellnummer Part number	l_5
L109.LEHR.H.01 MG12	28

Abmessungen in mm
 Dimensions in mm
 Ausführung R oder L angeben
 State R or L version

A

Axialeinstechen

Face Grooving



Klemmhalter

Toolholder

B109

mit innerer Kühlmittelzufuhr
with through coolant supply

Nutaußen-Ø ab	from outer groove Ø	15 mm
Stechtiefe	Depth of groove	20 mm
Stechbreite	Width of groove	2-3 mm

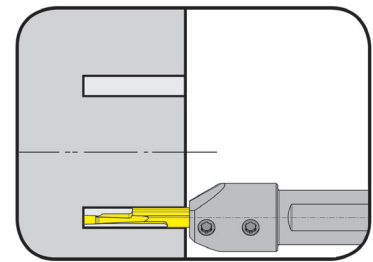

A

für Schneidplatte
for insert

Typ A109
Type

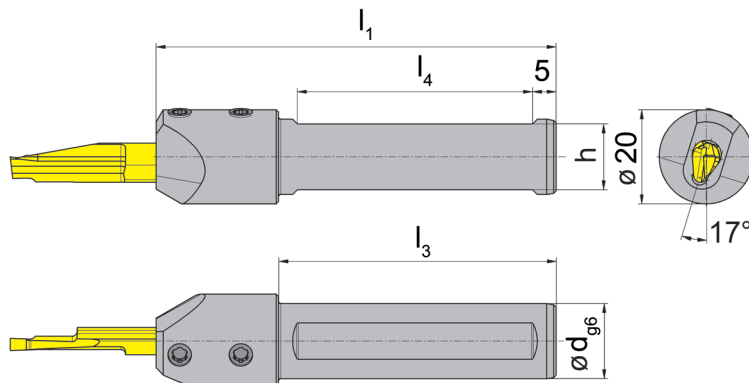

nur für Schneidplatten mit verlängertem Spannschaft
only usable for inserts with extended clamping length

R = rechts wie gezeichnet
R = right hand version shown

L = links spiegelbildlich
L = left hand version

Bestellnummer Part number	d	l ₁	l ₃	h	l ₄
R/LB109.0016.14.2	16	85	59	14	50

Ausführung R oder L angeben
State R or L version

Abmessungen in mm
Dimensions in mm

Weitere Abmessungen auf Anfrage
Further sizes upon request

Das Anzugsdrehmoment der Schrauben finden Sie in den Technischen Hinweisen.
For torque specification of the screw, please see Technical Instructions.

Ersatzteile

Spare parts

Klemmhalter Toolholder	Spannschraube Clamping Screw	TORX PLUS®-Schlüssel TORX PLUS® Wrench
R/LB109.0016.14.2	6.075T15P	T15PQ

Axialeinstechen

Face Grooving



Schneidplatte

Insert

A109

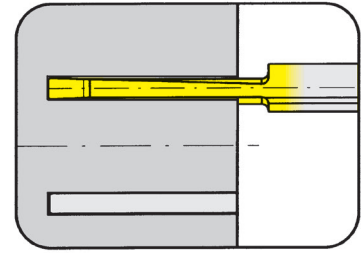

Nutaußen-Ø ab	from outer groove Ø	15 mm
Stechtiefe	Depth of groove	20 mm
Stechbreite	Width of groove	2-3 mm

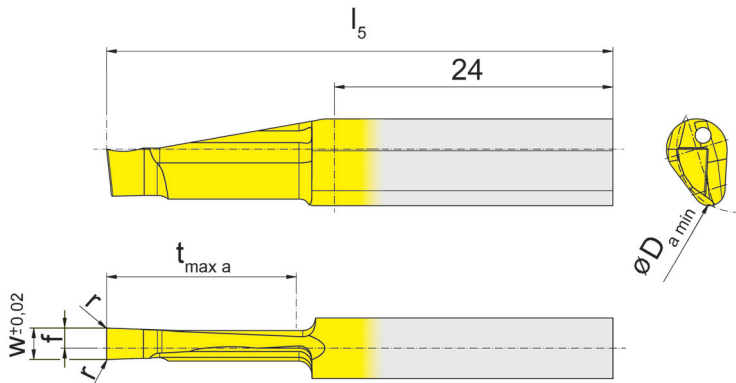

für Klemmhalter
for Toolholder

Typ B109
Type

L = links wie gezeichnet
L = left hand version shown

R = rechts spiegelbildlich
R = right hand version

Bestellnummer Part number	w	r	f	l ₅	t _{max a}	D _{a min}	Ti25
R/LA109.1520.3.2	2,0	0,1	1,0	48	20	15	▲/Δ
R/LA109.1525.3.2	2,5	0,1	1,2	48	20	15	▲/Δ
R/LA109.1530.3.2	3,0	0,1	1,5	48	20	15	▲/▲

▲ ab Lager / on stock Δ 4 Wochen / 4 weeks x auf Anfrage / upon request

● empfohlen / recommended

o bedingt einsetzbar / alternative recommendation

- nicht geeignet / not suitable

■ unbeschichtete HM-Sorten / uncoated grades

■ beschichtete HM-Sorten / coated grades

■ bestückt/Cermet / brazed/Cermet

Abmessungen in mm

Dimensions in mm

Weitere Abmessungen auf Anfrage

Further sizes upon request

HM-Sorten

Carbide grades

Ausführung R oder L angeben

State R or L version

Hinweis:

Schneidplatte RA109 in Klemmhalter RB109 und Schneidplatte LA109 in Klemmhalter LB109 verwenden

Note:

Use insert RA109 in toolholder RB109

Use insert LA109 in toolholder LB109

Axialstechen ins Volle bei voller Stechtiefe nur bei D_{amin} 15 - 40 mm möglich!

Face grooving with full width of the full depth only possible between D_{amin} 15 - 40 mm!

P	•
M	•
K	•
N	•
S	•
H	-

B

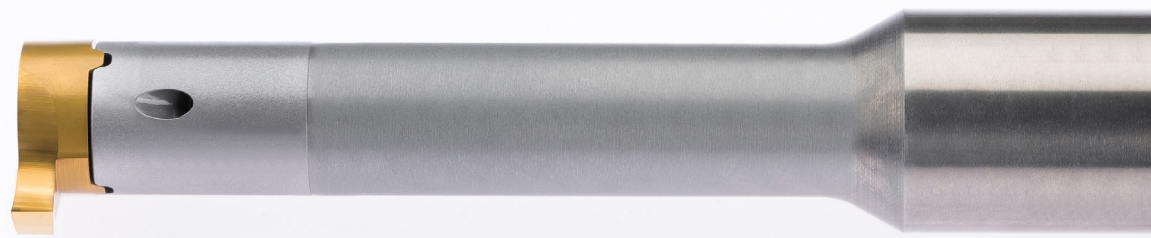

System/System

Seite/Page

106

B2

107

B10

108

B20

Klemmhalter
Toolholder
B106

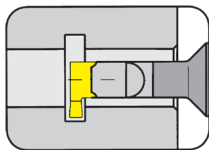

Seite/Page
B5

Schneidplatte
Insert
106

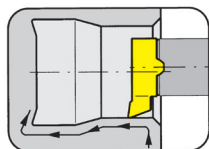

Seite/Page
B6

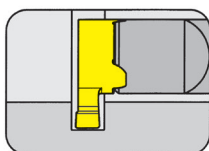

Seite/Page
B7

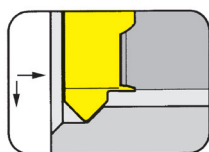

Seite/Page
B8

B

106

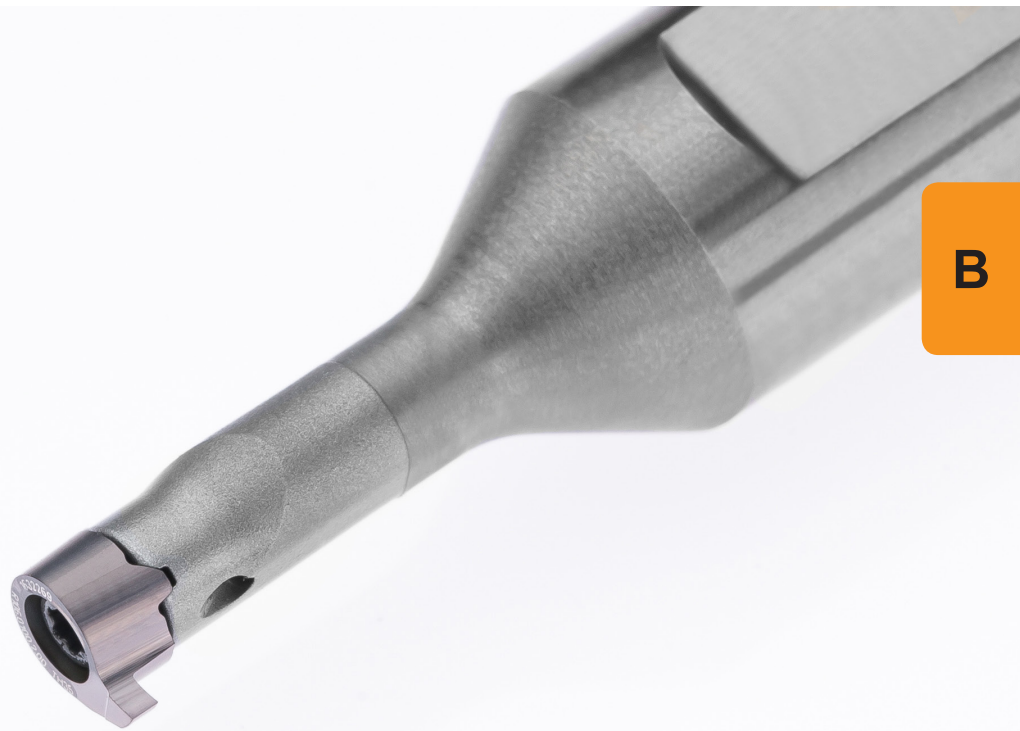

B

**Klemmhalter mit
Schneidplatten**

Stechbreite 0,7 - 1,5 mm

**Toolholder with
Inserts**

Width of groove 0,7 - 1,5 mm

HCG - HORN Catalogue Guide

Innenbearbeitung / Internal Grooving

B

Bohrungs-Ø Bore Ø	Artikelgruppen / Product line		
	106	107	108
≥ 6,0	•		
≥ 6,8	•		
≥ 7,0		•	
≥ 7,8		•	•
≥ 8,0		•	•
≥ 9,0		•	•
≥ 10,0			
≥ 10,5			
≥ 11,0			
≥ 11,5			
≥ 13,8			
≥ 14,0			
≥ 16,0			
≥ 16,5			
≥ 18,0			
Stechtiefe Depth of groove	0,8	2,0	1,0
Stechbreite Width of groove	0,7-1,5	1,0-2,0	0,7-2,0
Bearbeitung / Machining			
Einstechen / Grooving	•	•	•
Ausdrehen / Boring	•	•	•
Gewindedrehen / Threading		•	•
Fasen / Chamfering	•	•	•
Axialeinstechen / Face Grooving			

Abmessung in mm
Dimensions in mm

Das komplette Programm für die Innenbearbeitung finden Sie in unserem Katalog „SUPERMINI UND MINI“.

You will find the complete programme for internal machining in our catalogue „SUPERMINI AND MINI“.

Einstecken und Ausdrehen

Grooving and Boring



Klemmhalter

Toolholder

B106

mit innerer Kühlmittelzufuhr
with through coolant supply

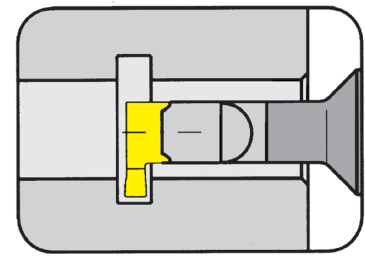

Bohrungs-Ø ab	Bore Ø from	6 mm
Stechtiefe bis	Depth of groove up to	0,8 mm
Stechbreite bis	Width of groove up to	1,5 mm

Schaftmaterial: Hartmetall (schwingungsarm)
Material of shank: Carbide - Giving a good vibration resistance

für Schneidplatte
for Insert

Typ 106
Type

B

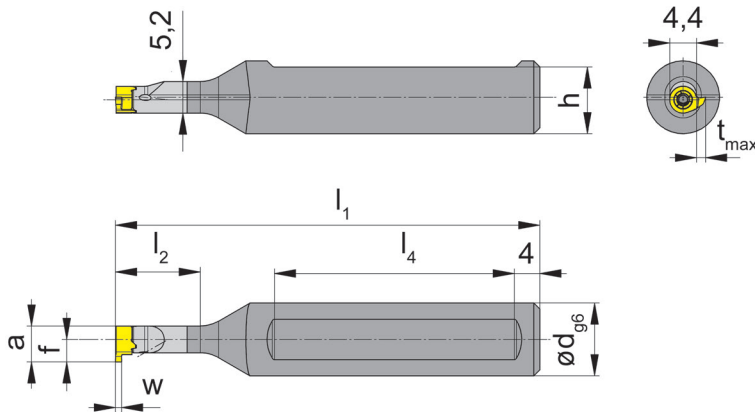

R = rechts wie gezeichnet
R = right hand version shown

L = links spiegelbildlich
L = left hand version

Bestellnummer Part number	d	l ₁	l ₂	h	l ₄
R/LB106.0012.01	12	70	14	11	40
R/LB106.0012.02	12	80	20	11	40
R/LB106.0012.03	12	90	26	11	45

Weitere Abmessungen auf Anfrage
Further sizes upon request

w, a, t_{max} und f siehe Schneidplatten
w, a, t_{max} and f see inserts

Abmessungen in mm
Dimensions in mm

Bestellhinweis:

Klemmhalter mit beschädigter Schneidplattenaufnahme können durch unseren Reparaturservice instand gesetzt werden.

Ordering note:

Toolholders with damaged seating can be repaired by HORN.

Das Anzugsdrehmoment der Schrauben finden Sie in den Technischen Hinweisen.

For torque specification of the screw, please see Technical Instructions.

Ersatzteile

Spare Parts

Klemmhalter Toolholder	Spannschraube Clamping Screw	TORX PLUS®-Schlüssel TORX PLUS® Wrench
R/LB106...	1.8.4T6EP	T6PL

Schneidplatte

Insert

106

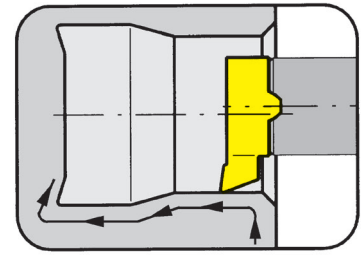

Bohrungs-Ø ab	Bore Ø from	6 mm
---------------	-------------	------

B

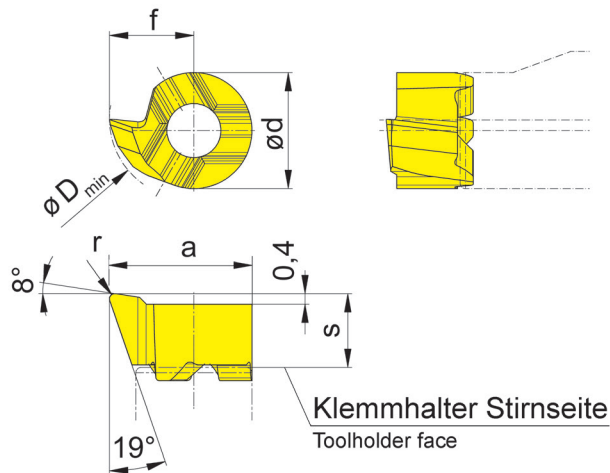

für Klemmhalter
for Toolholder

Typ B106
Type

R = rechts wie gezeichnet
R = right hand version shown

L = links spiegelbildlich
L = left hand version

Bestellnummer Part number	s	f	a	r	d	D _{min}	EG55	TH35
R/L106.1831.1.005	2,8	3,2	5,4	0,05	4,4	6	▲/Δ	▲/Δ
R/L106.1831.1.02	2,8	3,2	5,4	0,20	4,4	6	▲/Δ	▲/▲
R/L106.1831.1.04	2,8	3,2	5,4	0,40	4,4	6	▲/Δ	▲/▲
							P	•
							M	○
							K	○
							N	-
							S	-
							H	-

▲ ab Lager / on stock Δ 4 Wochen / 4 weeks x auf Anfrage / upon request

● empfohlen / recommended

○ bedingt einsetzbar / alternative recommendation

- nicht geeignet / not suitable

■ unbeschichtete HM-Sorten / uncoated grades

■ beschichtete HM-Sorten / coated grades

■ bestückt/Cermet / brazed/Cermet

Abmessungen in mm

Dimensions in mm

Ausführung R oder L angeben

State R or L version

HM-Sorten

Carbide grades

Die besondere Schneidengeometrie erlaubt das Ausdrehen von Bohrungen $\geq \varnothing 6,8$ mm und das Kopieren von Freistichen gemäß DIN 509 Form E und F.

The modified geometry allows boring of bores $\geq \varnothing 6,8$ mm and profiling of reliefs as per DIN 509 form E and F.

Weitere Abmessungen auf Anfrage

Further sizes upon request

Rechte Schneidplatte in rechten, linke Schneidplatte in linken Klemmhaltern verwenden.

Use right hand inserts in right hand toolholders and left hand inserts in left hand toolholders.

Einstecken (innen)

Grooving (internal)



Schneidplatte

Insert

106

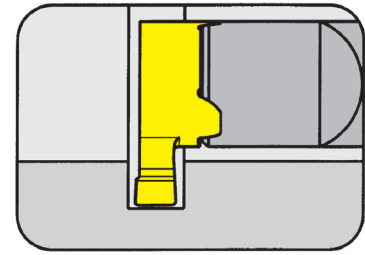

Bohrungs-Ø ab	Bore Ø from	6,5 mm
Stechtiefe bis	Depth of groove up to	0,8 mm
Stechbreite bis	Width of groove up to	1,5 mm

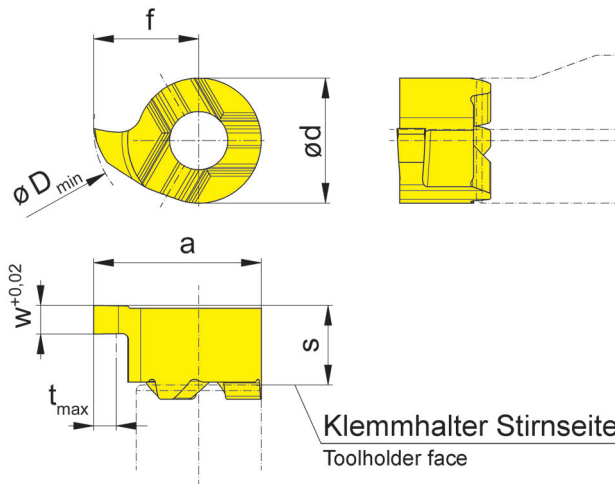

für Klemmhalter
for Toolholder

Typ B106
Type

R = rechts wie gezeichnet
R = right hand version shown

L = links spiegelbildlich
L = left hand version

Bestellnummer Part number	w	s	f	a	d	t _{max}	D _{min}	EG55	TH35
R/L106.0070.2.00	0,74	2,8	3,7	5,9	4,4	0,8	6,5	▲/Δ	▲/Δ
R/L106.0100.2.00	1,00	2,8	3,7	5,9	4,4	0,8	6,5	Δ/Δ	▲/Δ
R/L106.0150.2.00	1,50	2,8	3,7	5,9	4,4	0,8	6,5	Δ/Δ	▲/Δ

▲ ab Lager / on stock Δ 4 Wochen / 4 weeks x auf Anfrage / upon request

● empfohlen / recommended

o bedingt einsetzbar / alternative recommendation

- nicht geeignet / not suitable

■ unbeschichtete HM-Sorten / uncoated grades

■ beschichtete HM-Sorten / coated grades

■ bestückt/Cermet / brazed/Cermet

Abmessungen in mm

Dimensions in mm

Ausführung R oder L angeben

State R or L version

Weitere Abmessungen auf Anfrage

Further sizes upon request

Rechte Schneidplatte in rechten, linke Schneidplatte in linken Klemmhaltern verwenden.

Use right hand inserts in right hand toolholders and left hand inserts in left hand toolholders.

P	●	●
M	○	●
K	○	●
N	-	●
S	-	●
H	-	-

HM-Sorten
Carbide grades



Fasen und Rückwärtsdrehen (innen)

Chamfering and Backboring (internal)



Schneidplatte

106

Insert

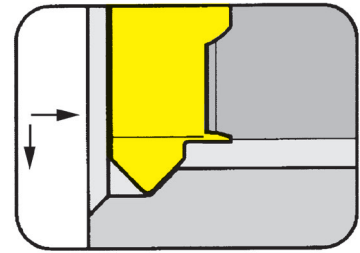

Bohrungs-Ø ab Schnitttiefe bis	Bore Ø from Depth of cut up to	6 mm 0,6 mm
-----------------------------------	-----------------------------------	----------------

B

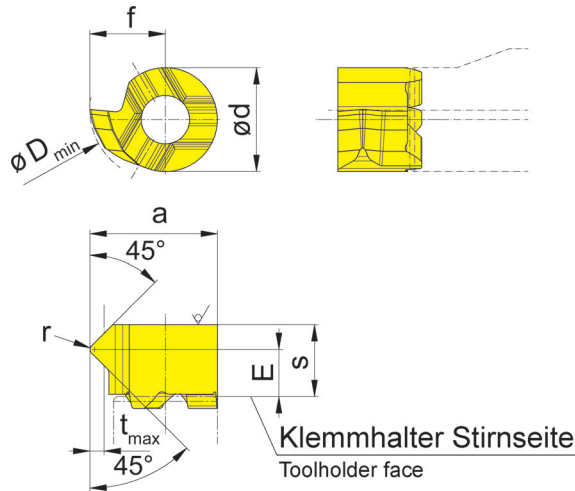

für Klemmhalter
for Toolholder

Typ B106
Type

R = rechts wie gezeichnet
R = right hand version shown

L = links spiegelbildlich
L = left hand version

Bestellnummer Part number	E	s	f	a	r	d	t _{max}	D _{min}	EG55	TH35
R/L106.4545.1.02	2	3,05	3,2	5,4	0,2	4,4	0,6	6	▲/Δ	▲/Δ

▲ ab Lager / on stock Δ 4 Wochen / 4 weeks x auf Anfrage / upon request

● empfohlen / recommended

o bedingt einsetzbar / alternative recommendation

- nicht geeignet / not suitable

■ unbeschichtete HM-Sorten / uncoated grades

■ beschichtete HM-Sorten / coated grades

■ bestückt/Cermet / brazed/Cermet

Abmessungen in mm

Dimensions in mm

Ausführung R oder L angeben

State R or L version

Weitere Abmessungen auf Anfrage

Further sizes upon request

Rechte Schneidplatte in rechten, linke Schneidplatte in linken Klemmhaltern verwenden.

Use right hand inserts in right hand toolholders and left hand inserts in left hand toolholders.

P	●	●
M	o	●
K	o	●
N	-	●
S	-	●
H	-	-

HM-Sorten
Carbide grades



Klemmhalter
Toolholder
B107

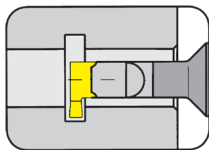

Seite/Page
B13

Schneidplatte
Insert
107

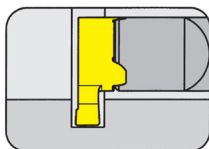

Seite/Page
B14-B15

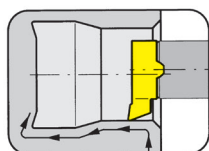

Seite/Page
B16

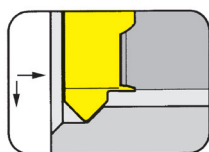

Seite/Page
B17

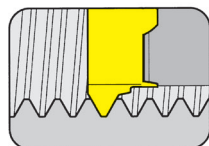

Seite/Page
B18

B

107

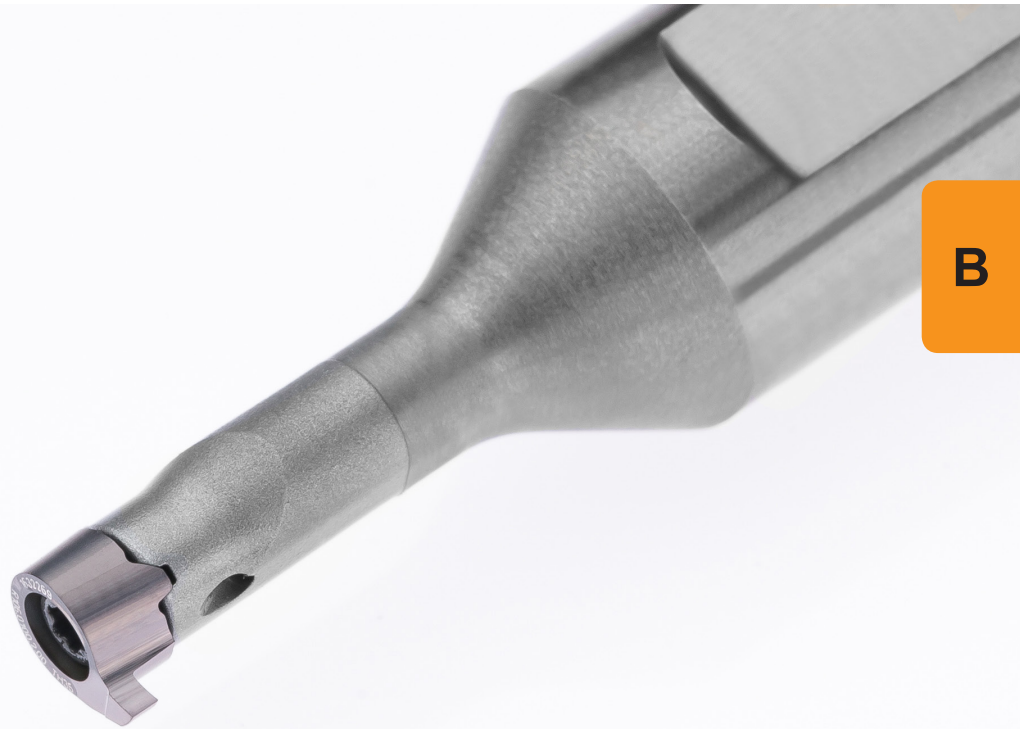

**Klemmhalter mit
Schneidplatten**

Stechbreite 1 - 2 mm

**Toolholder with
Inserts**

Width of groove 1 - 2 mm

HCG - HORN Catalogue Guide

Innenbearbeitung / Internal Grooving

B

Bohrungs-Ø Bore Ø	Artikelgruppen / Product line		
	106	107	108
≥ 6,0	•		
≥ 6,8	•		
≥ 7,0		•	
≥ 7,8		•	•
≥ 8,0		•	•
≥ 9,0		•	•
≥ 10,0			
≥ 10,5			
≥ 11,0			
≥ 11,5			
≥ 13,8			
≥ 14,0			
≥ 16,0			
≥ 16,5			
≥ 18,0			
Stechtiefe Depth of groove	0,8	2,0	1,0
Stechbreite Width of groove	0,7-1,5	1,0-2,0	0,7-2,0
Bearbeitung / Machining			
Einstechen / Grooving	•	•	•
Ausdrehen / Boring	•	•	•
Gewindedrehen / Threading			•
Fasen / Chamfering	•	•	•
Axialeinstechen / Face Grooving			

Abmessung in mm
Dimensions in mm

Das komplette Programm für die Innenbearbeitung finden Sie in unserem Katalog „SUPERMINI UND MINI“.

You will find the complete programme for internal machining in our catalogue „SUPERMINI AND MINI“.

Einstechen und Ausdrehen

Grooving and Boring



Klemmhalter

Toolholder

B107

mit innerer Kühlmittelzufuhr
with through coolant supply

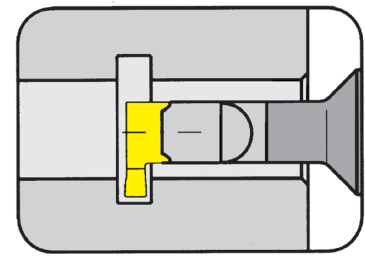

Bohrungs-Ø ab	Bore Ø from	7 mm
Stechtiefe bis	Depth of groove up to	2 mm
Stechbreite bis	Width of groove up to	2 mm

Schaftmaterial: Hartmetall (schwingungsarm)
Material of shank: Carbide - Giving a good vibration resistance

für Schneidplatte
for Insert

Typ 107
Type

B

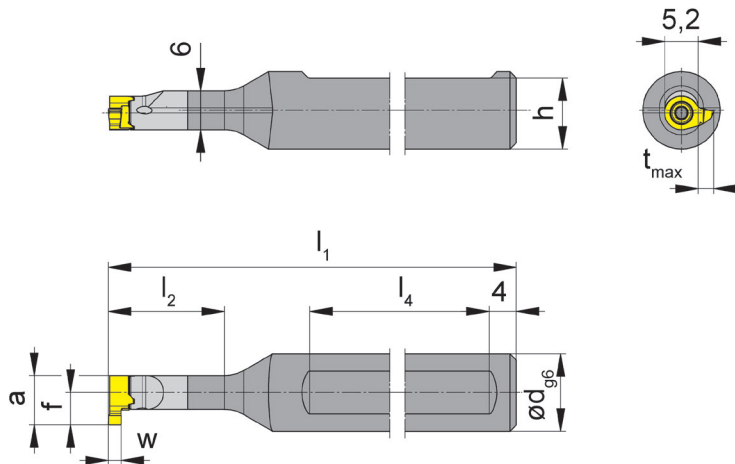

R = rechts wie gezeichnet
R = right hand version shown

L = links spiegelbildlich
L = left hand version

Bestellnummer Part number	d	l ₁	l ₂	h	l ₄
R/LB107.0012.01	12	80	18	11	45
R/LB107.0012.02	12	90	26	11	45
R/LB107.0012.03	12	100	36	11	45

Ausführung R oder L angeben
State R or L version

w, a, t_{max} und f siehe Schneidplatten
w, a, t_{max} and f see inserts

Abmessungen in mm
Dimensions in mm

Weitere Abmessungen auf Anfrage
Further sizes upon request

Bestellhinweis:

Klemmhalter mit beschädigter Schneidplattenaufnahme können durch unseren Reparaturservice instand gesetzt werden.

Ordering note:

Toolholders with damaged seating can be repaired by HORN.

Das Anzugsdrehmoment der Schrauben finden Sie in den Technischen Hinweisen.

For torque specification of the screw, please see Technical Instructions.

Ersatzteile

Spare Parts

Klemmhalter Toolholder	Spannschraube Clamping Screw	TORX PLUS®-Schlüssel TORX PLUS® Wrench
R/LB107...	2.2.5T7EP	T7PL

Einstecken (innen)

Grooving (internal)



Schneidplatte

Insert

107

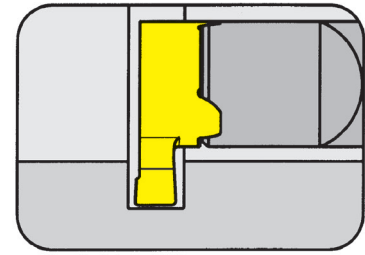

Bohrungs-Ø ab	Bore Ø from	7 mm
Stechtiefe bis	Depth of groove up to	1 mm
Stechbreite bis	Width of groove up to	1,5 mm

B

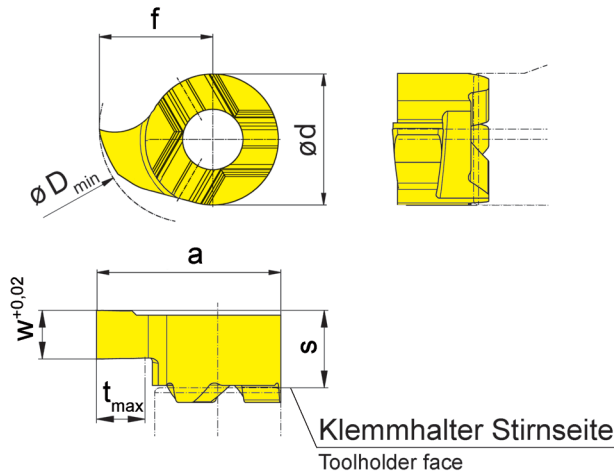

für Klemmhalter
for Toolholder

Typ
Type B107

R = rechts wie gezeichnet
R = right hand version shown

L = links spiegelbildlich
L = left hand version

Bestellnummer Part number	w	s	f	a	d	t _{max}	D _{min}	EG55	TH35
R/L107.0100.1.00	1,0	3,3	4	6,6	5,2	1	7	▲/Δ	▲/Δ
R/L107.0150.1.00	1,5	3,3	4	6,6	5,2	1	7	▲/Δ	▲/▲

- ▲ ab Lager / on stock Δ 4 Wochen / 4 weeks x auf Anfrage / upon request
- empfohlen / recommended
- o bedingt einsetzbar / alternative recommendation
- nicht geeignet / not suitable
- unbeschichtete HM-Sorten / uncoated grades
- beschichtete HM-Sorten / coated grades
- bestückt/Cermet / brazed/Cermet

Abmessungen in mm
Dimensions in mm

Ausführung R oder L angeben
State R or L version

Weitere Abmessungen auf Anfrage
Further sizes upon request

P	●	●
M	o	●
K	o	●
N	-	●
S	-	●
H	-	-

HM-Sorten
Carbide grades

Einstecken (innen)

Grooving (internal)



Schneidplatte

Insert

107

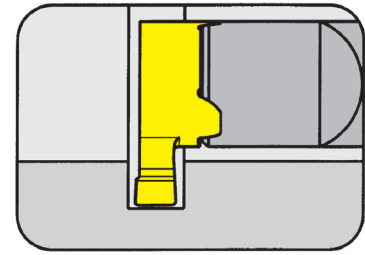

Bohrungs-Ø ab	Bore Ø from	8 mm
Stechtiefe bis	Depth of groove up to	2 mm
Stechbreite bis	Width of groove up to	2 mm

für Klemmhalter
for Toolholder

Typ
Type B107

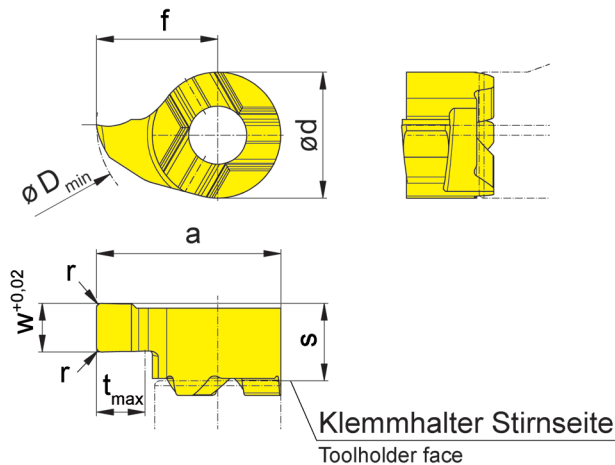

R = rechts wie gezeichnet
R = right hand version shown

L = links spiegelbildlich
L = left hand version

Bestellnummer Part number	w	s	f	a	r	d	t _{max}	D _{min}	EG55	TH35
R/L107.0100.2.00	1,0	3,3	5	7,6	-	5,2	2	8	▲/Δ	▲/Δ
R/L107.0150.2.01	1,5	3,3	5	7,6	0,1	5,2	2	8	▲/Δ	▲/▲
R/L107.0200.2.02	2,0	3,3	5	7,6	0,2	5,2	2	8	▲/Δ	▲/▲

▲ ab Lager / on stock Δ 4 Wochen / 4 weeks x auf Anfrage / upon request

● empfohlen / recommended

o bedingt einsetzbar / alternative recommendation

- nicht geeignet / not suitable

■ unbeschichtete HM-Sorten / uncoated grades

■ beschichtete HM-Sorten / coated grades

■ bestückt/Cermet / brazed/Cermet

Abmessungen in mm

Dimensions in mm

Ausführung R oder L angeben

State R or L version

Weitere Abmessungen auf Anfrage

Further sizes upon request

P	●	●
M	○	●
K	○	●
N	-	●
S	-	●
H	-	-

HM-Sorten
Carbide grades

Schneidplatte

Insert

107

Bohrungs-Ø ab	Bore Ø from	6,8 mm
---------------	-------------	--------

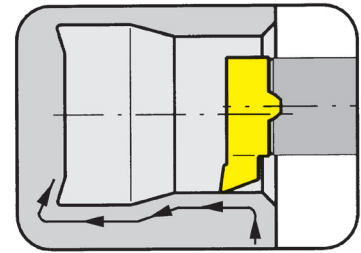

für Klemmhalter
for Toolholder

Typ
Type B107

B

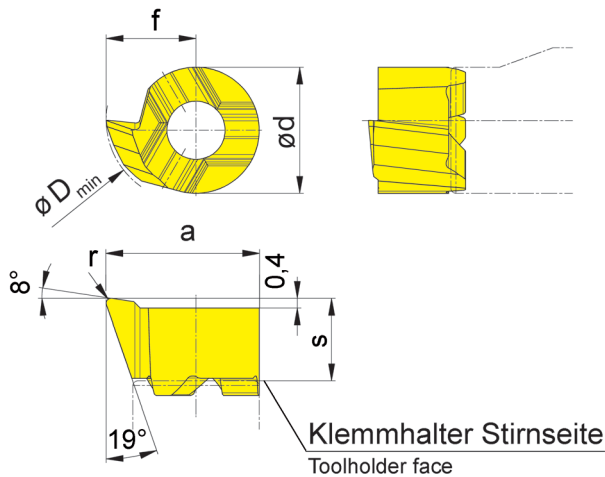

R = rechts wie gezeichnet
R = right hand version shown

L = links spiegelbildlich
L = left hand version

Bestellnummer Part number	s	f	a	r	d	D _{min}	EG55	TH35
R/L107.1837.02	3,3	3,7	6,3	0,2	5,2	6,8	▲/▲	▲/▲
R/L107.1837.04	3,3	3,7	6,3	0,4	5,2	6,8	▲/▲	▲/▲

- ▲ ab Lager / on stock Δ 4 Wochen / 4 weeks x auf Anfrage / upon request
- empfohlen / recommended
- o bedingt einsetzbar / alternative recommendation
- nicht geeignet / not suitable
- unbeschichtete HM-Sorten / uncoated grades
- beschichtete HM-Sorten / coated grades
- bestückt/Cermet / brazed/Cermet

P	●	●
M	○	●
K	○	●
N	-	●
S	-	●
H	-	-

HM-Sorten
Carbide grades

Abmessungen in mm
Dimensions in mm

Ausführung R oder L angeben
State R or L version

Die besondere Schneidengeometrie erlaubt das Ausdrehen von Bohrungen $\geq \varnothing 6,8$ mm und das Kopieren von Freistichen gemäß DIN 509 Form E und F.

The modified geometry allows boring of bores $\geq \varnothing 6,8$ mm and profiling of reliefs as per DIN 509 form E and F.

Weitere Abmessungen auf Anfrage
Further sizes upon request

Fasen und Rückwärtsdrehen (innen)

Chamfering and Backboring (internal)



Schneidplatte

107

Insert

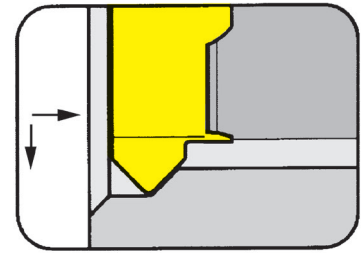

Bohrungs-Ø ab Schnittiefe bis	Bore Ø from Depth of cut up to	6,8 mm 0,8 mm
----------------------------------	-----------------------------------	------------------

für Klemmhalter
for Toolholder

Typ
Type B107

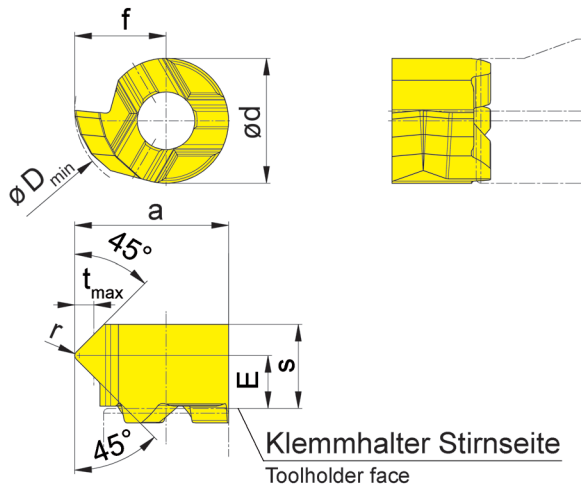

R = rechts wie gezeichnet
R = right hand version shown

L = links spiegelbildlich
L = left hand version

Bestellnummer Part number	E	s	f	a	r	d	t _{max}	D _{min}	EG55	TH35
R/L107.4545.1.02	2,2	3,5	3,8	6,4	0,2	5,2	0,8	6,8	▲/Δ	▲/Δ

▲ ab Lager / on stock Δ 4 Wochen / 4 weeks x auf Anfrage / upon request

● empfohlen / recommended

o bedingt einsetzbar / alternative recommendation

- nicht geeignet / not suitable

■ unbeschichtete HM-Sorten / uncoated grades

■ beschichtete HM-Sorten / coated grades

■ bestückt/Cermet / brazed/Cermet

Abmessungen in mm

Dimensions in mm

Ausführung R oder L angeben

State R or L version

Weitere Abmessungen auf Anfrage

Further sizes upon request

P	●	●
M	o	●
K	o	●
N	-	●
S	-	●
H	-	-

HM-Sorten
Carbide grades

Gewindedrehen (innen) Teilprofil

Threading (internal) Partial profile



Schneidplatte

Insert

107

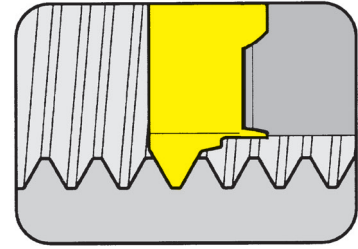

Bohrungs-Ø ab Steigung	Bore Ø from Pitch	7 mm 0,5-1,75 mm
------------------------	-------------------	---------------------

B

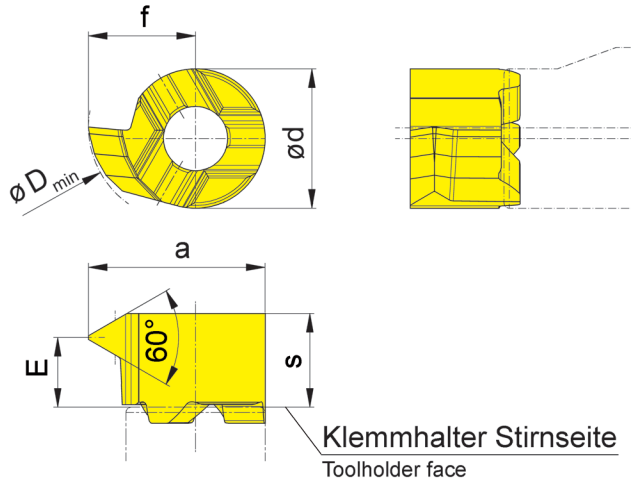

für Klemmhalter
for Toolholder

Typ
Type B107

R = rechts wie gezeichnet
R = right hand version shown

L = links spiegelbildlich
L = left hand version

Metrisches ISO-Gewinde
Metric ISO-thread

Bestellnummer Part number	P	P _{max}	E	f	a	d	s	D _{min}	EG55	TH35
R/L107.0205.1.01	0,5	0,75	3,0	4	6,6	5,2	3,5	7	Δ/Δ	▲/Δ
R/L107.0510.1.01	1,0	1,25	2,8	4	6,6	5,2	3,5	7	▲/Δ	▲/▲
R/L107.0815.1.01	1,5	1,75	2,6	4	6,6	5,2	3,5	7	▲/Δ	▲/Δ

▲ ab Lager / on stock Δ 4 Wochen / 4 weeks x auf Anfrage / upon request

● empfohlen / recommended

o bedingt einsetzbar / alternative recommendation

- nicht geeignet / not suitable

■ unbeschichtete HM-Sorten / uncoated grades

■ beschichtete HM-Sorten / coated grades

■ bestückt/Cermet / brazed/Cermet

Abmessungen in mm

Dimensions in mm

Ausführung R oder L angeben

State R or L version

Weitere Abmessungen auf Anfrage

Further sizes upon request

	EG55	TH35
P	●	●
M	○	●
K	○	●
N	-	●
S	-	●
H	-	-

HM-Sorten
Carbide grades



Klemmhalter
Toolholder
B108

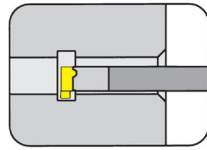

Seite/Page
B23

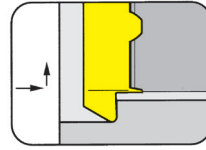

Seite/Page
B33

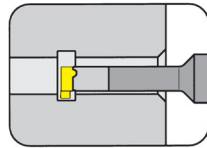

Seite/Page
B24

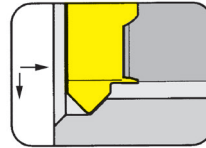

Seite/Page
B35

Schneidplatte
Insert
108/S108

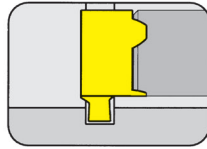

Seite/Page
B25-B26, B28

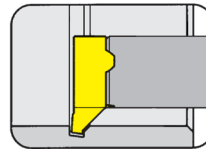

Seite/Page
B36

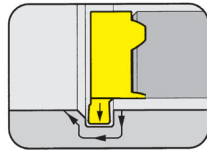

Seite/Page
B27

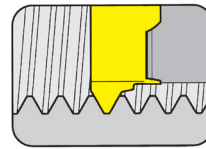

Seite/Page
B37-B38, B41

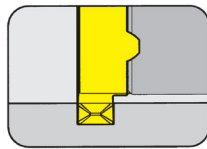

Seite/Page
B29

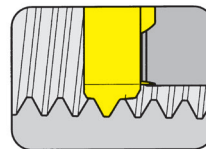

Seite/Page
B39-B40, B42

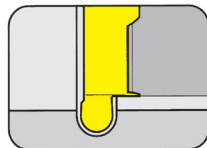

Seite/Page
B30

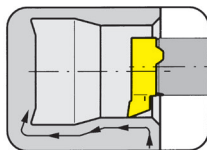

Seite/Page
B31-B32, B34

B

108



**Klemmhalter mit
Schneidplatten**

Stechbreite 0,7 - 2,0 mm

**Toolholder with
Inserts**

Width of groove 0,7 - 2,0 mm

HCG - HORN Catalogue Guide

Innenbearbeitung / Internal Grooving

B

Bohrungs-Ø Bore Ø	Artikelgruppen / Product line		
	106	107	108
≥ 6,0	•		
≥ 6,8	•		
≥ 7,0		•	
≥ 7,8		•	•
≥ 8,0		•	•
≥ 9,0		•	•
≥ 10,0			
≥ 10,5			
≥ 11,0			
≥ 11,5			
≥ 13,8			
≥ 14,0			
≥ 16,0			
≥ 16,5			
≥ 18,0			

Stechtiefe Depth of groove	0,8	2,0	1,0

Stechbreite Width of groove	0,7-1,5	1,0-2,0	0,7-2,0

Bearbeitung / Machining			
Einstechen / Grooving	•	•	•
Ausdrehen / Boring	•	•	•
Gewindedrehen / Threading			•
Fasen / Chamfering	•	•	•
Axialeinstechen / Face Grooving			

Abmessung in mm
Dimensions in mm

Das komplette Programm für die Innenbearbeitung finden Sie in unserem Katalog „SUPERMINI UND MINI“.

You will find the complete programme for internal machining in our catalogue „SUPERMINI AND MINI“.

Einstechen und Ausdrehen

Grooving and Boring



Klemmhalter

Toolholder

B108

mit innerer Kühlmittelzufuhr
with through coolant supply

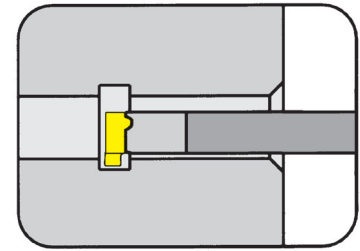

Bohrungs-Ø ab	Bore Ø from	8 mm
Stechtiefe bis	Depth of groove up to	1 mm
Stechbreite bis	Width of groove up to	2 mm

Schaftmaterial: Hartmetall (schwingungsarm)
Material of shank: Carbide - Giving a good vibration resistance

für Schneidplatte
for Insert

Typ 108
Type S108

B



Abbildung = rechtsschneidend
Picture = right hand cutting version

Bestellnummer Part number	d	l ₁	l ₂	h	l ₄	d ₁
B108.0006.01A	6	65	-	-	-	-
B108.0008.00	8	60	12,5	7	35	6
B108.0008.01	8	70	21,0	7	40	6
B108.0012.00	12	70	12,5	11	40	6
B108.0012.01	12	80	21,0	11	45	6
B108.0012.02	12	90	30,0	11	45	6
B108.0012.03	12	100	42,0	11	45	6

Weitere Abmessungen auf Anfrage
Further sizes upon request

w, a, t_{max} und f siehe Schneidplatten
w, a, t_{max} and f see inserts

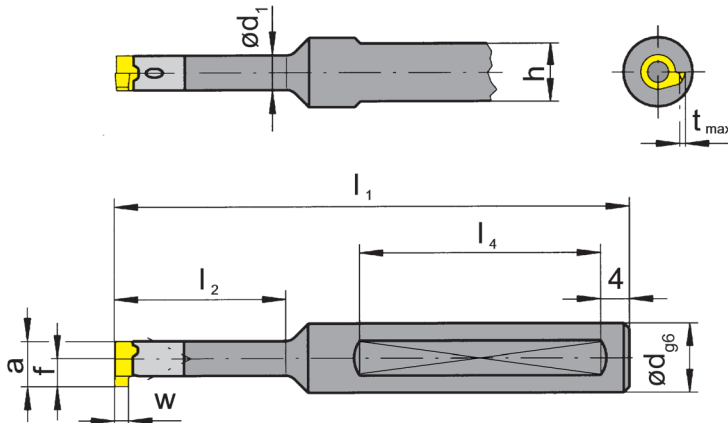
Abmessungen in mm
Dimensions in mm

Bestellhinweis:

Klemmhalter sind jeweils für rechte und linke Schneidplatten verwendbar.
Klemmhalter mit beschädigter Schneidplattenaufnahme können durch unseren Reparaturservice instand gesetzt werden.

Ordering note:

Toolholders can be used with right and left hand inserts. Toolholders with damaged seating can be repaired by HORN.

Das Anzugsdrehmoment der Schrauben finden Sie in den Technischen Hinweisen.
For torque specification of the screw, please see Technical Instructions.

Ersatzteile

Spare Parts

Klemmhalter Toolholder	Spannschraube Clamping Screw	TORX PLUS®-Schlüssel TORX PLUS® Wrench
B108...	2.6.5T8EP	T8PL

Einstechen und Ausdrehen

Grooving and Boring



Klemmhalter

Toolholder

B108

mit innerer Kühlmittelzufuhr
with through coolant supply

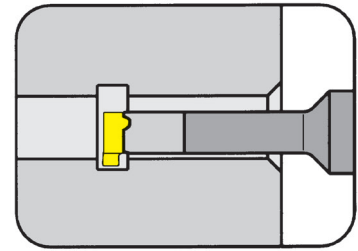

Bohrungs-Ø ab	Bore Ø from	8 mm
Stechtiefe bis	Depth of groove up to	1 mm
Stechbreite bis	Width of groove up to	2 mm

Schaftmaterial: Hartmetall (schwingungsarm)
Material of shank: Carbide - Giving a good vibration resistance

für Schneidplatte
for Insert

Typ 108
Type S108



Abbildung = rechtsschneidend
Picture = right hand cutting version

zum lageorientierten
Schrumpfen
for shrinkage location

Bestellnummer Part number	d	l_1	l_2	d_1
B108.0012.00S	12	48,7	12,5	6
B108.0012.01S	12	56,7	21,0	6
B108.0012.02S	12	65,7	30,0	6
B108.0012.03S	12	77,7	42,0	6

Weitere Abmessungen auf Anfrage
Further sizes upon request

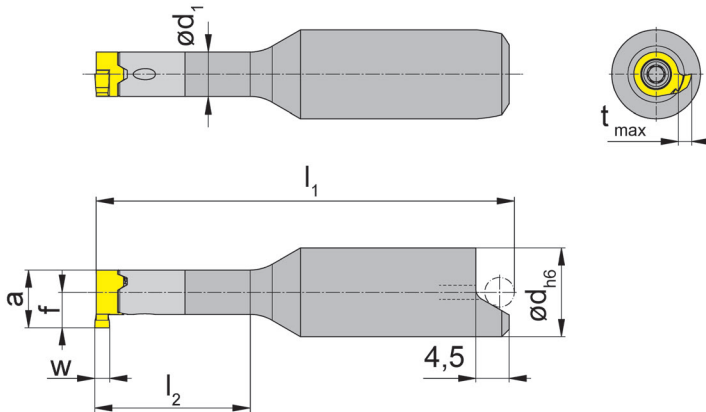
w, a, t_{max} und f siehe Schneidplatten
w, a, t_{max} and f see inserts

Abmessungen in mm
Dimensions in mm

Bestellhinweis:

Klemmhalter sind jeweils für rechte und linke Schneidplatten verwendbar.
Klemmhalter mit beschädigter Schneidplattenaufnahme können durch unseren Reparaturservice instand gesetzt werden.

Ordering note:

Toolholders can be used with right and left hand inserts. Toolholders with damaged seating can be repaired by HORN.

Das Anzugsdrehmoment der Schrauben finden Sie in den Technischen Hinweisen.
For torque specification of the screw, please see Technical Instructions.

Ersatzteile

Spare Parts

Klemmhalter Toolholder	Spannschraube Clamping Screw	TORX PLUS®-Schlüssel TORX PLUS® Wrench
B108...	2.6.5T8EP	T8PL

Einstecken (innen)

Grooving (internal)



Schneidplatte

Insert

108

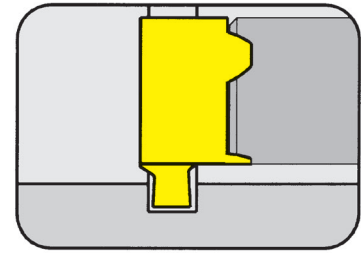

Bohrungs-Ø ab Nutnennbreite Nw	Bore Ø from Width of circlip Nw	8 mm 0,7-0,9 mm
-----------------------------------	------------------------------------	--------------------

Abmessungen für Seegerringnuten DIN 471/472
Widths for circlip grooves DIN 471/472

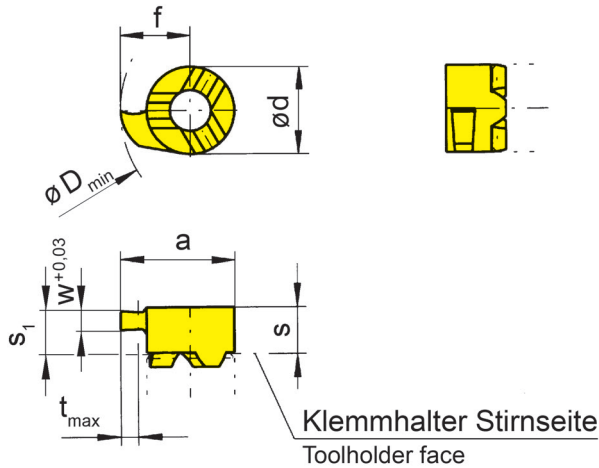

Klemmhalter Stirnseite
Toolholder face

für Klemmhalter
for Toolholder

Typ B108
Type

R = rechts wie gezeichnet
R = right hand version shown

L = links spiegelbildlich
L = left hand version

Zapfenausführung
not face cutting,
limited depth of cut

Bestellnummer Part number	Nw	w	s	s ₁	f	a	d	t _{max}	D _{min}	EG55	TH35	TN35
R/L108.0070.00	0,7	0,74	3,6	3,2	4,8	7,8	6	1	8	▲/▲	▲/▲	▲/▲
R/L108.0080.00	0,8	0,84	3,6	3,2	4,8	7,8	6	1	8	▲/▲	▲/▲	▲/▲
R/L108.0090.00	0,9	0,94	3,6	3,2	4,8	7,8	6	1	8	▲/▲	▲/▲	▲/▲
										P	•	•
										M	○	•
										K	○	•
										N	-	•
										S	-	•
										H	-	-

▲ ab Lager / on stock Δ 4 Wochen / 4 weeks x auf Anfrage / upon request

● empfohlen / recommended

○ bedingt einsetzbar / alternative recommendation

- nicht geeignet / not suitable

■ unbeschichtete HM-Sorten / uncoated grades

■ beschichtete HM-Sorten / coated grades

■ bestückt/Cermet / brazed/Cermet

Abmessungen in mm

Dimensions in mm

Ausführung R oder L angeben

State R or L version

Weitere Abmessungen auf Anfrage

Further sizes upon request

HM-Sorten
Carbide grades



Einstecken (innen)

Grooving (internal)



Schneidplatte

Insert

108

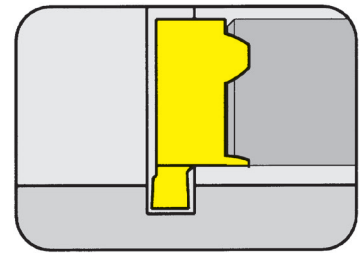

Bohrungs-Ø ab Nutnennbreite Nw	Bore Ø from Width of circlip Nw	8 mm 1,1-1,6 mm
-----------------------------------	------------------------------------	--------------------

Abmessungen für Seegerringnuten DIN 471/472
Widths for circlip grooves DIN 471/472

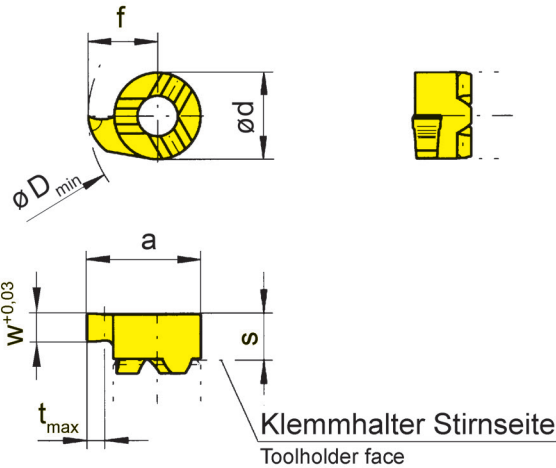

für Klemmhalter
for Toolholder

Typ B108
Type

B

R = rechts wie gezeichnet
R = right hand version shown

L = links spiegelbildlich
L = left hand version

Bestellnummer Part number	Nw	w	s	f	a	d	t _{max}	D _{min}		MG12	EG55	TH35	TN35	
R/L108.0110.00	1,1	1,19	3,2	4,8	7,8	6	1	8		▲/▲	▲/▲	▲/▲	▲/▲	
R/L108.0130.00	1,3	1,39	3,2	4,8	7,8	6	1	8		▲/▲	▲/▲	▲/▲	▲/▲	
R/L108.0160.00	1,6	1,69	3,2	4,8	7,8	6	1	8		▲/▲	▲/▲	▲/▲	▲/▲	
▲ ab Lager / on stock Δ 4 Wochen / 4 weeks x auf Anfrage / upon request										P	o	•	•	•
● empfohlen / recommended										M	-	o	•	•
o bedingt einsetzbar / alternative recommendation										K	-	o	•	•
- nicht geeignet / not suitable										N	-	-	•	•
■ unbeschichtete HM-Sorten / uncoated grades										S	-	-	•	•
■ beschichtete HM-Sorten / coated grades										H	-	-	-	-
■ bestückt/Cermet / brazed/Cermet														

Abmessungen in mm
Dimensions in mm

Ausführung R oder L angeben
State R or L version

Weitere Abmessungen auf Anfrage
Further sizes upon request

HM-Sorten
Carbide grades

NC-Feindrehen (innen)

NC-Profiling (internal)



Schneidplatte

Insert

108

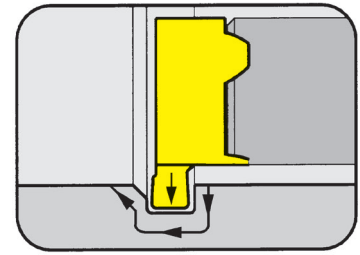

Bohrungs-Ø ab Stechtiefe	Bore Ø from Depth of groove	8 mm 1 mm
-----------------------------	--------------------------------	--------------

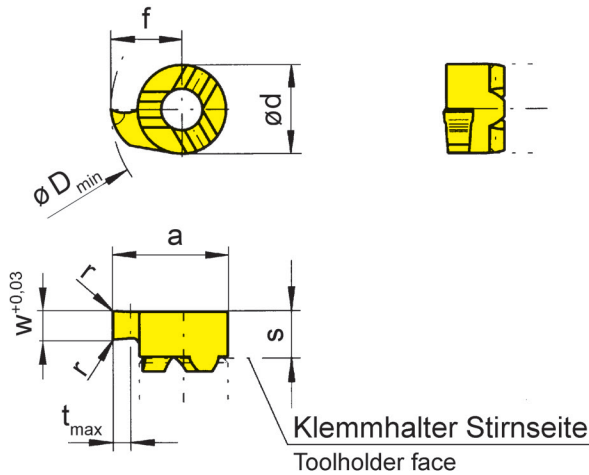

für Klemmhalter
for Toolholder

Typ B108
Type



R = rechts wie gezeichnet
R = right hand version shown

L = links spiegelbildlich
L = left hand version

Bestellnummer Part number	w	s	f	a	r	d	t _{max}	D _{min}	MG12	EG55	TH35	TI25	TN35
R/L108.0150.02	1,5	3,2	4,8	7,8	0,2	6	1	8	▲/▲	▲/▲	▲/▲	▲/▲	▲/▲

▲ ab Lager / on stock Δ 4 Wochen / 4 weeks x auf Anfrage / upon request

● empfohlen / recommended

o bedingt einsetzbar / alternative recommendation

- nicht geeignet / not suitable

■ unbeschichtete HM-Sorten / uncoated grades

■ beschichtete HM-Sorten / coated grades

■ bestückt/Cermet / brazed/Cermet

Abmessungen in mm

Dimensions in mm

Ausführung R oder L angeben

State R or L version

Weitere Abmessungen auf Anfrage

Further sizes upon request

P	o	●	●	●	●
M	-	o	●	●	●
K	-	o	●	●	●
N	-	-	●	●	●
S	-	-	●	●	●
H	-	-	-	-	-

HM-Sorten
Carbide grades

Einstecken (innen)

Grooving (internal)



Schneidplatte

Insert

108

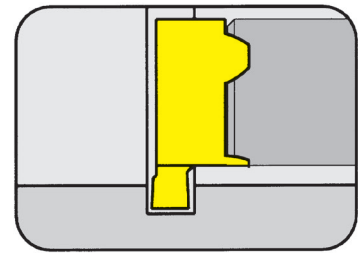

Bohrungs-Ø ab Stechbreite	Bore Ø from Width of groove	8 mm 1,5-2 mm
------------------------------	--------------------------------	------------------

B

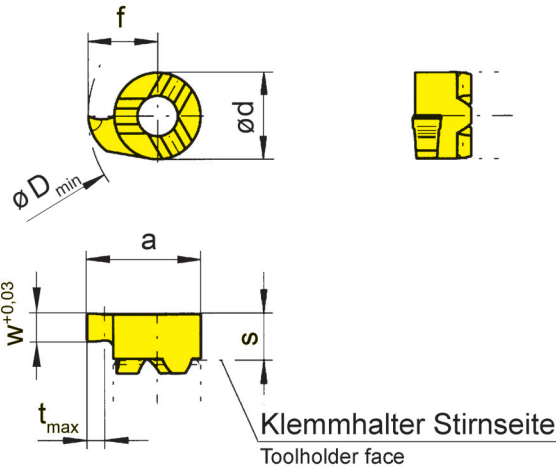

für Klemmhalter
for Toolholder

Typ B108
Type

R = rechts wie gezeichnet
R = right hand version shown

L = links spiegelbildlich
L = left hand version

Bestellnummer Part number	w	s	f	a	d	t _{max}	D _{min}	MG12	EG55	TH35	TN35
R/L108.0150.00	1,5	3,2	4,8	7,8	6	1	8	▲/▲	▲/▲	▲/▲	▲/▲
R/L108.0200.00	2,0	3,2	4,8	7,8	6	1	8	▲/▲	▲/▲	▲/▲	▲/▲

- ▲ ab Lager / on stock Δ 4 Wochen / 4 weeks x auf Anfrage / upon request
- empfohlen / recommended
- o bedingt einsetzbar / alternative recommendation
- nicht geeignet / not suitable
- unbeschichtete HM-Sorten / uncoated grades
- beschichtete HM-Sorten / coated grades
- bestückt/Cermet / brazed/Cermet

	MG12	EG55	TH35	TN35
P	o	•	•	•
M	-	o	•	•
K	-	o	•	•
N	-	-	•	•
S	-	-	•	•
H	-	-	-	-

HM-Sorten
Carbide grades

Abmessungen in mm
Dimensions in mm

Ausführung R oder L angeben
State R or L version

Weitere Abmessungen auf Anfrage
Further sizes upon request

Einstecken (innen)

Grooving (internal)



Schneidplatte

Insert

S108

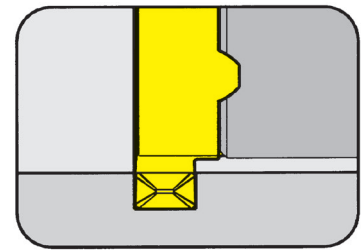

Bohrungs-Ø ab	Bore Ø from	8 mm
Stechtiefe bis	Depth of groove up to	1 mm
Stechbreite	Width of groove	1-2 mm

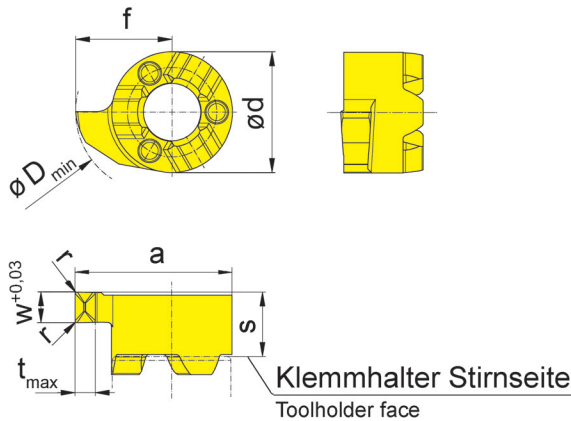

für Klemmhalter
for Toolholder

Typ B108
Type

R = rechts wie gezeichnet
R = right hand version shown

L = links spiegelbildlich
L = left hand version

Geometrie .D
Geometry .D

Bestellnummer Part number	w	s	f	a	r	d	t _{max}	D _{min}	EG55	TH35
R/LS108.0100.D1	1,0	3,2	4,8	7,8	0,1	6	1	8	▲/Δ	▲/▲
R/LS108.0150.D1	1,5	3,2	4,8	7,8	0,1	6	1	8	▲/Δ	▲/Δ
R/LS108.0200.D2	2,0	3,2	4,8	7,8	0,2	6	1	8	▲/Δ	▲/▲

▲ ab Lager / on stock Δ 4 Wochen / 4 weeks x auf Anfrage / upon request

● empfohlen / recommended

o bedingt einsetzbar / alternative recommendation

- nicht geeignet / not suitable

■ unbeschichtete HM-Sorten / uncoated grades

■ beschichtete HM-Sorten / coated grades

■ bestückt/Cermet / brazed/Cermet

Abmessungen in mm

Dimensions in mm

Ausführung R oder L angeben

State R or L version

Weitere Abmessungen auf Anfrage

Further sizes upon request

P	●	●
M	○	●
K	○	●
N	-	●
S	-	●
H	-	-

HM-Sorten
Carbide grades



Einstecken (innen)

Grooving (internal)



Schneidplatte

Insert

108

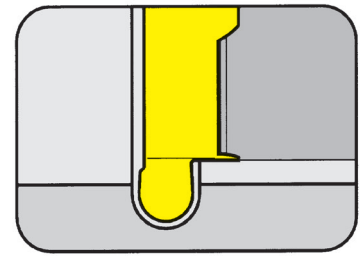

Bohrungs-Ø ab Vollradius	Bore Ø from Full radius	8 mm 0,4-0,9 mm
--------------------------	-------------------------	--------------------

B

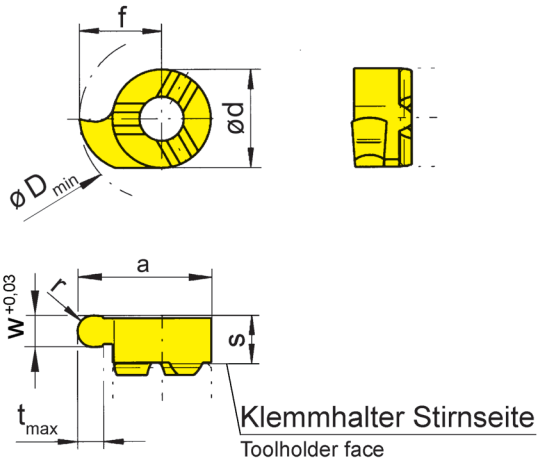

für Klemmhalter
for Toolholder

Typ B108
Type

Vollradius
Full radius

R = rechts wie gezeichnet
R = right hand version shown

L = links spiegelbildlich
L = left hand version

Bestellnummer Part number	w	s	f	a	d	r	t _{max}	D _{min}	HM-Sorten				
									MG12	EG55	TH35	TI25	TN35
R/L108.0004.08	0,8	3,2	4,8	7,8	6	0,4	1	8	▲/Δ	▲/▲	▲/▲	▲/Δ	▲/▲
R/L108.0006.12	1,2	3,2	4,8	7,8	6	0,6	1	8	▲/▲	▲/▲	▲/▲	▲/Δ	▲/▲
R/L108.0009.18	1,8	3,2	4,8	7,8	6	0,9	1	8	▲/Δ	▲/▲	▲/▲	▲/Δ	▲/▲

▲ ab Lager / on stock Δ 4 Wochen / 4 weeks x auf Anfrage / upon request

● empfohlen / recommended

o bedingt einsetzbar / alternative recommendation

- nicht geeignet / not suitable

■ unbeschichtete HM-Sorten / uncoated grades

■ beschichtete HM-Sorten / coated grades

■ bestückt/Cermet / brazed/Cermet

Abmessungen in mm

Dimensions in mm

Ausführung R oder L angeben

State R or L version

Weitere Abmessungen auf Anfrage

Further sizes upon request

	MG12	EG55	TH35	TI25	TN35
P	o	●	●	●	●
M	-	o	●	●	●
K	-	o	●	●	●
N	-	-	●	●	●
S	-	-	●	●	●
H	-	-	-	-	-

HM-Sorten
Carbide grades

Schneidplatte

Insert

108

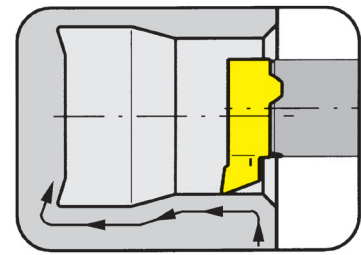

Bohrungs-Ø ab	Bore Ø from	7,8 mm
---------------	-------------	--------

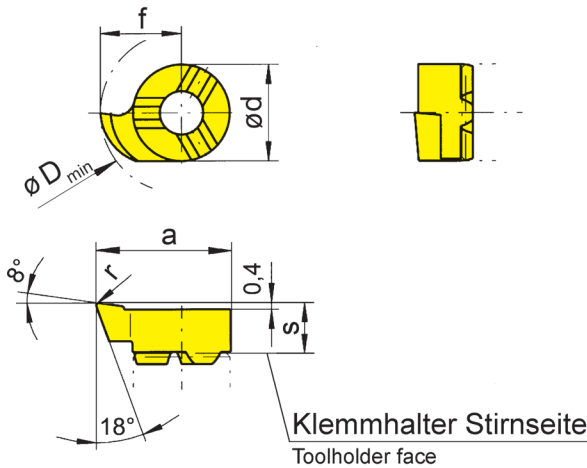

für Klemmhalter
for Toolholder

Typ B108
Type

R = rechts wie gezeichnet
R = right hand version shown

L = links spiegelbildlich
L = left hand version

Bestellnummer Part number	s	f	a	r	d	D _{min}	MG12	EG55	TF45	TH35	TI25	TN35
R/L108.1846.02	3,4	4,65	7,65	0,2	6	7,8	▲/▲	▲/▲	Δ/x	▲/▲	▲/▲	▲/▲
▲ ab Lager / on stock							P	o	•	•	•	•
● empfohlen / recommended							M	-	o	•	•	•
o bedingt einsetzbar / alternative recommendation							K	-	o	•	•	•
- nicht geeignet / not suitable							N	-	-	•	•	•
unbeschichtete HM-Sorten / uncoated grades							S	-	-	•	•	•
beschichtete HM-Sorten / coated grades							H	-	-	-	-	-
bestückt/Cermet / brazed/Cermet												

Abmessungen in mm
Dimensions in mm

Ausführung R oder L angeben
State R or L version

Die besondere Schneidengeometrie erlaubt das Ausdrehen von Bohrungen $\geq \varnothing 7,8$ mm und das Kopieren von Freistichen gemäß DIN 509 Form E und F.

The modified geometry allows boring of bores $\geq \varnothing 7,8$ mm and profiling of reliefs as per DIN 509 form E and F.

Weitere Abmessungen auf Anfrage
Further sizes upon request

HM-Sorten
Carbide grades



Schneidplatte

Insert

S108

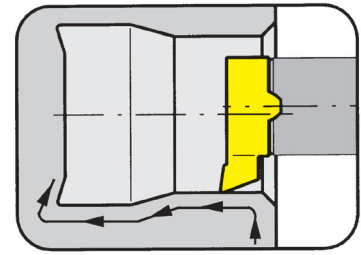

Bohrungs-Ø ab	Bore Ø from	7,8 mm
---------------	-------------	--------

B

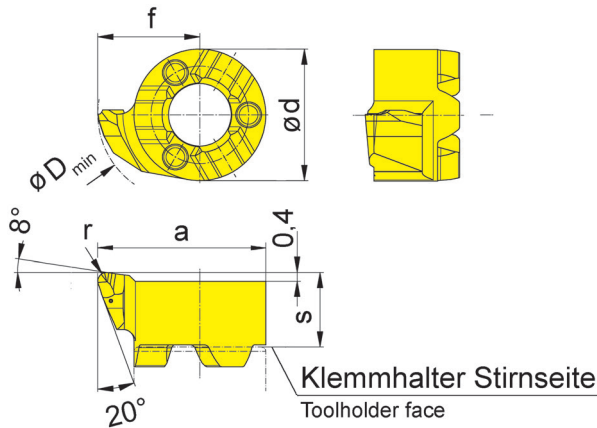

für Klemmhalter
for Toolholder

Typ B108
Type

Geometrie .R
Geometry .R

R = rechts wie gezeichnet
R = right hand version shown

L = links spiegelbildlich
L = left hand version

Bestellnummer Part number	s	f	a	r	d	D _{min}		EG55	TH35
R/LS108.1846.R2	3,4	4,65	7,65	0,2	6	7,8	▲/▲	▲/▲	▲/▲
R/LS108.1846.R4	3,4	4,65	7,65	0,4	6	7,8	▲/▲	▲/▲	▲/▲
▲ ab Lager / on stock								P ●	●
● empfohlen / recommended								M ○	●
○ bedingt einsetzbar / alternative recommendation								K ○	●
- nicht geeignet / not suitable								N -	●
■ unbeschichtete HM-Sorten / uncoated grades								S -	●
■ beschichtete HM-Sorten / coated grades								H -	-
■ bestückt/Cermet / brazed/Cermet									

Abmessungen in mm
Dimensions in mm

Ausführung R oder L angeben
State R or L version

Die besondere Schneidengeometrie erlaubt das Ausdrehen von Bohrungen $\geq \varnothing 7,8$ mm und das Kopieren von Freistichen gemäß DIN 509 Form E und F.

The modified geometry allows boring of bores $\geq \varnothing 7,8$ mm and profiling of reliefs as per DIN 509 form E and F.

Weitere Abmessungen auf Anfrage
Further sizes upon request

HM-Sorten
Carbide grades

Rückwärtsdrehen (innen)

Backboring (internal)



Schneidplatte

Insert

108

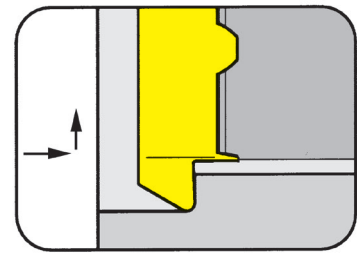

Bohrungs-Ø ab Profiltiefe bis	Bore Ø from Depth of undercut up to	7,8 mm 1,3 mm
----------------------------------	--	------------------

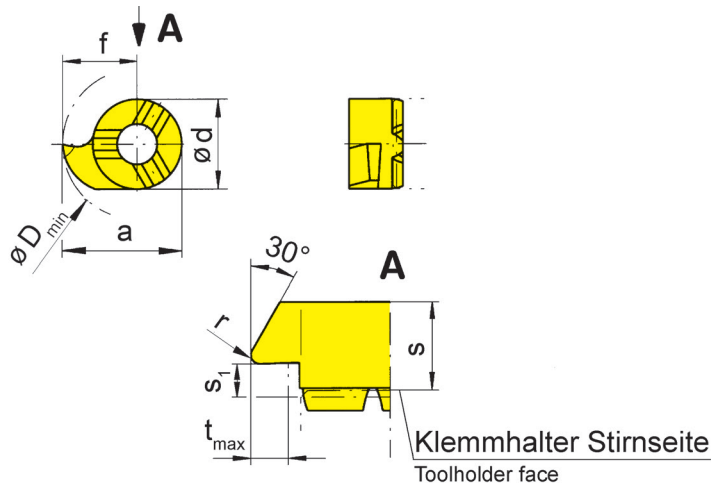

für Klemmhalter
for Toolholder

Typ B108
Type



R = rechts wie gezeichnet
R = right hand version shown

L = links spiegelbildlich
L = left hand version

Bestellnummer Part number	s	f	a	r	s ₁	d	t _{max}	D _{min}	EG55	TH35	TN35
R/L108.3046.02	3,6	4,65	7,65	0,2	0,8	6	1,3	7,8	▲/▲	▲/▲	▲/▲

- ▲ ab Lager / on stock Δ 4 Wochen / 4 weeks x auf Anfrage / upon request
- empfohlen / recommended
- o bedingt einsetzbar / alternative recommendation
- nicht geeignet / not suitable
- unbeschichtete HM-Sorten / uncoated grades
- beschichtete HM-Sorten / coated grades
- bestückt/Cermet / brazed/Cermet

Abmessungen in mm
Dimensions in mm

Ausführung R oder L angeben
State R or L version

Weitere Abmessungen auf Anfrage
Further sizes upon request

P	●	●	●
M	o	●	●
K	o	●	●
N	-	●	●
S	-	●	●
H	-	-	-

HM-Sorten
Carbide grades

Schneidplatte

Insert

108

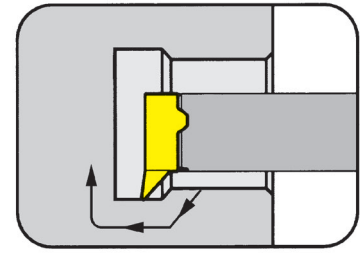

Bohrungs-Ø ab Profiltiefe bis	Bore Ø from Depth of undercut up to	7,8 mm 1,2 mm
----------------------------------	--	------------------

B

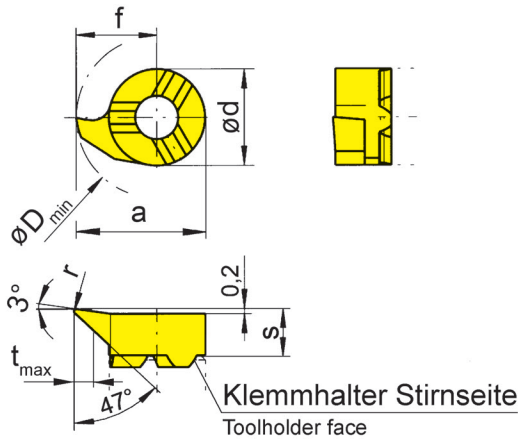

für Klemmhalter
for Toolholder

Typ B108
Type

R = rechts wie gezeichnet
R = right hand version shown

L = links spiegelbildlich
L = left hand version

Bestellnummer Part number	s	f	a	r	d	t _{max}	D _{min}	MG12	EG55	TH35	TN35
R/L108.4748.01	3,2	4,65	7,65	0,1	6	1,2	7,8		▲/▲	▲/▲	
R/L108.4748.02	3,2	4,65	7,65	0,2	6	1,2	7,8	Δ/x	▲/▲	▲/▲	▲/▲
R/L108.4748.04	3,2	4,65	7,65	0,4	6	1,2	7,8		▲/▲	▲/▲	
								P	o	•	•
								M	-	o	•
								K	-	o	•
								N	-	-	•
								S	-	-	•
								H	-	-	-

- ▲ ab Lager / on stock Δ 4 Wochen / 4 weeks x auf Anfrage / upon request
- empfohlen / recommended
- o bedingt einsetzbar / alternative recommendation
- nicht geeignet / not suitable
- unbeschichtete HM-Sorten / uncoated grades
- beschichtete HM-Sorten / coated grades
- bestückt/Cermet / brazed/Cermet

Abmessungen in mm
Dimensions in mm

Ausführung R oder L angeben
State R or L version

Die besondere Schneidengeometrie erlaubt das Ausdrehen von Bohrungen ≥ Ø 7,8 mm und das Kopieren von Freistichen gemäß DIN 509 Form E.

The modified geometry allows boring of bores ≥ Ø 7,8 mm and profiling of reliefs as per DIN 509 form E.

Weitere Abmessungen auf Anfrage
Further sizes upon request

HM-Sorten
Carbide grades

Fasen und Rückwärtsdrehen (innen)

Chamfering and Backboring (internal)



Schneidplatte

108

Insert

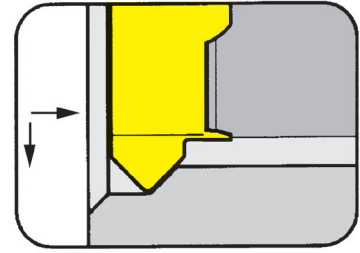

Bohrungs-Ø ab Schnittiefe bis	Bore Ø from Depth of cut up to	7,8 mm 1,4 mm
----------------------------------	-----------------------------------	------------------

für Klemmhalter
for Toolholder

Typ B108
Type

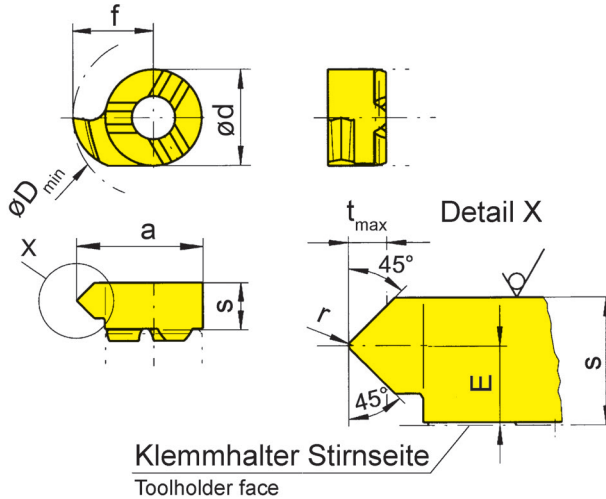

Klemmhalter Stirnseite
Toolholder face

R = rechts wie gezeichnet
R = right hand version shown

L = links spiegelbildlich
L = left hand version

Bestellnummer Part number	E	s	f	a	d	r	α	t_{max}	D_{min}	EG55	TA45	TI25	TN35
R/L108.4545.02	1,8	3,6	4,65	7,65	6	0,2	45°	1,4	7,8	▲/▲	▲/▲	▲/▲	▲/▲

▲ ab Lager / on stock Δ 4 Wochen / 4 weeks x auf Anfrage / upon request

● empfohlen / recommended

o bedingt einsetzbar / alternative recommendation

- nicht geeignet / not suitable

■ unbeschichtete HM-Sorten / uncoated grades

■ beschichtete HM-Sorten / coated grades

■ bestückt/Cermet / brazed/Cermet

P	●	●	●	●
M	o	●	●	●
K	o	●	●	●
N	-	●	●	●
S	-	●	●	●
H	-	-	-	-

HM-Sorten
Carbide grades

Abmessungen in mm

Dimensions in mm

Ausführung R oder L angeben

State R or L version

Weitere Abmessungen auf Anfrage

Further sizes upon request

Vorstechen und Fasen (innen)

Pregrooving and Chamfering (internal)



Schneidplatte

108

Insert

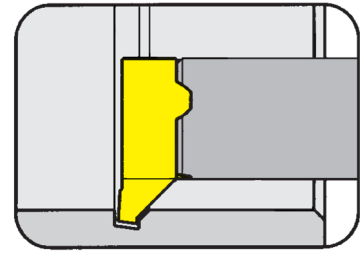

Bohrungs-Ø ab	Bore Ø from	8 mm
---------------	-------------	------

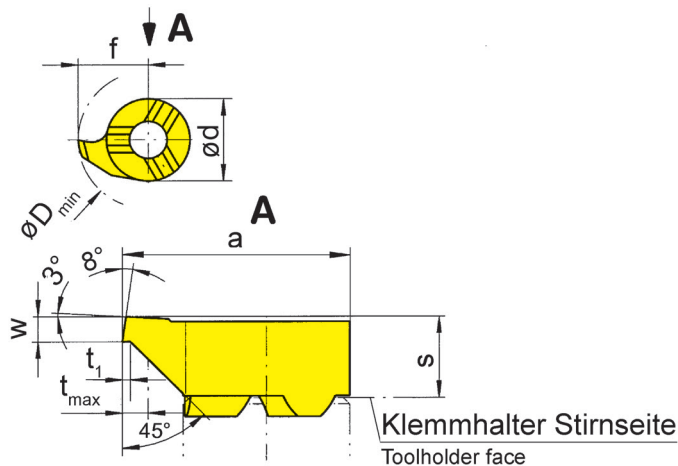

für Klemmhalter
for Toolholder

Typ B108
Type

B

R = rechts wie gezeichnet
R = right hand version shown

L = links spiegelbildlich
L = left hand version

Bestellnummer Part number	w	s	f	a	d	t _{max}	t _i	D _{min}		MG12	EG55	Ti25	TN35
R/L108.0810.45	1	3,2	4,8	7,8	6	1,5	0,2	8		▲/▲	▲/▲	▲/▲	▲/▲

- ▲ ab Lager / on stock Δ 4 Wochen / 4 weeks x auf Anfrage / upon request
- empfohlen / recommended
- o bedingt einsetzbar / alternative recommendation
- nicht geeignet / not suitable
- unbeschichtete HM-Sorten / uncoated grades
- beschichtete HM-Sorten / coated grades
- bestückt/Cermet / brazed/Cermet

P	o	●	●	●
M	-	o	●	●
K	-	o	●	●
N	-	-	●	●
S	-	-	●	●
H	-	-	-	-

HM-Sorten
Carbide grades

Abmessungen in mm
Dimensions in mm

Ausführung R oder L angeben
State R or L version

Weitere Abmessungen auf Anfrage
Further sizes upon request

Gewindedrehen (innen) Teilprofil

Threading (internal) Partial profile



Schneidplatte

Insert

108

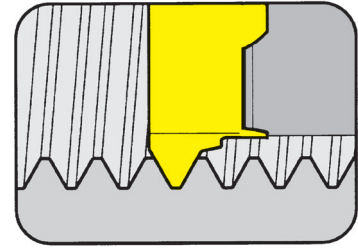

Bohrungs-Ø ab Steigung	Bore Ø from Pitch	8 mm 0,5-1,25 mm
------------------------	-------------------	---------------------

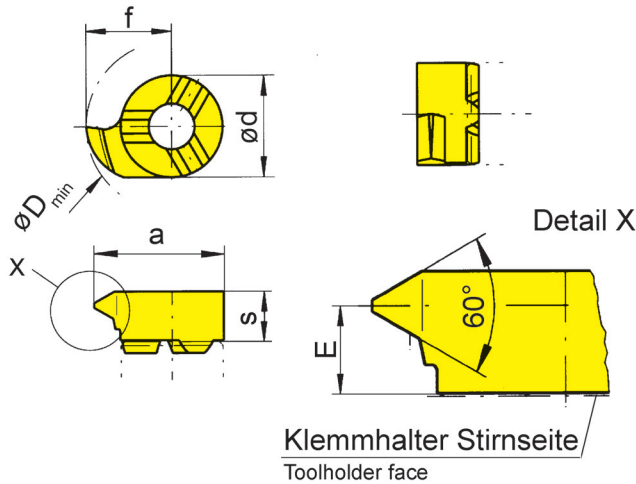

für Klemmhalter
for Toolholder

Typ B108
Type



Metrisches ISO-Gewinde
Metric ISO-thread

R = rechts wie gezeichnet
R = right hand version shown

L = links spiegelbildlich
L = left hand version

Bestellnummer Part number	P	P _{max}	E	f	a	d	s	D _{min}	MG12	EG55	TH35	TI25	TN35
R/L108.0205.01	0,5	0,75	2,8	4,8	7,8	6	3,6	8	▲/▲	▲/▲	▲/▲	▲/▲	▲/▲
R/L108.0510.01	1,0	1,25	2,8	4,8	7,8	6	3,6	8	▲/▲	▲/▲	▲/▲	▲/▲	▲/▲

- ▲ ab Lager / on stock Δ 4 Wochen / 4 weeks x auf Anfrage / upon request
- empfohlen / recommended
- o bedingt einsetzbar / alternative recommendation
- nicht geeignet / not suitable
- unbeschichtete HM-Sorten / uncoated grades
- beschichtete HM-Sorten / coated grades
- bestückt/Cermet / brazed/Cermet

P	o	●	●	●	●
M	-	o	●	●	●
K	-	o	●	●	●
N	-	-	●	●	●
S	-	-	●	●	●
H	-	-	-	-	-

HM-Sorten
Carbide grades

Abmessungen in mm
Dimensions in mm

Ausführung R oder L angeben
State R or L version

Weitere Abmessungen auf Anfrage
Further sizes upon request

Gewindedrehen (innen) Teilprofil

Threading (internal) Partial profile



Schneidplatte

Insert

108

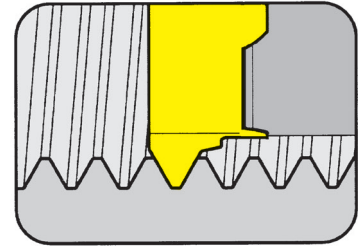

Bohrungs-Ø ab Steigung	Bore Ø from Pitch	8 mm 1,5-1,75 mm
------------------------	-------------------	---------------------

B

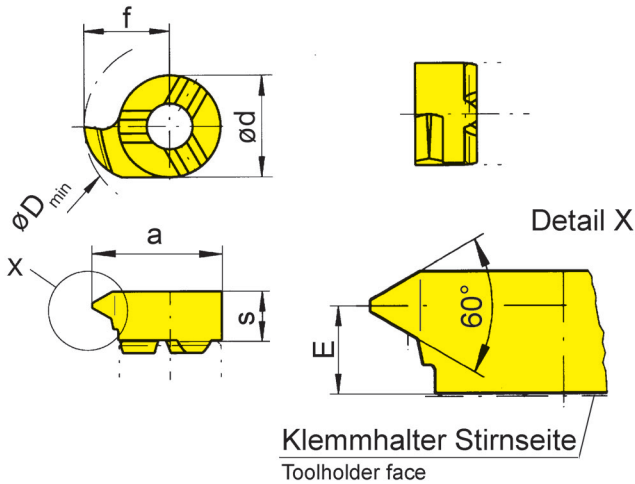

für Klemmhalter
for Toolholder

Typ B108
Type

Metrisches ISO-Gewinde
Metric ISO-thread

R = rechts wie gezeichnet
R = right hand version shown

L = links spiegelbildlich
L = left hand version

Bestellnummer Part number	P	P _{max}	E	f	a	d	s	D _{min}	MG12	EG55	TH35	TN35
R/L108.0815.01	1,5	1,75	2,6	4,8	7,8	6	3,6	8	▲/▲	▲/▲	▲/▲	▲/▲

- ▲ ab Lager / on stock Δ 4 Wochen / 4 weeks x auf Anfrage / upon request
- empfohlen / recommended
- o bedingt einsetzbar / alternative recommendation
- nicht geeignet / not suitable
- unbeschichtete HM-Sorten / uncoated grades
- beschichtete HM-Sorten / coated grades
- bestückt/Cermet / brazed/Cermet

P	o	●	●	●
M	-	o	●	●
K	-	o	●	●
N	-	-	●	●
S	-	-	●	●
H	-	-	-	-

HM-Sorten
Carbide grades

Abmessungen in mm
Dimensions in mm

Ausführung R oder L angeben
State R or L version

Weitere Abmessungen auf Anfrage
Further sizes upon request

Gewindedrehen (innen) Vollprofil

Threading (internal) Full profile



Schneidplatte

Insert

108

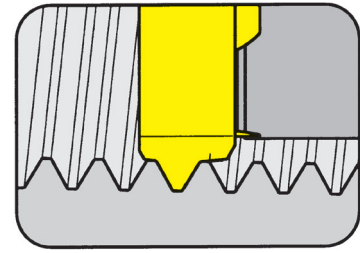

Gang pro Zoll	Threads per inch	18-20
---------------	------------------	-------

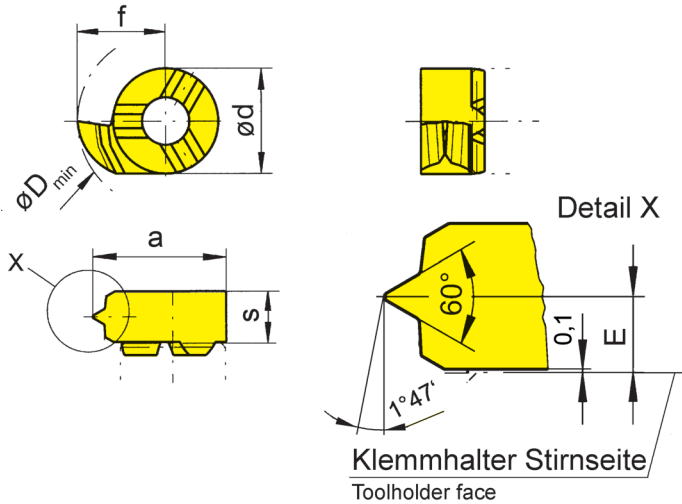

für Klemmhalter
for Toolholder

Typ B108
Type



Gewinde NPT
Thread NPT

R = rechts wie gezeichnet
R = right hand version shown

Bestellnummer Part number	TPI	E	f	d	s	D _{min}	EG55	TI25	TN35	
R108.NP14.02	14	1,9	4,8	6	3,6	8	▲		▲	
R108.NP18.02	18	1,9	4,8	6	3,6	8	▲	x	▲	
R108.NP27.02	27	1,9	4,8	6	3,6	8	Δ		▲	
							P	•	•	•
							M	o	•	•
							K	o	•	•
							N	-	•	•
							S	-	•	•
							H	-	-	-

- ▲ ab Lager / on stock Δ 4 Wochen / 4 weeks x auf Anfrage / upon request
- empfohlen / recommended
- o bedingt einsetzbar / alternative recommendation
- nicht geeignet / not suitable
- unbeschichtete HM-Sorten / uncoated grades
- beschichtete HM-Sorten / coated grades
- bestückt/Cermet / brazed/Cermet

Abmessungen in mm
Dimensions in mm

Weitere Abmessungen auf Anfrage
Further sizes upon request

HM-Sorten
Carbide grades

Gewindedrehen (innen) Vollprofil

Threading (internal) Full profile



Schneidplatte

Insert

108

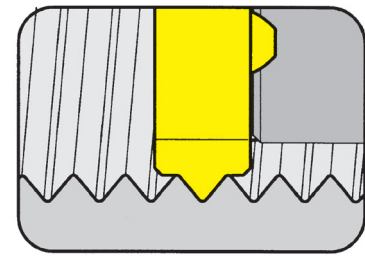

Gang pro Zoll	Threads per inch	18-20
---------------	------------------	-------

B

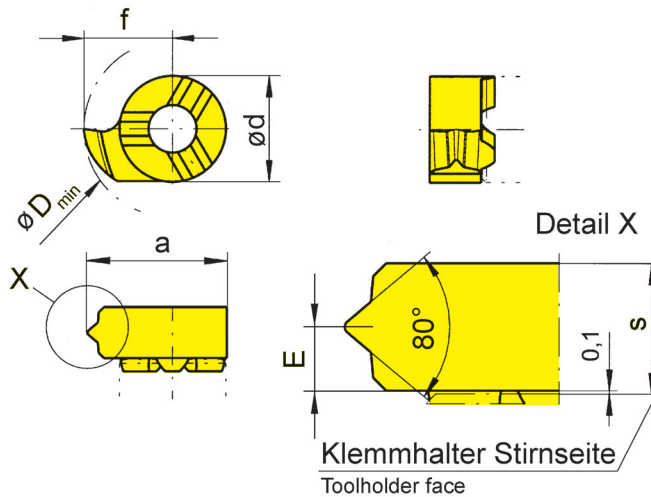

für Klemmhalter
for Toolholder

Typ B108
Type

Stahlpanzerrohrgewinde
Thread profile PG

R = rechts wie gezeichnet
R = right hand version shown

Bestellnummer Part number	TPI	E	f	d	s	D _{min}	EG55	TN35
R108.PG18.02	18	1,9	4,8	6	3,6	8	▲	▲
R108.PG20.02	20	1,9	4,8	6	3,6	8	▲	▲

- ▲ ab Lager / on stock Δ 4 Wochen / 4 weeks x auf Anfrage / upon request
- empfohlen / recommended
- o bedingt einsetzbar / alternative recommendation
- nicht geeignet / not suitable
- unbeschichtete HM-Sorten / uncoated grades
- beschichtete HM-Sorten / coated grades
- bestückt/Cermet / brazed/Cermet

Abmessungen in mm
Dimensions in mm

Weitere Abmessungen auf Anfrage
Further sizes upon request

	EG55	TN35
P	●	●
M	o	●
K	o	●
N	-	●
S	-	●
H	-	-

HM-Sorten
Carbide grades

Gewindedrehen (innen) Teilprofil

Threading (internal) Partial profile



Schneidplatte

Insert

S108

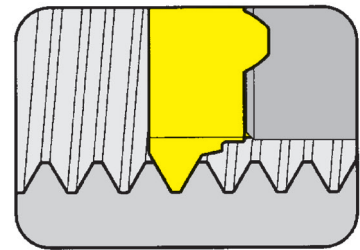

Bohrungs-Ø ab Steigung	Bore Ø from Pitch	8 mm 0,5-1,25 mm
------------------------	-------------------	---------------------

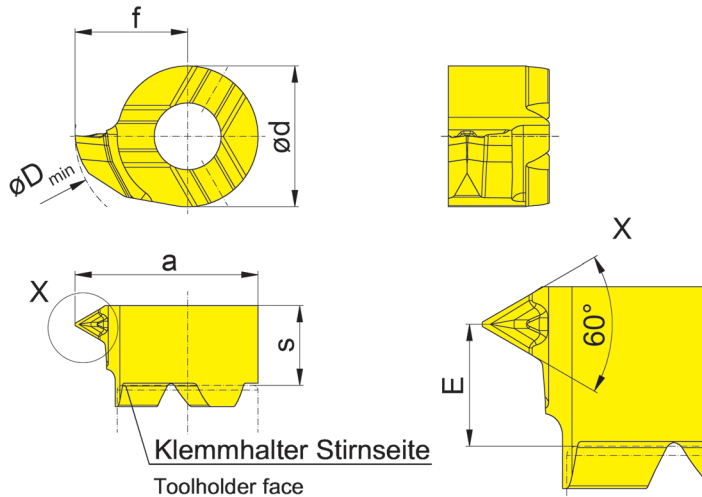

für Klemmhalter
for Toolholder

Typ B108
Type

R = rechts wie gezeichnet
R = right hand version shown

Metrisches ISO-Gewinde
Metric ISO-thread

Bestellnummer Part number	P	P _{max}	E	f	a	d	s	D _{min}	EG55
RS108.0205.GM1	0,5	0,75	2,6	4,8	7,8	6	3,4	8	▲
RS108.0510.GM1	1,0	1,25	2,6	4,8	7,8	6	3,4	8	▲
RS108.0815.GM1	1,5	1,50	2,6	4,8	7,8	6	3,4	8	▲

▲ ab Lager / on stock Δ 4 Wochen / 4 weeks x auf Anfrage / upon request

● empfohlen / recommended

o bedingt einsetzbar / alternative recommendation

- nicht geeignet / not suitable

■ unbeschichtete HM-Sorten / uncoated grades

■ beschichtete HM-Sorten / coated grades

■ bestückt/Cermet / brazed/Cermet

Abmessungen in mm

Dimensions in mm

Weitere Abmessungen auf Anfrage

Further sizes upon request

P	●
M	○
K	○
N	-
S	-
H	-

HM-Sorten
Carbide grades



Gewindedrehen (innen) Vollprofil

Threading (internal) Full profile



Schneidplatte

Insert

S108

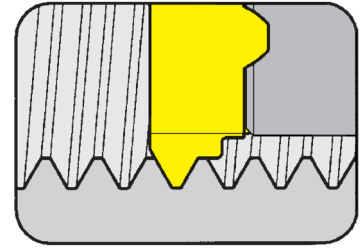

Bohrungs-Ø ab Steigung	Bore Ø from Pitch	8 mm 0,5-1,5 mm
------------------------	-------------------	--------------------

B

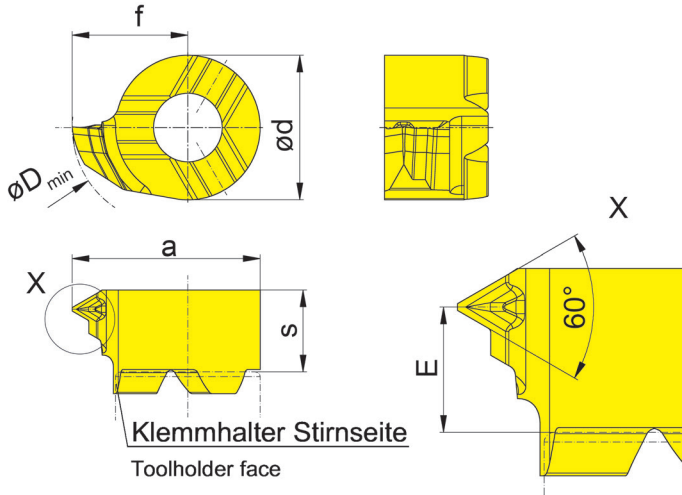

für Klemhalter
for Toolholder

Typ B108
Type

Metrisches ISO-Gewinde
Metric ISO-thread

R = rechts wie gezeichnet
R = right hand version shown

L = links spiegelbildlich
L = left hand version

Bestellnummer Part number	P	E	f	a	d	s	D _{min}	EG55
RS108.0305.GM2	0,50	2,6	4,8	7,8	6	3,4	8	▲
RS108.0510.GM2	1,00	2,6	4,8	7,8	6	3,4	8	▲
RS108.0512.GM2	1,25	2,6	4,8	7,8	6	3,4	8	▲
RS108.0815.GM2	1,50	2,6	4,8	7,8	6	3,4	8	▲

▲ ab Lager / on stock Δ 4 Wochen / 4 weeks x auf Anfrage / upon request

● empfohlen / recommended

o bedingt einsetzbar / alternative recommendation

- nicht geeignet / not suitable

■ unbeschichtete HM-Sorten / uncoated grades

■ beschichtete HM-Sorten / coated grades

■ bestückt/Cermet / brazed/Cermet

Abmessungen in mm

Dimensions in mm

Ausführung R oder L angeben

State R or L version

Weitere Abmessungen auf Anfrage

Further sizes upon request

P	●
M	○
K	○
N	-
S	-
H	-

HM-Sorten
Carbide grades

Das komplette Programm für die Innenbearbeitung finden Sie in unserem Katalog „SUPERMINI UND MINI“.

You will find the complete programme for internal machining in our catalogue „SUPERMINI AND MINI“.



B



100/101



**Schneidenträger mit
Schneidplatten**

Stechbreite 1,2 - 3 mm

Stechtiefe bis 21,5 mm

**Cutter body
with Inserts**

Width of groove 1,2 - 3 mm

Depth of groove up to 21,5 mm

Klemmhalter
Toolholder
H100

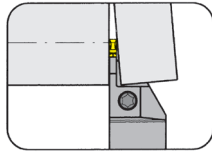

Seite/Page
C3-C8

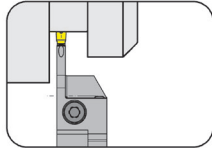

Seite/Page
C9

Klemmhalter Graf
Toolholder Graf
910



Seite/Page
C10-C11

Schneidplatte
Insert
S100

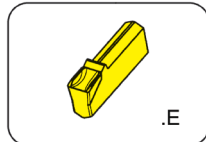

Seite/Page
C12

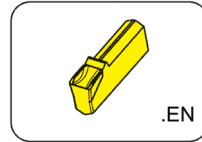

Seite/Page
C13

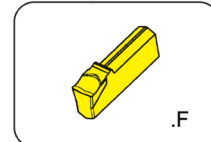

Seite/Page
C14

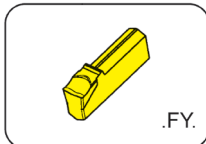

Seite/Page
C15

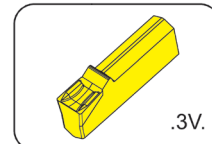

Seite/Page
C16

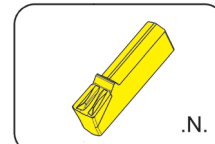

Seite/Page
C17

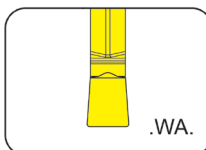

Seite/Page
C18

Klemmhalter
Toolholder
H101

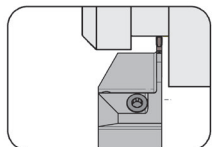

Seite/Page
C19

Schneidplatte
Insert
S101

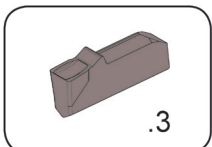

Seite/Page
C20

C

Einstechen und Abstechen

Grooving and Parting Off



Klemmhalter

Toolholder

H100

mit Schraubklemmung
with screwed clamping

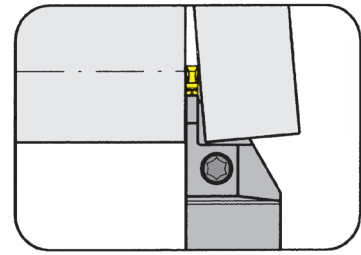

Stechtiefe bis Stechbreite	Depth of groove up to Width of groove	21 mm 2 mm
-------------------------------	--	---------------

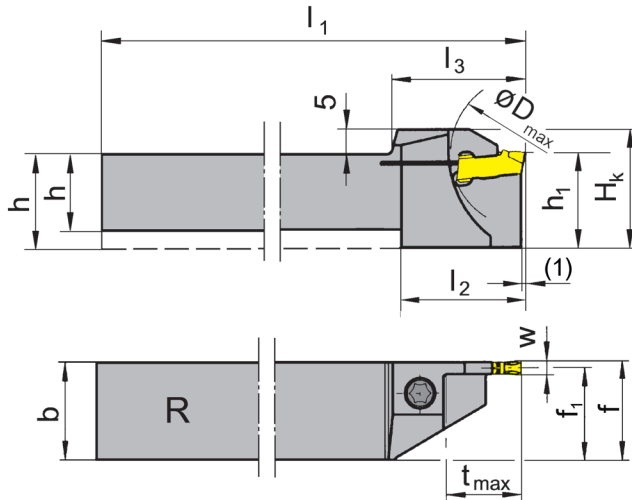

für Schneidplatte
for Insert

Typ S100
Type

R = rechts wie gezeichnet
R = right hand version shown

L = links spiegelbildlich
L = left hand version

Bestellnummer Part number	h	b	l ₁	l ₂	l ₃	h ₁	f ₁	f	t _{max}	D _{max}	H _K	Größe Size
R/LH100.1010.01	10	10	125	19	21,0	13	9,25	f ₁ +w/2	10,5	21	18	01
R/LH100.1010.11	10	10	125	21	23,0	16	9,25	f ₁ +w/2	13,0	42	21	01
R/LH100.1212.01	12	12	125	21	23,0	16	11,25	f ₁ +w/2	13,0	26	21	01
R/LH100.1212.11	12	12	125	21	26,0	16	11,25	f ₁ +w/2	16,0	42	21	01
R/LH100.1616.11	16	16	125	24	26,0	20	15,25	f ₁ +w/2	16,0	42	25	01
R/LH100.1616.21	16	16	125	30	33,5	20	15,25	f ₁ +w/2	21,0	42	25	01

Ausführung R oder L angeben
State R or L version

w siehe Schneidplatten
w see inserts

Abmessungen in mm
Dimensions in mm

Weitere Abmessungen auf Anfrage
Further sizes upon request

Das Anzugsdrehmoment der Schrauben finden Sie in den Technischen Hinweisen.
For torque specification of the screw, please see Technical Instructions.

Ersatzteile

Spare Parts

Klemmhalter Toolholder	Spannschraube Clamping Screw	TORX PLUS®-Schlüssel TORX PLUS® Wrench
R/LH100...	4.15T15P	T15PQ

C

Einstechen und Abstechen

Grooving and Parting Off



Klemmhalter

Toolholder

H100

mit Schraubklemmung
with screwed clamping

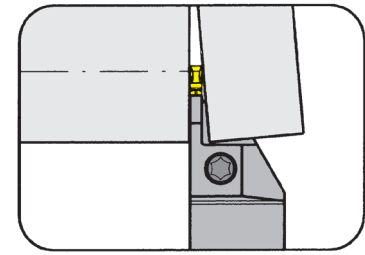

Stechtiefe bis Stechbreite	Depth of groove up to Width of groove	21 mm 2 mm
-------------------------------	--	---------------

für Schneidplatte
for insert

Typ S100
Type

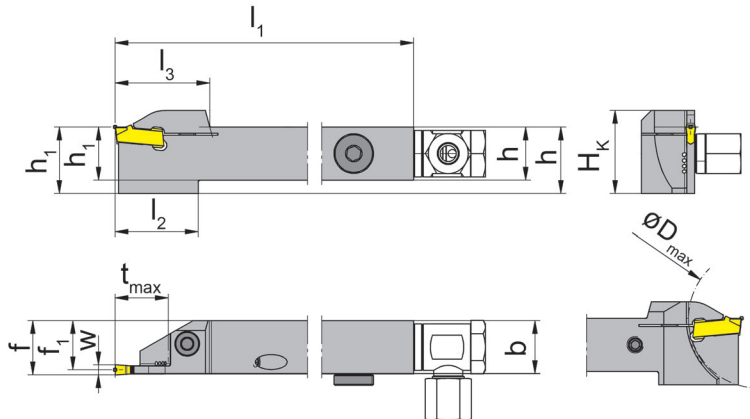

mit innerer
Kühlmittelzufuhr
with through coolant supply

R = rechts wie gezeichnet
R = right hand version shown

L = links spiegelbildlich
L = left hand version

Bestellnummer Part number	h	b	l ₁	l ₂	l ₃	h ₁	f ₁	f	t _{max}	D _{max}	H _k	Größe Size
R/LH100.1212.01.IK	12	12	125	21	23,0	12	11,25	f ₁ +w/2	13	26	21	01
R/LH100.1212.11.IK	12	12	125	21	26,0	12	11,25	f ₁ +w/2	16	42	21	01
R/LH100.1616.11.IK	16	16	125	24	26,0	16	15,25	f ₁ +w/2	16	42	25	01
R/LH100.1616.21.IK	16	16	125	30	33,5	16	15,25	f ₁ +w/2	21	42	25	01

Ausführung R oder L angeben
State R or L version

w siehe Schneidplatten
w see inserts

Abmessungen in mm
Dimensions in mm

Weitere Abmessungen auf Anfrage
Further sizes upon request

Das Anzugsdrehmoment der Schrauben finden Sie in den Technischen Hinweisen.
For torque specification of the screw, please see Technical Instructions.

Ersatzteile

Spare Parts

Klemmhalter Toolholder	Spannschraube Clamping Screw	Kühlmittelanschluss Coolant supply	TORX PLUS®-Schlüssel TORX PLUS® Wrench	Dichtstopfen Sealing plug	Gewindestift Threaded Pin
R/LH100.1212...	4.15T15P	004.00.61	T15PQ		
R/LH100...	4.15T15P	004.00.16	T15PQ	004.00.26	18.05.913

Einstechen und Abstechen

Grooving and Parting Off



Klemmhalter

Toolholder

H100

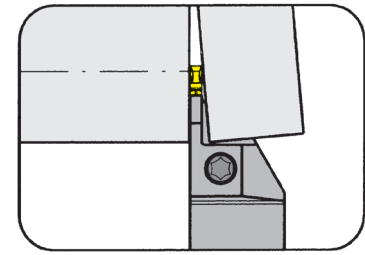

Stechtiefe bis Stechbreite	Depth of groove up to Width of groove	21 mm 2,5 mm
-------------------------------	--	-----------------

für Schneidplatte
for Insert

Typ S100
Type

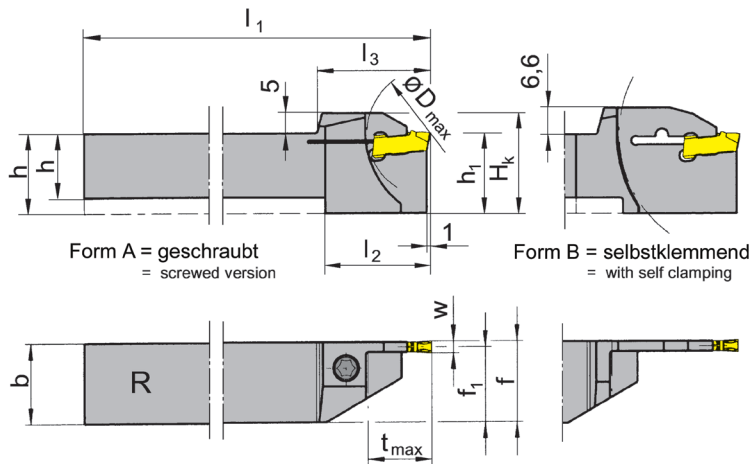

R = rechts wie gezeichnet
R = right hand version shown

L = links spiegelbildlich
L = left hand version

Bestellnummer Part number	h	b	l ₁	l ₂	l ₃	h ₁	f ₁	f	t _{max}	D _{max}	H _K	Form Form	Größe Size
R/LH100.1212.02	12	12	125	21	23,0	16	11,05	f ₁ +w/2	13,0	25	21	A	02
R/LH100.1212.12	12	12	125	24	26,0	16	11,05	f ₁ +w/2	16,0	42	25	A	02
R/LH100.1616.02	16	16	125	19	21,0	20	15,05	f ₁ +w/2	10,5	42	25	A	02
R/LH100.1616.12	16	16	125	24	26,0	20	15,05	f ₁ +w/2	16,0	42	25	A	02
R/LH100.1616.22	16	16	125	30	33,5	20	15,05	f ₁ +w/2	21,0	42	25	A	02

Ausführung R oder L angeben
State R or L version

w siehe Schneidplatten
w see inserts

Abmessungen in mm
Dimensions in mm

Weitere Abmessungen auf Anfrage
Further sizes upon request

Das Anzugsdrehmoment der Schrauben finden Sie in den Technischen Hinweisen.
For torque specification of the screw, please see Technical Instructions.

Ersatzteile

Spare Parts

Klemmhalter Toolholder	Spannschraube Clamping Screw	TORX PLUS®-Schlüssel TORX PLUS® Wrench
R/LH100...	4.15T15P	T15PQ

Klemmhalter

Toolholder

H100

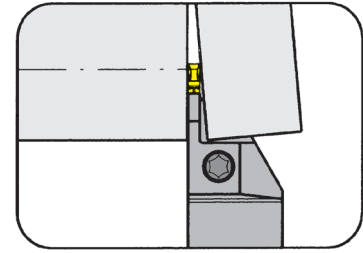

Stechtiefe bis Stechbreite	Depth of groove up to Width of groove	21 mm 2,5 mm
-------------------------------	--	-----------------

für Schneidplatte
for Insert

Typ S100
Type

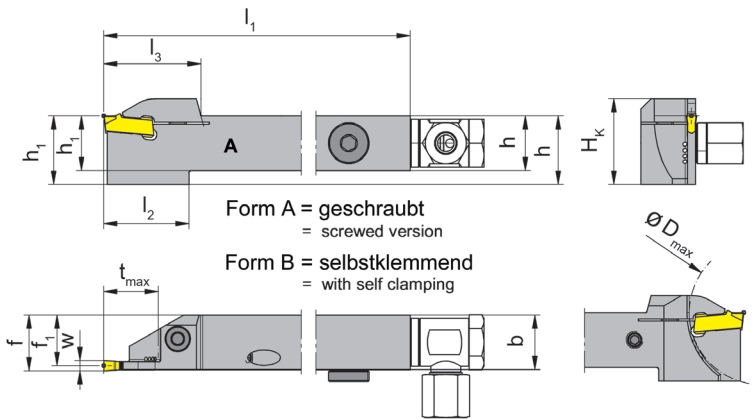

mit innerer
Kühlmittelzufuhr
with through coolant supply

R = rechts wie gezeichnet
R = right hand version shown

L = links spiegelbildlich
L = left hand version

Bestellnummer Part number	h	b	l ₁	l ₂	l ₃	h ₁	f ₁	f	t _{max}	D _{max}	H _K	Form Form	Größe Size
R/LH100.1212.02.IK	12	12	125	21	23,0	16	11,05	f ₁ +w/2	13,0	25	21	A	02
R/LH100.1212.12.IK	12	12	125	24	26,0	16	11,05	f ₁ +w/2	16,0	42	25	A	02
R/LH100.1616.02.IK	16	16	125	19	21,0	20	15,05	f ₁ +w/2	10,5	42	25	A	02
R/LH100.1616.12.IK	16	16	125	24	28,5	20	15,05	f ₁ +w/2	16,0	42	25	A	02
R/LH100.1616.22.IK	16	16	125	30	33,5	20	15,05	f ₁ +w/2	21,0	42	25	A	02

Ausführung R oder L angeben
State R or L version

w siehe Schneidplatten
w see inserts

Abmessungen in mm
Dimensions in mm

Weitere Abmessungen auf Anfrage
Further sizes upon request

Das Anzugsdrehmoment der Schrauben finden Sie in den Technischen Hinweisen.
For torque specification of the screw, please see Technical Instructions.

Ersatzteile

Spare Parts

Klemmhalter Toolholder	Spannschraube Clamping Screw	Kühlmittelanschluss Coolant supply	TORX PLUS®-Schlüssel TORX PLUS® Wrench	Dichtstopfen Sealing plug	Gewindestift Threaded Pin
R/LLH100.1212...	4.15T15P	004.00.61	T15PQ	004.00.26	18.05.913
R/LH100...	4.15T15P	004.00.16	T15PQ	004.00.26	18.05.913

Einstechen und Abstechen

Grooving and Parting Off



Klemmhalter

Toolholder

H100

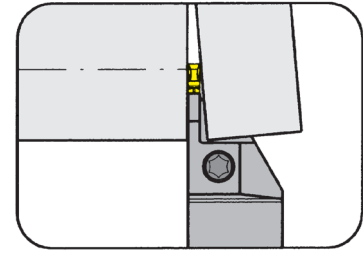

Stechtiefe bis Stechbreite	Depth of groove up to Width of groove	21 mm 3 mm
-------------------------------	--	---------------

für Schneidplatte
for Insert

Typ S100
Type

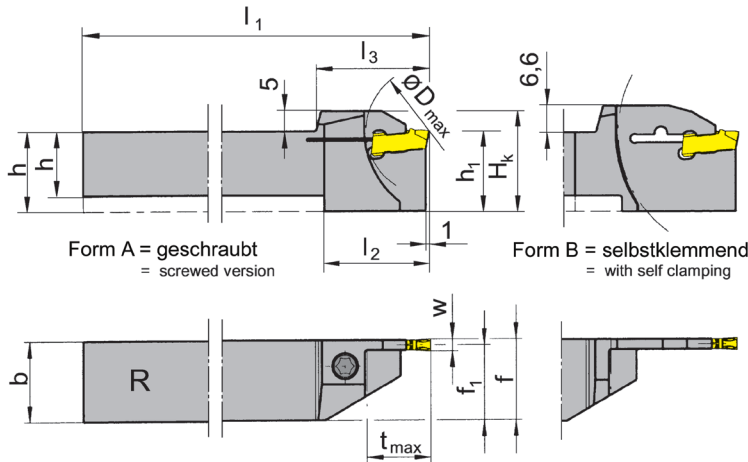

R = rechts wie gezeichnet
R = right hand version shown

L = links spiegelbildlich
L = left hand version

Bestellnummer Part number	h	b	l ₁	l ₂	l ₃	h ₁	f ₁	f	t _{max}	D _{max}	H _k	Form Form	Größe Size
R/LH100.1212.03	12	12	125	21,0	23,0	16	10,85	f ₁ +w/2	13,0	26	25	A	03
R/LH100.1616.03	16	16	125	19,5	23,0	20	14,85	f ₁ +w/2	10,5	42	25	A	03
R/LH100.1616.13	16	16	125	25,0	28,5	20	14,85	f ₁ +w/2	16,0	42	25	A	03
R/LH100.1616.23	16	16	125	30,0	33,5	20	14,85	f ₁ +w/2	21,0	42	25	A	03

Ausführung R oder L angeben
State R or L version

w siehe Schneidplatten
w see inserts

Abmessungen in mm
Dimensions in mm

Weitere Abmessungen auf Anfrage
Further sizes upon request

Das Anzugsdrehmoment der Schrauben finden Sie in den Technischen Hinweisen.
For torque specification of the screw, please see Technical Instructions.

Ersatzteile

Spare Parts

Klemmhalter Toolholder	Spannschraube Clamping Screw	TORX PLUS®-Schlüssel TORX PLUS® Wrench
R/LH100...	5.17T20P	T20PQ

Einstechen und Abstechen

Grooving and Parting Off



Klemmhalter

Toolholder

H100

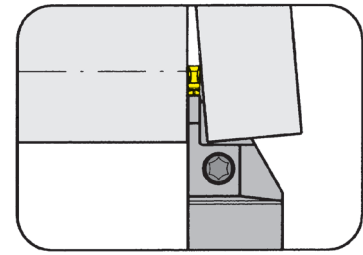

Stechtiefe bis Stechbreite	Depth of groove up to Width of groove	21 mm 3 mm
-------------------------------	--	---------------

für Schneidplatte
for Insert

Typ S100
Type

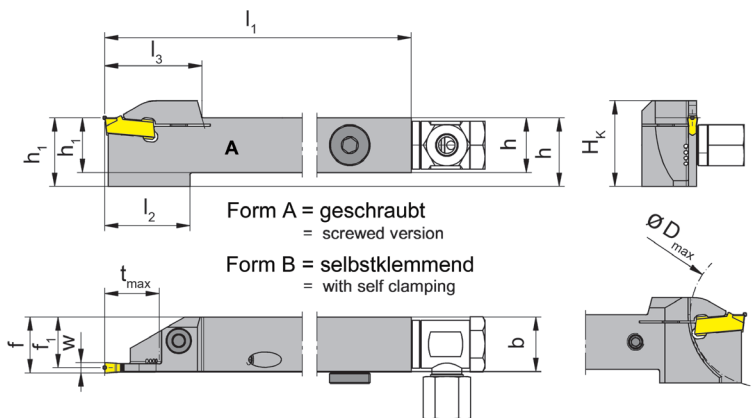

mit innerer
Kühlmittelzufuhr
with through coolant supply

R = rechts wie gezeichnet
R = right hand version shown

L = links spiegelbildlich
L = left hand version

Bestellnummer Part number	h	b	l ₁	l ₂	l ₃	h ₁	f ₁	f	t _{max}	D _{max}	H _k	Form Form	Größe Size
R/LH100.1212.03.IK	12	12	125	21,0	23,0	16	10,85	f ₁ +w/2	13,0	26	25	A	03
R/LH100.1616.03.IK	16	16	125	19,5	23,0	20	14,85	f ₁ +w/2	10,5	42	25	A	03
R/LH100.1616.13.IK	16	16	125	25,0	28,5	20	14,85	f ₁ +w/2	16,0	42	25	A	03
R/LH100.1616.23.IK	16	16	125	30,0	33,5	20	14,85	f ₁ +w/2	21,0	42	25	A	03

Ausführung R oder L angeben
State R or L version

w siehe Schneidplatten
w see inserts

Abmessungen in mm
Dimensions in mm

Weitere Abmessungen auf Anfrage
Further sizes upon request

Das Anzugsdrehmoment der Schrauben finden Sie in den Technischen Hinweisen.
For torque specification of the screw, please see Technical Instructions.

Ersatzteile

Spare Parts

Klemmhalter Toolholder	Spannschraube Clamping Screw	Kühlmittel- anschluss Coolant supply	TORX PLUS®- Schlüssel TORX PLUS® Wrench	Dichtstopfen Sealing plug	Gewindestift Threaded Pin	Verschluss- schraube Screw Plug
R/LH100.1212.03.IK	5.17T20P	004.00.61	T20PQ			
R/LH100...	5.17T20P	004.00.16	T20PQ	004.00.26	18.05.913	
R/LH100.1616.23.IK	4.15T15P	004.00.16	T20PQ	004.00.26	18.05.913	18.908

Einstecken und Abstechen

Grooving and Parting Off



Klemmhalter

Toolholder

H100

mit Schraubklemmung
with screwed clamping

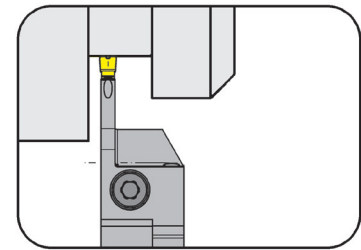

Stechtiefe bis Stechbreite	Depth of groove up to Width of groove	21,5 mm 3 mm
-------------------------------	--	-----------------

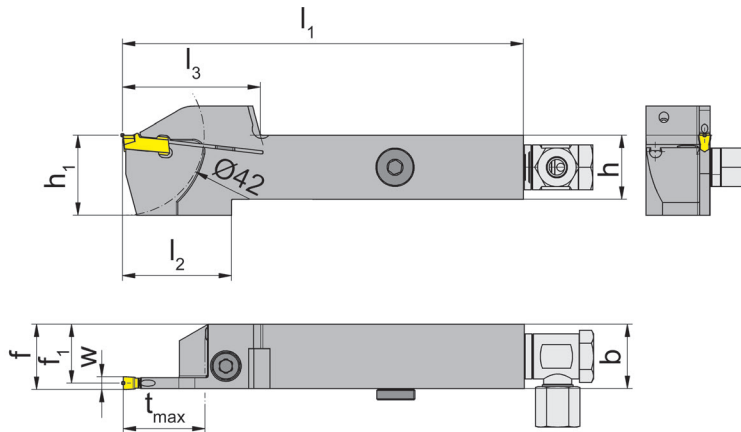

für Schneidplatte
for insert

Typ S100
Type

R = rechts wie gezeichnet
R = right hand version shown

L = links spiegelbildlich
L = left hand version

mit innerer
Kühlmittelzufuhr
with through coolant supply

Bestellnummer Part number	h	b	l ₁	l ₂	l ₃	h ₁	f ₁	f	t _{max}	Größe Size
R/LH100.1616.0.23.IK	16	16	125	35	39	25	14,65	f ₁ +w/2	21,5	03

Ausführung R oder L angeben
State R or L version

w siehe Schneidplatten
w see inserts

Abmessungen in mm
Dimensions in mm

Weitere Abmessungen auf Anfrage
Further sizes upon request

Das Anzugsdrehmoment der Schrauben finden Sie in den Technischen Hinweisen.
For torque specification of the screw, please see Technical Instructions.

Ersatzteile

Spare Parts

Klemmhalter Toolholder	Dichtstopfen Sealing plug	Gewindestift Threaded Pin	Kühlmittelanschluss Coolant supply	Spannschraube Clamping Screw	TORX PLUS®-Schlüssel TORX PLUS® Wrench
R/LH100.1616.0.23.IK	004.00.26	18.05.913	004.00.16	6.23T25P	T25PQ

Einstechen und Abstechen

Grooving and Parting Off



Klemmhalter

Toolholder

910

mit Schraubklemmung
with screwed clamping



Stechbreite	Width of groove	2-2,2 mm
-------------	-----------------	----------

für Schneidplatte
for insert

Typ S100
Type

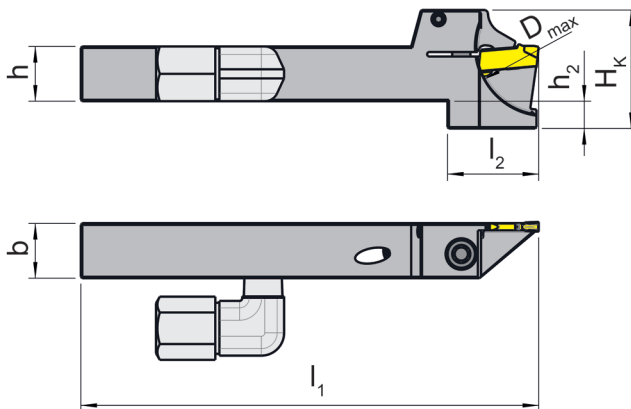

R = rechts wie gezeichnet
R = right hand version shown

L = links spiegelbildlich
L = left hand version

mit innerer
Kühlmittelzufuhr
with through coolant supply

Bestellnummer Part number	h	b	l ₁	l ₂	H _k	h ₂	D _{max}	Größe Size
910.L.1012.01.2IK	10	12	100	20	24	6	20	01
910.R.1012.01.2IK	10	12	100	20	24	6	20	01
910.L.1212.01.2IK	12	12	100	20	26	6	26	01
910.R.1212.01.2IK	12	12	100	20	26	6	26	01
910.L.1616.01.2IK	16	16	100	25	34	10	42	01
910.R.1616.01.2IK	16	16	100	25	34	10	42	01

Abmessungen in mm
Dimensions in mm

Weitere Abmessungen auf Anfrage
Further sizes upon request

Ersatzteile

Spare Parts

Klemmhalter Toolholder	Kühlmittelanschluss Coolant supply
910...	004.00.22

Einstechen und Abstechen

Grooving and Parting Off



Klemmhalter

Toolholder

910

mit Schraubklemmung
with screwed clamping



Stechbreite	Width of groove	2,5-3 mm
-------------	-----------------	----------

für Schneidplatte
for Insert

Typ S100
Type

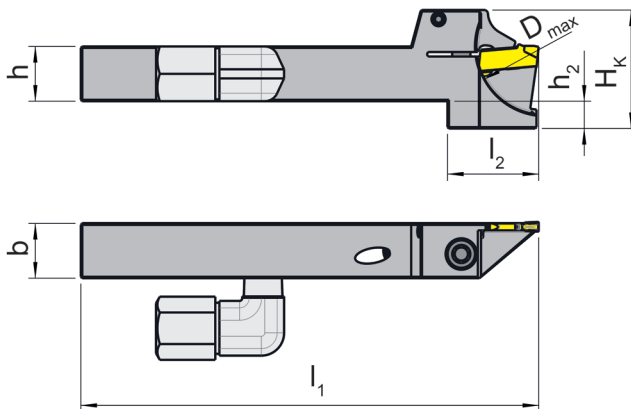

R = rechts wie gezeichnet
R = right hand version shown

L = links spiegelbildlich
L = left hand version

mit innerer
Kühlmittelzufuhr
with through coolant supply

Bestellnummer Part number	h	b	l ₁	l ₂	H _k	h ₂	D _{max}	Größe Size
910.L.1012.02.2IK	10	12	100	20	24	6	20	02
910.R.1012.02.2IK	10	12	100	20	24	6	20	02
910.L.1212.02.2IK	12	12	100	20	26	6	26	02
910.R.1212.02.2IK	12	12	100	20	26	6	26	02
910.L.1616.02.2IK	16	16	100	25	34	10	42	02
910.R.1616.02.2IK	16	16	100	25	34	10	42	02
910.L.1212.03.2IK	12	12	100	20	26	6	26	03
910.R.1212.03.2IK	12	12	100	20	26	6	26	03
910.L.1616.03.2IK	16	16	100	25	34	10	42	03
910.R.1616.03.2IK	16	16	100	25	34	10	42	03

Abmessungen in mm
Dimensions in mm

Weitere Abmessungen auf Anfrage
Further sizes upon request

Ersatzteile

Spare Parts

Klemmhalter Toolholder	Kühlmittelanschluss Coolant supply
910...	004.00.22

C

Einstechen und Abstechen

Grooving and Parting Off



Schneidplatte

Insert

S100

mit Spanformrinne
with chip former

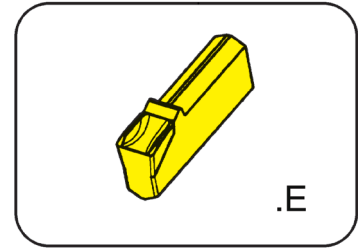

Stechbreite	Width of groove	2-3 mm
-------------	-----------------	--------

für Klemhalter
for Toolholder

Typ H100
Type

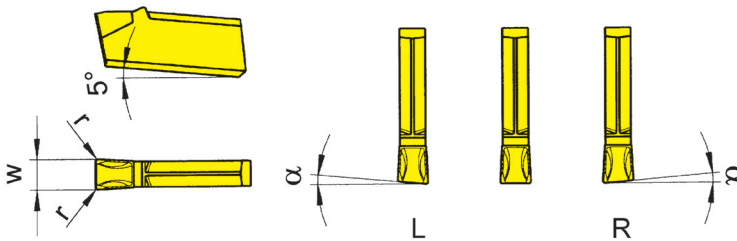

R = Rechtsausführung
R = right hand version

L = Linksausführung
L = left hand version

Bestellnummer Part number	w	r	α	Größe Size	ALX2	ALX3	AS63	AS66	TC92	TC93	TF42	TF43	TF45	TF46	Ti22
S100.0200.E2	2,0	0,2	0°	01		▲			Δ	Δ		▲	▲	▲	▲
R/LS100.0520.E2	2,0	0,2	5°	01					Δ/Δ	Δ/Δ		▲/Δ	▲/▲	Δ/Δ	Δ/Δ
S100.0250.E2	2,5	0,2	0°	02					Δ	Δ		▲	▲	▲	▲
R/LS100.0525.E2	2,5	0,2	5°	02					Δ/Δ	▲/Δ		▲/Δ	▲/Δ	Δ/Δ	Δ/Δ
S100.0300.E2	3,0	0,2	0°	03	▲	▲	▲	▲	▲	▲	▲	▲	▲	▲	▲
R/LS100.0530.E2	3,0	0,2	5°	03		▲/▲			Δ/▲	Δ/Δ	▲/Δ	▲/▲	▲/▲	▲/▲	▲/Δ
▲ ab Lager / on stock Δ 4 Wochen / 4 weeks x auf Anfrage / upon request					P	●	●	●	●	●	●	●	●	●	●
● empfohlen / recommended					M	-	-	o	-	-	-	-	o	-	-
o bedingt einsetzbar / alternative recommendation					K	-	-	-	-	-	-	-	-	-	-
- nicht geeignet / not suitable					N	-	-	-	-	-	-	-	-	-	-
■ unbeschichtete HM-Sorten / uncoated grades					S	-	-	o	-	-	-	-	-	o	-
■ beschichtete HM-Sorten / coated grades					H	-	-	-	-	-	-	-	-	-	-
■ bestückt/Cermet / brazed/Cermet															

Abmessungen in mm
Dimensions in mm
Ausführung R oder L angeben
State R or L version

HM-Sorten
Carbide grades

Einstecken und Abstechen

Grooving and Parting Off



Schneidplatte

Insert

S100

mit Spanformrinne
with chip former

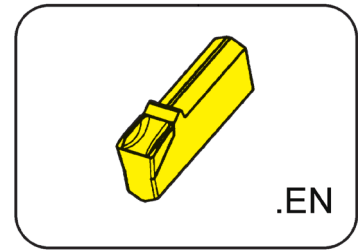

Stechbreite	Width of groove	2-3 mm
-------------	-----------------	--------

für Klemmhalter
for Toolholder

Typ H100
Type

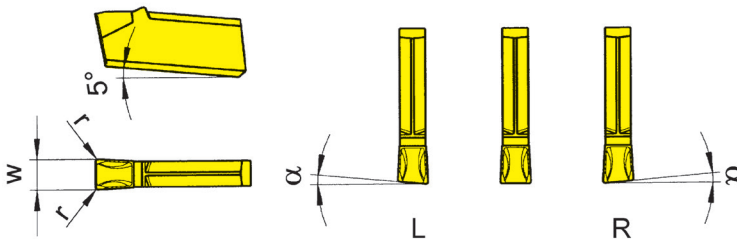

R = Rechtsausführung
R = right hand version

L = Linksausführung
L = left hand version

Bestellnummer Part number	w	r	α	Größe Size	ALX3	ALX5	AS62	AS63	AS66	AS6G	TF45	TH35
S100.0200.EN2	2,0	0,2	0°	01	▲	Δ				▲		Δ
S100.0220.EN2	2,2	0,2	0°	01	▲					▲		
S100.0250.EN2	2,5	0,2	0°	02	▲					▲		
S100.0300.EN2	3,0	0,2	0°	03	▲	Δ		▲	▲	▲	Δ	
RS100.0530.EN2	3,0	0,2	5°	03			▲		▲			
P	•	•	•	•	•	•	•	•	•	•	•	•
M	-	•	-	-	o	•	•	•	•	•	•	•
K	-	•	-	-	•	•	•	•	•	•	•	•
N	-	•	-	-	•	•	•	•	•	•	•	•
S	-	•	-	-	o	•	•	•	•	•	•	•
H	-	-	-	-	-	-	-	-	-	-	-	-

- ▲ ab Lager / on stock Δ 4 Wochen / 4 weeks x auf Anfrage / upon request
- empfohlen / recommended
- o bedingt einsetzbar / alternative recommendation
- nicht geeignet / not suitable
- unbeschichtete HM-Sorten / uncoated grades
- beschichtete HM-Sorten / coated grades
- bestückt/Cermet / brazed/Cermet

Abmessungen in mm
Dimensions in mm
Ausführung R oder L angeben
State R or L version

HM-Sorten
Carbide grades



Einstecken und Abstechen

Grooving and Parting Off



Schneidplatte

Insert

S100

mit Spanformung
with chip forming

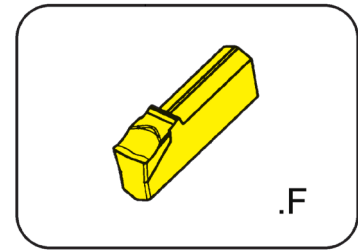

Stechbreite	Width of groove	2-3 mm
-------------	-----------------	--------

für Klemmhalter
for Toolholder

Typ H100
Type

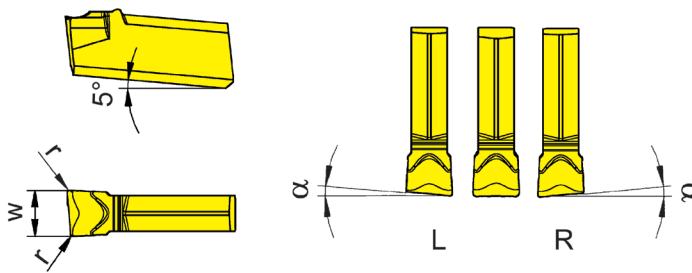

R = rechts wie gezeichnet
R = right hand version shown

L = links spiegelbildlich
L = left hand version

Bestellnummer Part number	w	r	α	Größe Size	TC92	TC93	TF42	TF43	TF45	TF46	T122
S100.0200.F2	2,0	0,2	0°	01	▲	△		▲	▲	▲	▲
R/LS100.0520.F2	2,0	0,2	5°	01	△/△	△/△		△/△	▲/▲	▲/△	△/△
S100.0250.F2	2,5	0,2	0°	02	△	△		△	▲	△	▲
R/LS100.0525.F2	2,5	0,2	5°	02	△/△	△/△		△/△	▲/▲	△/△	△/△
S100.0300.F2	3,0	0,2	0°	03	△	▲	△	▲	▲	▲	▲
R/LS100.0530.F2	3,0	0,2	5°	03	△/△	△/△		▲/▲	▲/▲	▲/▲	△/▲

▲ ab Lager / on stock △ 4 Wochen / 4 weeks x auf Anfrage / upon request

● empfohlen / recommended

o bedingt einsetzbar / alternative recommendation

- nicht geeignet / not suitable

□ unbeschichtete HM-Sorten / uncoated grades

■ beschichtete HM-Sorten / coated grades

■ bestückt/Cermet / brazed/Cermet

Abmessungen in mm

Dimensions in mm

Ausführung R oder L angeben

State R or L version

P	●	●	●	●	●	●	●	●	●	●	●
M	-	-	-	-	●	o	-	-	-	-	-
K	-	-	-	-	-	-	-	-	●	●	-
N	-	-	-	-	-	-	-	-	●	●	-
S	-	-	-	-	-	-	-	-	●	o	-
H	-	-	-	-	-	-	-	-	-	-	-

HM-Sorten
Carbide grades

Einstechen und Abstechen

Grooving and Parting Off



Schneidplatte

Insert

S100

mit Spanformung
with chip forming

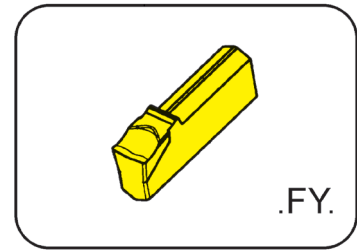

Stechbreite	Width of groove	2-3 mm
-------------	-----------------	--------

präzisionsgesintert
precision sintered

für Klemmhalter
for Toolholder

Typ H100
Type

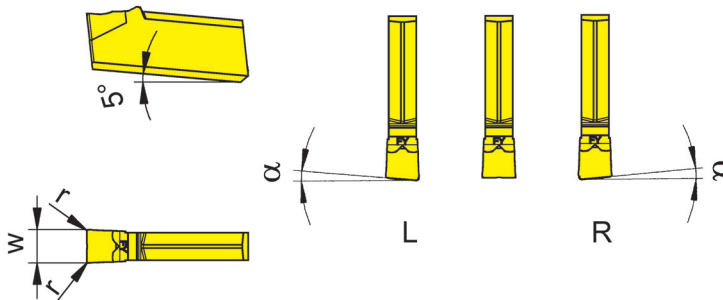

R = Rechtsausführung
R = right hand version

L = Linksausführung
L = left hand version

Bestellnummer Part number	w	r	α	Größe Size	AS45	HP65	IG35	PH35	TI25	
S100.0200.FY2	2,0	0,2	0°	01	▲	▲	▲	▲	▲	
R/LS100.1520.FY0	2,0	-	15°	01	▲/▲		▲/▲			
S100.0220.FY2	2,2	0,2	0°	01			▲		▲	
S100.0250.FY2	2,5	0,2	0°	02	▲	▲	▲		▲	
S100.0300.FY2	3,0	0,2	0°	03	▲	▲	▲	▲	▲	
R/LS100.1530.FY0	3,0	-	15°	03	▲/▲		▲/▲			
▲ ab Lager / on stock Δ 4 Wochen / 4 weeks x auf Anfrage / upon request					P	●	●	-	○	●
● empfohlen / recommended					M	●	●	●	○	●
○ bedingt einsetzbar / alternative recommendation					K	●	●	-	●	●
- nicht geeignet / not suitable					N	○	○	-	-	●
■ unbeschichtete HM-Sorten / uncoated grades					S	●	●	●	-	●
■ beschichtete HM-Sorten / coated grades					H	-	-	-	-	-
■ bestückt/Cermet / brazed/Cermet										

Abmessungen in mm
Dimensions in mm

Schneidplatten sind in **rechten und linken** Klemmhaltern verwendbar.
Indexable inserts can be used in **right and left** hand toolholders.

HM-Sorten
Carbide grades



Einstechen und Abstechen

Grooving and Parting Off



Schneidplatte

Insert

S100

mit Spanformung
with chip forming

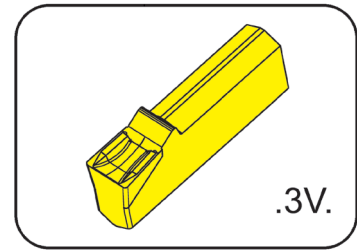

Stechbreite	Width of groove	2-3 mm
-------------	-----------------	--------

für Klemmhalter
for Toolholder

Typ H100
Type

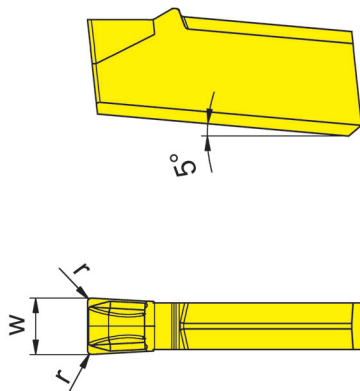

C

Bestellnummer Part number	w	r	Größe Size	AS45	HP35	HP65	IG35	PH35	
S100.0200.3V2	2,0	0,2	01	▲	△	▲	▲	▲	
S100.0250.3V2	2,5	0,2	02	▲		▲	▲		
S100.0300.3V2	3,0	0,2	03	▲		▲	▲	▲	
▲ ab Lager / on stock △ 4 Wochen / 4 weeks x auf Anfrage / upon request				P	●	○	●	-	○
● empfohlen / recommended				M	●	●	●	●	○
○ bedingt einsetzbar / alternative recommendation				K	●	○	●	-	●
- nicht geeignet / not suitable				N	○	-	○	-	-
■ unbeschichtete HM-Sorten / uncoated grades				S	●	○	●	●	-
■ beschichtete HM-Sorten / coated grades				H	-	-	-	-	-
■ bestückt/Cermet / brazed/Cermet									

Abmessungen in mm
Dimensions in mm

HM-Sorten
Carbide grades

Einstecken und Abstecken

Grooving and Parting Off



Schneidplatte

Insert

S100

mit Spanformung
with chip forming

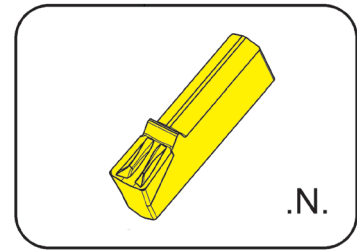

Stechbreite	Width of groove	3 mm
-------------	-----------------	------

für Klemmhalter
for Toolholder

Typ H100
Type

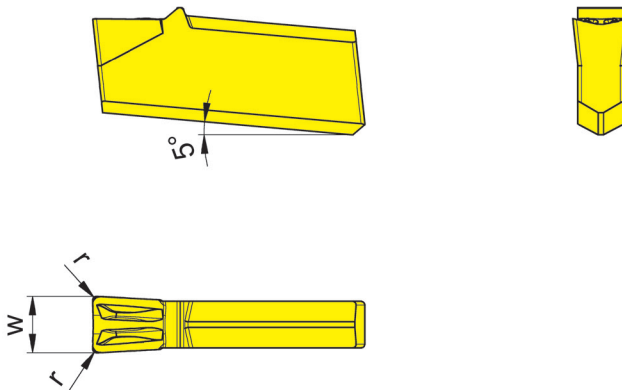

Bestellnummer Part number	w	r	Größe Size	AS45	HP65
S100.0300.N2	3	0,2	03	▲	▲

▲ ab Lager / on stock Δ 4 Wochen / 4 weeks x auf Anfrage / upon request

● empfohlen / recommended

o bedingt einsetzbar / alternative recommendation

- nicht geeignet / not suitable

■ unbeschichtete HM-Sorten / uncoated grades

■ beschichtete HM-Sorten / coated grades

■ bestückt/Cermet / brazed/Cermet

Abmessungen in mm

Dimensions in mm

P	●	●
M	●	●
K	●	●
N	o	o
S	●	●
H	-	-

HM-Sorten
Carbide grades

Einstechen und Abstechen

Grooving and Parting Off



Schneidplatte

Insert

S100

mit Spanformung
with chip forming

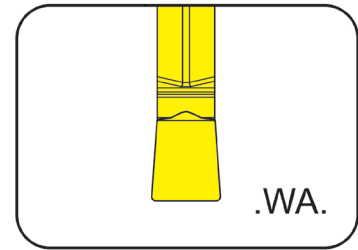

Stechbreite	Width of groove	2-3 mm
-------------	-----------------	--------

präzisionsgeschliffen und poliert
precision ground and polished

für Klemmhalter
for Toolholder

Typ H100
Type

C

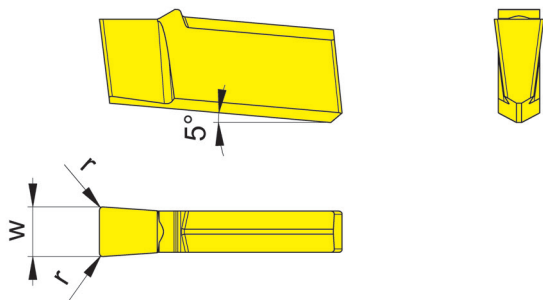

für Aluminium
for Aluminium

Bestellnummer Part number	w	r	Größe Size	K10	DD26
S100.0200.WA2	2	0,2	02	▲	▲
S100.0300.WA2	3	0,2	03	▲	▲
				P ●	-
				M ○	-
				K ●	-
				N ●	●
				S ○	○
				H -	-

- ▲ ab Lager / on stock Δ 4 Wochen / 4 weeks x auf Anfrage / upon request
- empfohlen / recommended
- bedingt einsetzbar / alternative recommendation
- nicht geeignet / not suitable
- unbeschichtete HM-Sorten / uncoated grades
- beschichtete HM-Sorten / coated grades
- bestückt/Cermet / brazed/Cermet

Abmessungen in mm
Dimensions in mm

Schneidplatten sind in **rechten und linken** Klemmhaltern verwendbar.
Indexable inserts can be used in **right and left** hand toolholders.

HM-Sorten
Carbide grades

Einstechen und Abstechen

Grooving and Parting Off



Klemmhalter

Toolholder

H101

mit Schraubklemmung
with screwed clamping

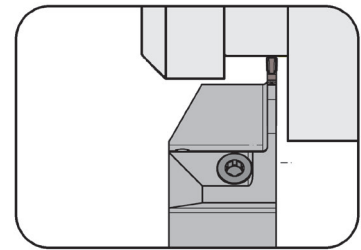

Stechtiefe bis Stechbreite	Depth of groove up to Width of groove	13 mm 1,2-1,6 mm
-------------------------------	--	---------------------

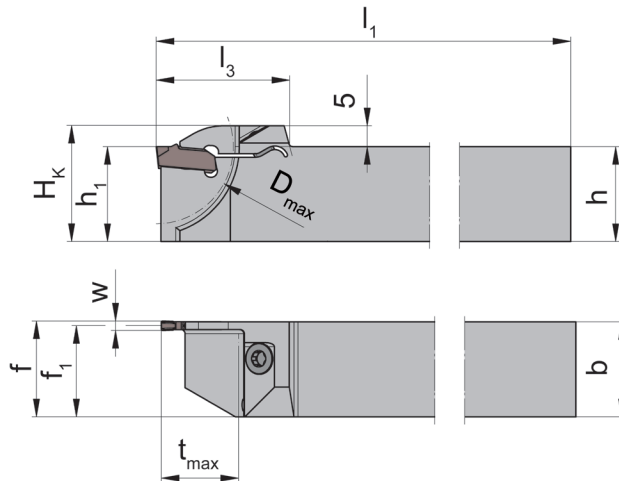

für Schneidplatte
for Insert

Typ S101
Type



Bestellnummer Part number	h	b	l ₁	l ₃	h ₁	f ₁	f	t _{max}	H _k	D _{max}	Größe Size
R/LH101.1010.1.12	10	10	125	22,5	10	9,53	f ₁ +w/2	13	13,5	26	12
R/LH101.1212.1.12	12	12	125	22,5	12	11,53	f ₁ +w/2	13	15,5	26	12
R/LH101.1616.1.12	16	16	125	22,5	16	15,53	f ₁ +w/2	13	19,5	26	12
R/LH101.1010.1.16	10	10	125	22,5	10	9,35	f ₁ +w/2	13	13,5	26	16
R/LH101.1212.1.16	12	12	125	22,5	12	11,35	f ₁ +w/2	13	15,5	26	16
R/LH101.1616.1.16	16	16	125	22,5	16	15,35	f ₁ +w/2	13	19,5	26	16

Ausführung R oder L angeben
State R or L version

w siehe Schneidplatten
w see inserts

Abmessungen in mm
Dimensions in mm

Weitere Abmessungen auf Anfrage
Further sizes upon request

Das Anzugsdrehmoment der Schrauben finden Sie in den Technischen Hinweisen.
For torque specification of the screw, please see Technical Instructions.

Ersatzteile

Spare Parts

Klemmhalter Toolholder	Spannschraube Clamping Screw	TORX PLUS®-Schlüssel TORX PLUS® Wrench
R/LH101...	3.5.12T10EP	T10PL

Einstecken und Abstechen

Grooving and Parting Off



Schneidplatte

Insert

S101

mit Spanformung
with chip forming

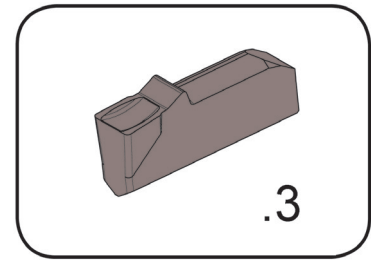

Stechbreite	Width of groove	1,2-1,6 mm
-------------	-----------------	------------

für Klemmhalter
for Toolholder

Typ H101
Type

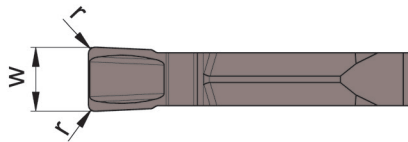
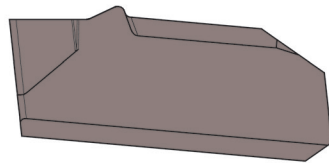

C

Bestellnummer Part number	w	r	Größe Size	AS45	IG35
S101.0120.315	1,2	0,15	12	▲	▲
S101.0160.315	1,6	0,15	16	▲	▲

▲ ab Lager / on stock Δ 4 Wochen / 4 weeks x auf Anfrage / upon request

● empfohlen / recommended

o bedingt einsetzbar / alternative recommendation

- nicht geeignet / not suitable

■ unbeschichtete HM-Sorten / uncoated grades

■ beschichtete HM-Sorten / coated grades

■ bestückt/Cermet / brazed/Cermet

Abmessungen in mm

Dimensions in mm

	AS45	IG35
P	●	-
M	●	●
K	●	-
N	o	-
S	●	●
H	-	-

HM-Sorten
Carbide grades

262

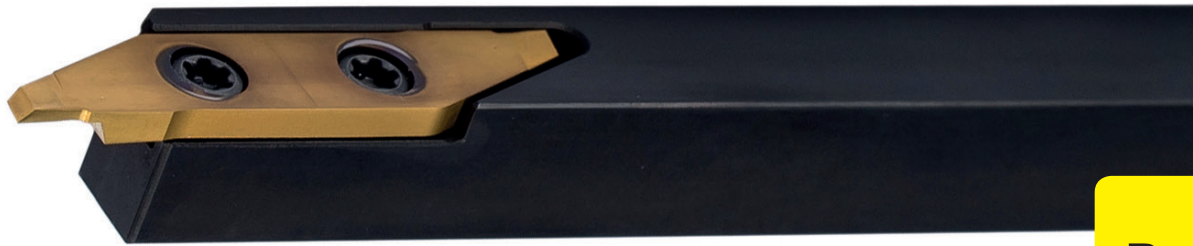

D

**Klemmhalter mit
Schneidplatten**

Stechbreite 0,5 - 2 mm

**Toolholder with
Inserts**

Width of groove 0,5 - 2 mm

Einstecken (außen)

Grooving (external)

Klemmhalter
Toolholder
H262

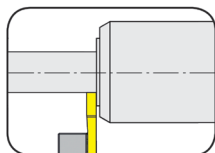

Seite/Page
D3

Wendeschneidplatte
Indexable insert
S262

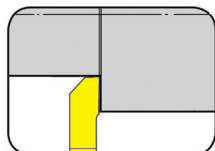

Seite/Page
D4

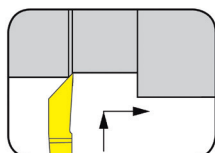

Seite/Page
D5

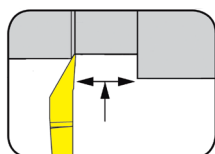

Seite/Page
D6

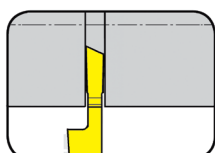

Seite/Page
D7

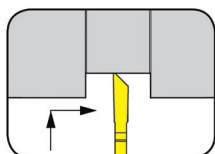

Seite/Page
D8-D9

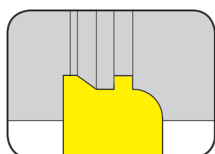

Seite/Page
D10

D

Einstecken und Drehen

Grooving and Turning



Klemmhalter

Toolholder

H262

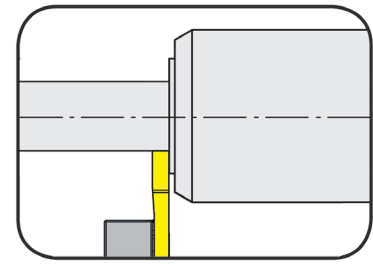

Stechtiefe bis
Stechbreite bis

Depth of groove up to
Width of groove up to

7,5 mm
0,025-6 mm

für Wendeschneidplatte
for Indexable insert

Typ LS262
Type

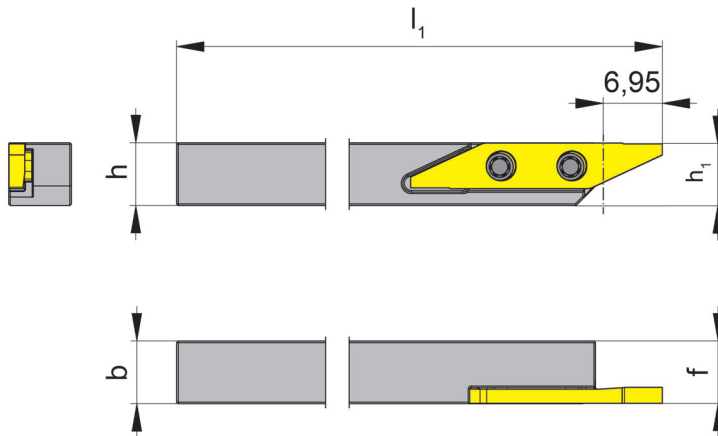

L = links wie gezeichnet
L = left hand version shown

Bestellnummer Part number	h	b	l_1	h_1	f	t_{max}	Größe Size
LH262.0606.04	6	6	100	5,83	5,95	7,5	04
LH262.0707.04	7	7	100	6,83	6,95	7,5	04
LH262.0808.04	8	8	100	7,83	7,95	7,5	04
LH262.0808.2.04	8	8	150	7,83	7,95	7,5	04
LH262.1010.04	10	10	100	9,83	9,95	7,5	04

Weitere Abmessungen auf Anfrage
Further sizes upon request

Abmessungen in mm
Dimensions in mm

Das Anzugsdrehmoment der Schrauben finden Sie in den Technischen Hinweisen.
For torque specification of the screw, please see Technical Instructions.

Ersatzteile

Spare Parts

Klemmhalter Toolholder	Spannschraube Clamping Screw	TORX PLUS®-Schlüssel TORX PLUS® Wrench
LH262...	030.2557.T8P	T8PL

D

Einstechen und Längsdrehen

Grooving and Side Turning



Wendeschneidplatte

Indexable insert

S262

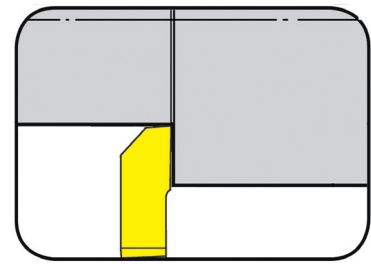

Stechbreite	Width of groove	0,05-2 mm
-------------	-----------------	-----------

für Klemhalter
for Toolholder

Typ LH262
Type

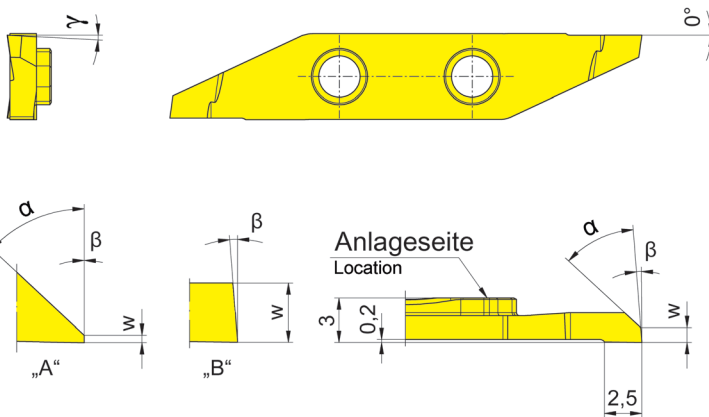

L = links wie gezeichnet
L = left hand version shown

Bestellnummer Part number	w	γ	α	Form Form	β	EG35
LS262.0547.04	0,05	0°	47°	A	0°	▲
LS262.2047.03	2,00	3°	0°	B	4°	Δ

- ▲ ab Lager / on stock Δ 4 Wochen / 4 weeks x auf Anfrage / upon request
- empfohlen / recommended
- o bedingt einsetzbar / alternative recommendation
- nicht geeignet / not suitable
- unbeschichtete HM-Sorten / uncoated grades
- beschichtete HM-Sorten / coated grades
- bestückt/Cermet / brazed/Cermet

Abmessungen in mm
Dimensions in mm

HM-Sorten
Carbide grades

P	●
M	●
K	○
N	-
S	-
H	-

D

Kopierdrehen (Schlichten)

Copy Turning (Finishing)



Wendeschneidplatte

S262

Indexable insert

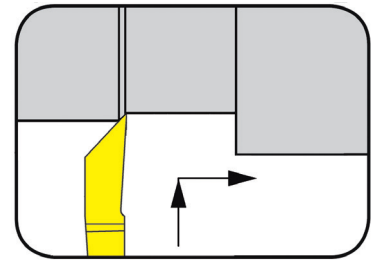

Schneidbreite Schnitttiefe bis	Width of groove Depth of cut up to	0,025 mm 1,8 mm
-----------------------------------	---------------------------------------	--------------------

für Klemhalter
for Toolholder

Typ LH262
Type

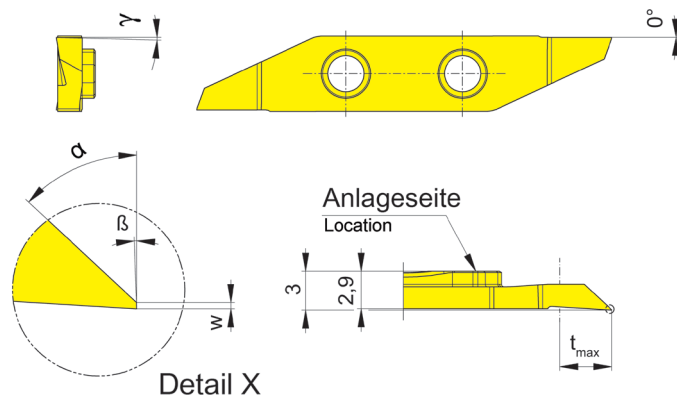

L = links wie gezeichnet
L = left hand version shown

Bestellnummer Part number	w	t _{max}	γ	α	β	EG35
LS262.0247.04	0,025	1,8	1,5°	47°	2°	▲

- ▲ ab Lager / on stock Δ 4 Wochen / 4 weeks x auf Anfrage / upon request
- empfohlen / recommended
- o bedingt einsetzbar / alternative recommendation
- nicht geeignet / not suitable
- unbeschichtete HM-Sorten / uncoated grades
- beschichtete HM-Sorten / coated grades
- bestückt/Cermet / brazed/Cermet

Abmessungen in mm
Dimensions in mm

HM-Sorten
Carbide grades

P	●
M	●
K	o
N	-
S	-
H	-



Wendeschneidplatte

Indexable insert

S262

Schneidbreite Schnitttiefe bis	Width of groove Depth of cut up to	0,03-0,105 mm 3 mm
-----------------------------------	---------------------------------------	-----------------------

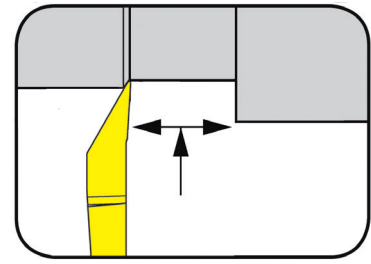

für Klemhalter
for Toolholder

Typ LH262
Type

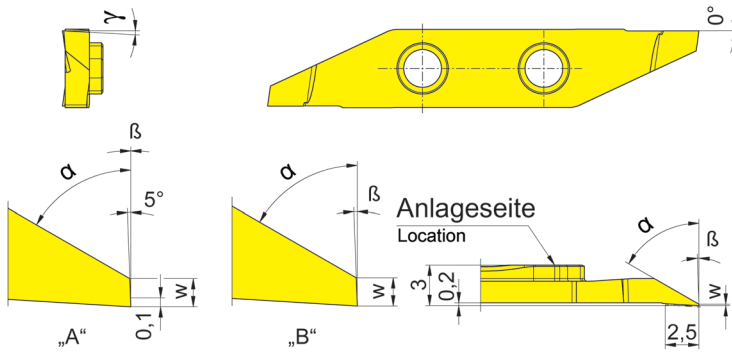

L = links wie gezeichnet
L = left hand version shown

Bestellnummer Part number	w	t _{max}	γ	α	Form Form	β	EG35
LS262.0147.04	0,030	1,8	0°	47°	A	0°	▲
LS262.0160.03	0,105	3,0	3°	60°	B	2°	▲

- ▲ ab Lager / on stock Δ 4 Wochen / 4 weeks x auf Anfrage / upon request
- empfohlen / recommended
- o bedingt einsetzbar / alternative recommendation
- nicht geeignet / not suitable
- unbeschichtete HM-Sorten / uncoated grades
- beschichtete HM-Sorten / coated grades
- bestückt/Cermet / brazed/Cermet

Abmessungen in mm
Dimensions in mm

P	●
M	●
K	○
N	-
S	-
H	-

HM-Sorten
Carbide grades

Abstechen

Parting Off



Wendeschneidplatte

Indexable insert

S262

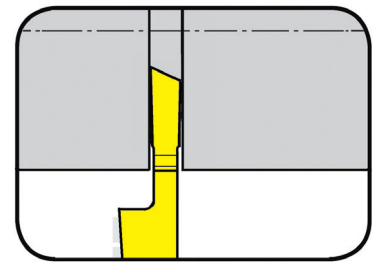

Schneidbreite Schnitttiefe bis	Width of groove Depth of cut up to	0,7-1 mm 5 mm
-----------------------------------	---------------------------------------	------------------

für Klemmhalter
for Toolholder

Typ LH262
Type

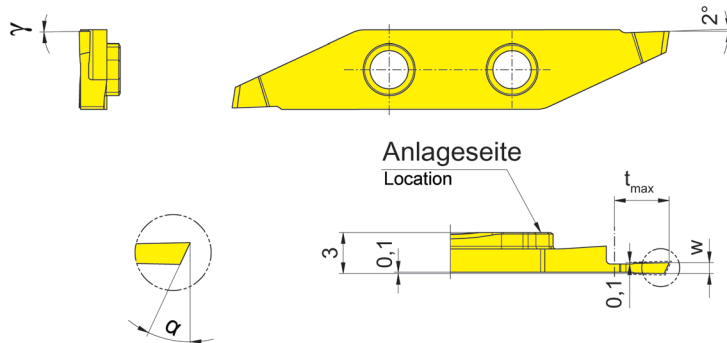

L = links wie gezeichnet
L = left hand version shown

Bestellnummer Part number	w	t _{max}	γ	α	EG35
LS262.2007.02	0,7	2	0°	20°	▲
LS262.2508.03	0,8	3	0°	25°	▲
LS262.2509.04	0,9	4	0°	25°	▲
LS262.2510.05	1,0	5	0°	25°	▲

▲ ab Lager / on stock Δ 4 Wochen / 4 weeks x auf Anfrage / upon request

● empfohlen / recommended

o bedingt einsetzbar / alternative recommendation

- nicht geeignet / not suitable

□ unbeschichtete HM-Sorten / uncoated grades

■ beschichtete HM-Sorten / coated grades

■ bestückt/Cermet / brazed/Cermet

Abmessungen in mm

Dimensions in mm

P	●
M	●
K	○
N	-
S	-
H	-

HM-Sorten
Carbide grades



Einstecken/Rückwärtsdrehen

Grooving/Backturning



Wendeschneidplatte

Indexable insert

S262

Schneidbreite Schnitttiefe bis	Width of groove Depth of cut up to	0,8-1,8 mm 6 mm
-----------------------------------	---------------------------------------	--------------------

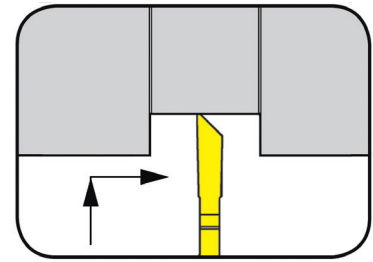

für Klemhalter
for Toolholder

Typ LH262
Type

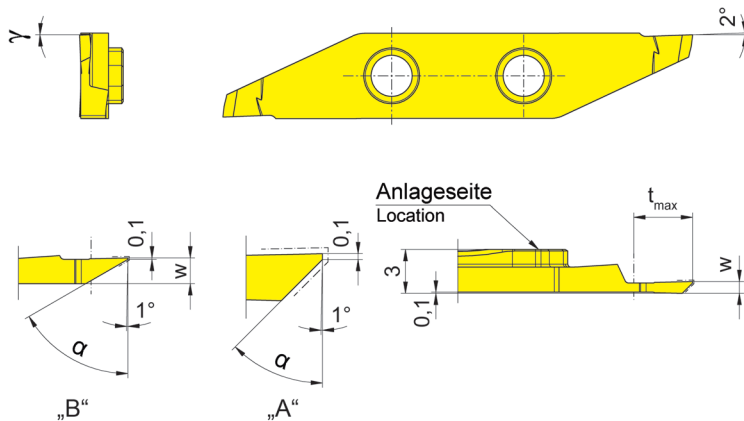

L = links wie gezeichnet
L = left hand version shown

Bestellnummer Part number	w	t _{max}	γ	α	Form Form	EG35
LS262.4508.04	0,8	2,0	0°	45°	A	▲
LS262.4509.04	0,9	4,0	0°	45°	A	▲
LS262.4510.06	1,0	6,0	0°	45°	A	▲
LS262.4512.06	1,2	6,0	0°	45°	A	▲
LS262.6015.02	1,8	2,5	0°	60°	B	▲
LS262.7010.02	1,2	2,5	0°	70°	B	▲

▲ ab Lager / on stock Δ 4 Wochen / 4 weeks x auf Anfrage / upon request

● empfohlen / recommended

o bedingt einsetzbar / alternative recommendation

- nicht geeignet / not suitable

■ unbeschichtete HM-Sorten / uncoated grades

■ beschichtete HM-Sorten / coated grades

■ bestückt/Cermet / brazed/Cermet

Abmessungen in mm

Dimensions in mm

P	●
M	●
K	○
N	-
S	-
H	-

HM-Sorten
Carbide grades

Einstecken/Rückwärtsdrehen

Grooving/Backturning



Wendeschneidplatte

Indexable insert

S262

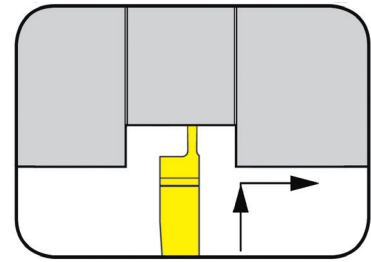

Schneidbreite Schnitttiefe bis	Width of groove Depth of cut up to	0,5-2 mm 3 mm
-----------------------------------	---------------------------------------	------------------

für Klemmhalter
for Toolholder

Typ LH262
Type

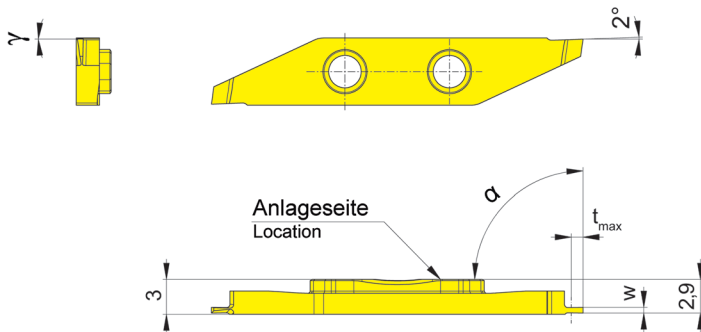

L = links wie gezeichnet
L = left hand version shown

Bestellnummer Part number	w	t _{max}	γ	α	EG35
LS262.0005.01	0,5	1	0°	90°	▲
LS262.0010.02	1,0	2	0°	90°	▲
LS262.0012.02	1,2	2	0°	90°	▲
LS262.0015.03	1,5	3	0°	90°	▲
LS262.0020.03	2,0	3	0°	90°	▲

▲ ab Lager / on stock Δ 4 Wochen / 4 weeks x auf Anfrage / upon request

● empfohlen / recommended

o bedingt einsetzbar / alternative recommendation

- nicht geeignet / not suitable

□ unbeschichtete HM-Sorten / uncoated grades

■ beschichtete HM-Sorten / coated grades

■ bestückt/Cermet / brazed/Cermet

Abmessungen in mm

Dimensions in mm

P	●
M	●
K	○
N	-
S	-
H	-

HM-Sorten
Carbide grades



Halbzeug

Semi-finished Insert



Wendeschneidplatte

Indexable insert

S262

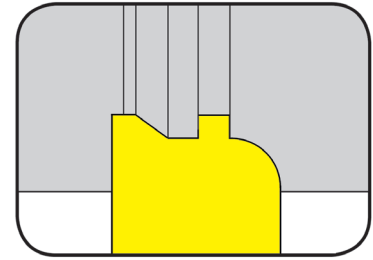

Schneidbreite Schnitttiefe bis	Width of groove Depth of cut up to	2 mm 7,5 mm
-----------------------------------	---------------------------------------	----------------

für Klemhalter
for Toolholder

Typ LH262
Type

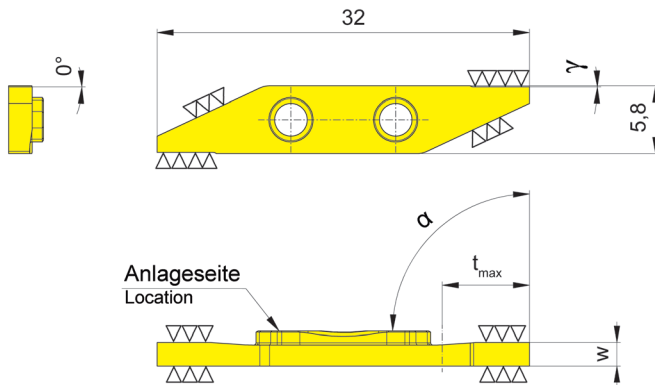

L = links wie gezeichnet
L = left hand version shown

Bestellnummer Part number	w	t _{max}	γ	α	MG12
LS262.8520.06	2	7,5	0°	90°	▲

▲ ab Lager / on stock Δ 4 Wochen / 4 weeks x auf Anfrage / upon request

● empfohlen / recommended

o bedingt einsetzbar / alternative recommendation

- nicht geeignet / not suitable

□ unbeschichtete HM-Sorten / uncoated grades

■ beschichtete HM-Sorten / coated grades

■ bestückt/Cermet / brazed/Cermet

Abmessungen in mm

Dimensions in mm

P	o
M	-
K	-
N	-
S	-
H	-

HM-Sorten
Carbide grades

264



E

**Klemmhalter mit
Schneidplatten**

Stechbreite 1,5 - 3 mm

**Toolholder with
Inserts**

Width of groove 1,5 - 3 mm

Einstecken und Längsdrehen (außen)

Grooving and Side Turning (external)

Klemmhalter
Toolholder
H264

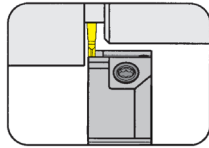

Seite/Page
E3-E6

Wendeschneidplatte
Indexable insert
264

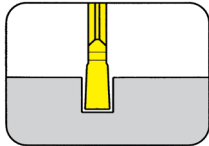

Seite/Page
E7, E9, E11

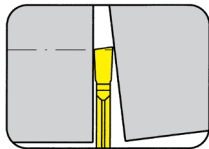

Seite/Page
E8, E10

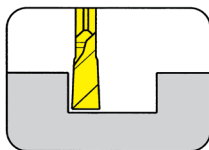

Seite/Page
E12-E13

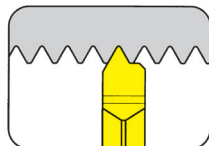

Seite/Page
E14

E

Einstechen und Abstechen

Grooving and Parting Off



Klemmhalter

Toolholder

H264

mit Schraubklemmung
with screwed clamping

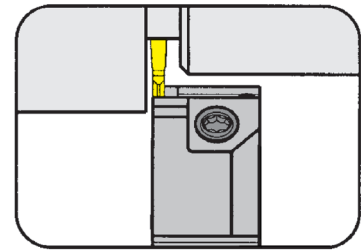

Stechtiefe bis Stechbreite	Depth of groove up to Width of groove	16 mm 1,5-2 mm
-------------------------------	--	-------------------

für Wendeschneidplatte
for Indexable insert

Typ 264
Type

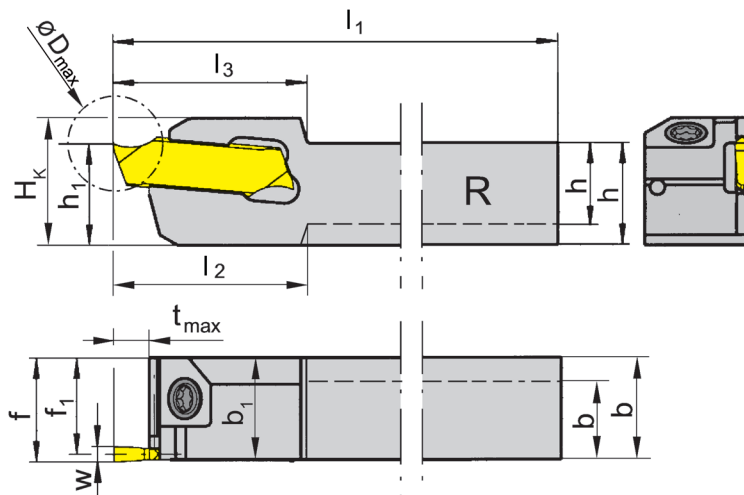

R = rechts wie gezeichnet
R = right hand version shown

L = links spiegelbildlich
L = left hand version

Bestellnummer Part number	h	b	l ₁	l ₂	l ₃	h ₁	b ₁	f ₁	f	t _{max}	D _{max}	H _k	Größe Size
R/LH264.0808.01	8	10	120	17,5	17,5	8	10	9,25	10	4	22	12,5	01
R/LH264.1010.01	10	10	120	-	17,5	10	-	9,25	10	4	22	12,5	01
R/LH264.1212.01	12	12	120	-	17,5	12	-	11,25	12	4	22	14,5	01
R/LH264.1616.01	16	16	120	-	17,5	16	-	15,25	16	4	32	18,5	01
R/LH264.1010.11	10	10	120	-	19,0	10	-	9,25	10	10	20	12,5	01
R/LH264.1212.11	12	12	120	-	19,0	12	-	11,25	12	10	20	14,5	01
R/LH264.1616.11	16	16	120	-	19,0	16	-	15,25	16	10	32	18,5	01
R/LH264.1212.21	12	12	120	-	22,0	12	-	11,25	12	13	26	15,5	01
R/LH264.1616.21	16	16	120	-	22,0	16	-	15,25	16	13	32	19,5	01
R/LH264.1010.02	10	10	120	-	17,5	10	-	9,00	10	4	32	12,5	02
R/LH264.1212.02	12	12	120	-	17,5	12	-	11,00	12	4	32	14,5	02
R/LH264.1616.02	16	16	120	-	17,5	16	-	15,00	16	4	32	18,5	02
R/LH264.1010.12	10	10	120	-	19,0	10	-	9,00	10	10	32	12,5	02
R/LH264.1212.12	12	12	120	-	19,0	12	-	11,00	12	10	32	14,5	02
R/LH264.1616.12	16	16	120	-	19,0	16	-	15,00	16	10	32	18,5	02
R/LH264.1212.22	12	12	120	-	25,0	12	-	11,00	12	16	32	14,5	02
R/LH264.1616.22	16	16	120	-	25,0	16	-	15,00	16	16	32	19,5	02

Ausführung R oder L angeben
State R or L version

w siehe Schneidplatten
w see inserts

Abmessungen in mm
Dimensions in mm

Weitere Abmessungen auf Anfrage
Further sizes upon request

Das Anzugsdrehmoment der Schrauben finden Sie in den Technischen Hinweisen.
For torque specification of the screw, please see Technical Instructions.

Ersatzteile

Spare Parts

Klemmhalter Toolholder	Spannschraube Clamping Screw	TORX PLUS®-Schlüssel TORX PLUS® Wrench
R/LH264...	3.5.12T10EP	T10PL

Einstecken und Abstechen

Grooving and Parting Off



Klemmhalter

Toolholder

H264

mit Schraubklemmung
with screwed clamping

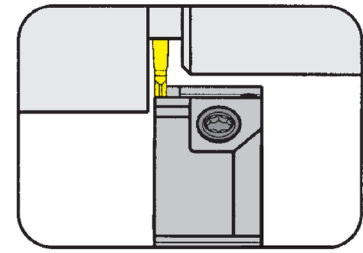

Stechtiefe bis Stechbreite	Depth of groove up to Width of groove	16 mm 2,5 mm
-------------------------------	--	-----------------

für Wendeschneidplatte
for Indexable insert

Typ 264
Type

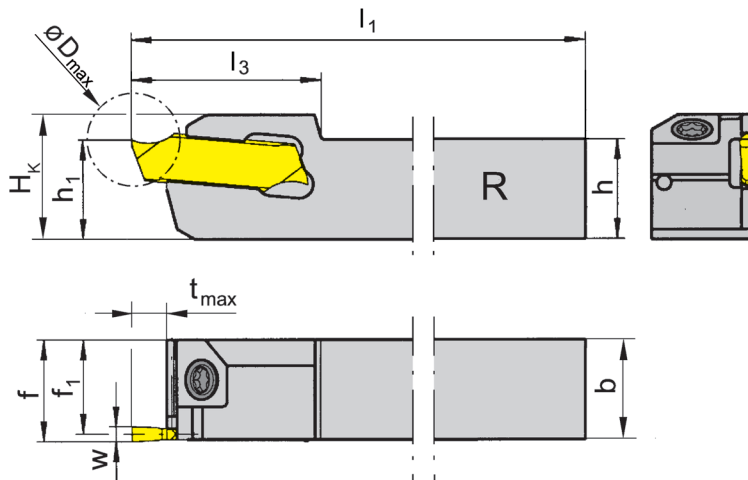

R = rechts wie gezeichnet
R = right hand version shown

L = links spiegelbildlich
L = left hand version

Bestellnummer Part number	h	b	l ₁	l ₃	h ₁	f ₁	f	t _{max}	D _{max}	H _k	Größe Size
R/LH264.1212.03	12	12	120	17,5	12	10,75	12	4	32	14,5	03
R/LH264.1616.03	16	16	120	17,5	16	14,75	16	4	32	18,5	03
R/LH264.1212.13	12	12	120	19,0	12	10,75	12	10	32	14,5	03
R/LH264.1616.13	16	16	120	19,0	16	14,75	16	10	32	18,5	03
R/LH264.1212.23	12	12	120	25,0	12	10,75	12	16	32	14,5	03
R/LH264.1616.23	16	16	120	25,0	16	14,75	16	16	32	18,5	03

Ausführung R oder L angeben
State R or L version

w siehe Schneidplatten
w see inserts

Abmessungen in mm
Dimensions in mm

Weitere Abmessungen auf Anfrage
Further sizes upon request

Das Anzugsdrehmoment der Schrauben finden Sie in den Technischen Hinweisen.
For torque specification of the screw, please see Technical Instructions.

Ersatzteile

Spare Parts

Klemmhalter Toolholder	Spannschraube Clamping Screw	TORX PLUS®-Schlüssel TORX PLUS® Wrench
R/LH264...	3.5.12T10EP	T10PL

Einstechen und Abstechen

Grooving and Parting Off



Klemmhalter

Toolholder

H264

mit Schraubklemmung
with screwed clamping

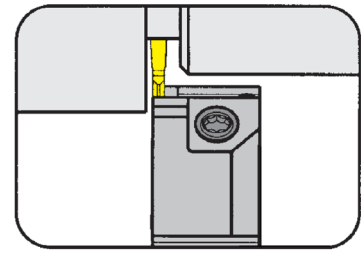

Stechtiefe bis Stechbreite	Depth of groove up to Width of groove	16 mm 3 mm
-------------------------------	--	---------------

für Wendeschneidplatte
for Indexable insert

Typ 264
Type

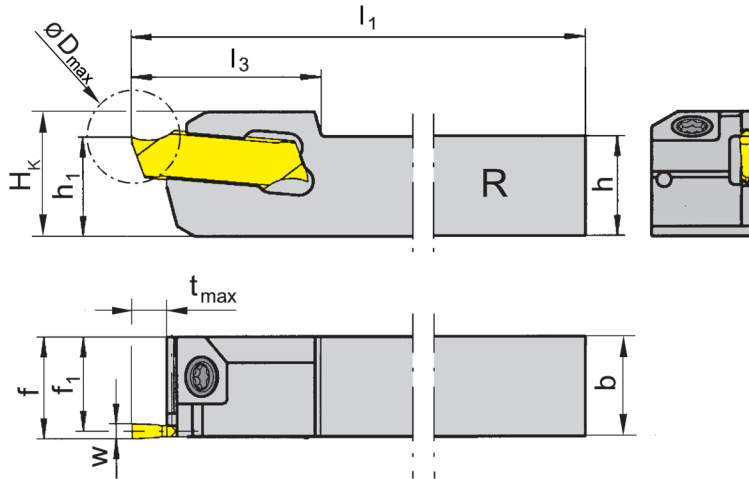

R = rechts wie gezeichnet
R = right hand version shown

L = links spiegelbildlich
L = left hand version

Bestellnummer Part number	h	b	l ₁	l ₃	h ₁	f ₁	f	t _{max}	D _{max}	H _K	Größe Size
R/LH264.1616.04	16	16	120	17,5	16	14,5	16	5	32	19	04
R/LH264.1212.04	12	12	120	17,5	12	10,5	12	5	32	15	04
R/LH264.1212.14	12	12	120	19,0	12	10,5	12	10	32	15	04
R/LH264.1616.14	16	16	120	19,0	16	14,5	16	10	32	19	04
R/LH264.1212.24	12	12	120	25,0	12	10,5	12	16	32	15	04
R/LH264.1616.24	16	16	120	25,0	16	14,5	16	16	32	19	04

Ausführung R oder L angeben
State R or L version

w siehe Schneidplatten
w see inserts

Abmessungen in mm
Dimensions in mm

Weitere Abmessungen auf Anfrage
Further sizes upon request

Das Anzugsdrehmoment der Schrauben finden Sie in den Technischen Hinweisen.
For torque specification of the screw, please see Technical Instructions.

Ersatzteile

Spare Parts

Klemmhalter Toolholder	Spannschraube Clamping Screw	TORX PLUS®-Schlüssel TORX PLUS® Wrench
R/LH264...	3.5.12T10EP	T10PL

Einstecken und Abstechen

Grooving and Parting Off



Klemmhalter

Toolholder

H264

mit Selbstklemmung
with self clamping

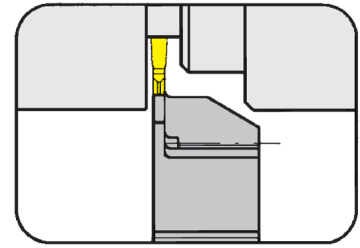

Stechtiefe bis Stechbreite	Depth of groove up to Width of groove	10 mm 1,5-3 mm
-------------------------------	--	-------------------

für Wendeschneidplatte
for Indexable insert

Typ 264
Type

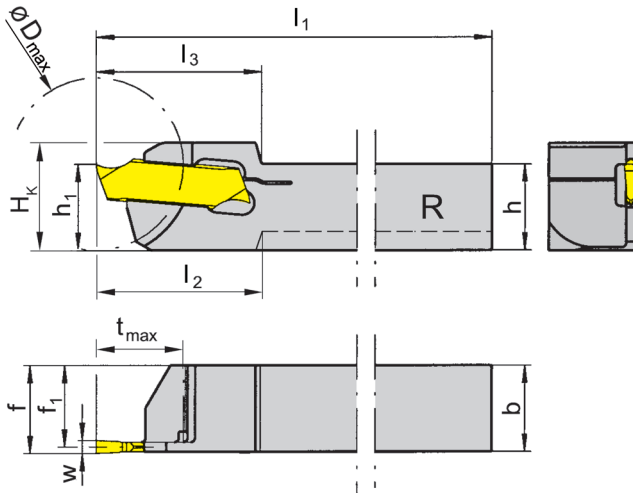

R = rechts wie gezeichnet
R = right hand version shown

L = links spiegelbildlich
L = left hand version

Bestellnummer Part number	h	b	l ₁	l ₂	l ₃	h ₁	f ₁	f	t _{max}	D _{max}	H _K	Größe Size
R/LH264.0808.51	8	8	120	18	18	10	7,25	8	7	20	12,5	01
R/LH264.1010.61	10	10	120	-	19	10	9,25	10	10	20	12,5	01
R/LH264.1010.62	10	10	120	-	19	10	9,00	10	10	20	12,5	02
R/LH264.1212.62	12	12	120	-	19	12	11,00	12	10	20	14,5	02
R/LH264.1212.63	12	12	120	-	19	12	10,75	12	10	32	14,5	03
R/LH264.1212.64	12	12	120	-	19	12	10,50	12	10	32	14,5	04

Ausführung R oder L angeben
State R or L version

w siehe Schneidplatten
w see inserts

Abmessungen in mm
Dimensions in mm

Weitere Abmessungen auf Anfrage
Further sizes upon request

Hinweis:

Der Schlüssel **P39L** gehört nicht zum Lieferumfang des Schneidträgers. Bitte separat bestellen!

Note:

Wrench **P39L** is not combined with toolholder - separate order required!

E

Einstechen und Abstechen

Grooving and Parting Off



Wendeschneidplatte

Indexable insert

264

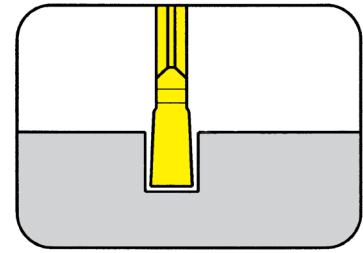

Stechtiefe bis Stechbreite	Depth of groove up to Width of groove	16 mm 1,5-3 mm
-------------------------------	--	-------------------

präzisionsgeschliffen
precision ground

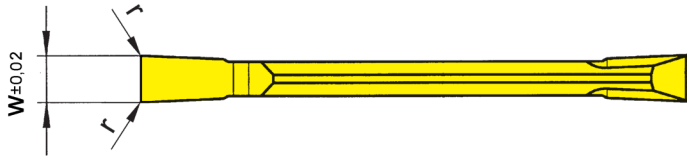
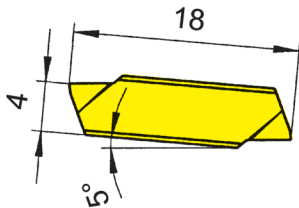

für Klemhalter
for Toolholder

Typ H264
Type

Wechselgenauigkeit
Länge ± 0,015 mm
Indexability length
± 0,015 mm

Bestellnummer Part number	w	r	Größe Size	MG12	TH35	TN35
264.0150.M0	1,5	0,05	01	▲	▲	▲
264.0200.M0	2,0	0,05	02	▲	▲	▲
264.0250.M0	2,5	0,10	03	△	△	▲
264.0300.M0	3,0	0,10	04	△	△	△
				P	o	•
				M	-	•
				K	-	•
				N	-	•
				S	-	•
				H	-	-

- ▲ ab Lager / on stock △ 4 Wochen / 4 weeks x auf Anfrage / upon request
- empfohlen / recommended
- o bedingt einsetzbar / alternative recommendation
- nicht geeignet / not suitable
- unbeschichtete HM-Sorten / uncoated grades
- beschichtete HM-Sorten / coated grades
- bestückt/Cermet / brazed/Cermet

Abmessungen in mm
Dimensions in mm

Wendeschneidplatten sind in rechten und linken Klemmhaltern verwendbar.
Indexable inserts can be used in right and left hand toolholders.

HM-Sorten
Carbide grades



Abstechen

Parting Off



Wendeschneidplatte

Indexable insert

264

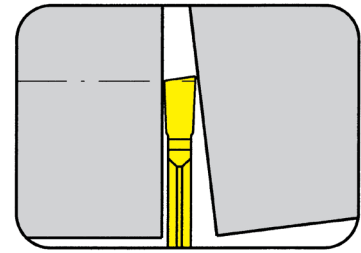

Stechtiefe bis Stechbreite	Depth of groove up to Width of groove	16 mm 1,5-3 mm
-------------------------------	--	-------------------

präzisionsgeschliffen
precision ground

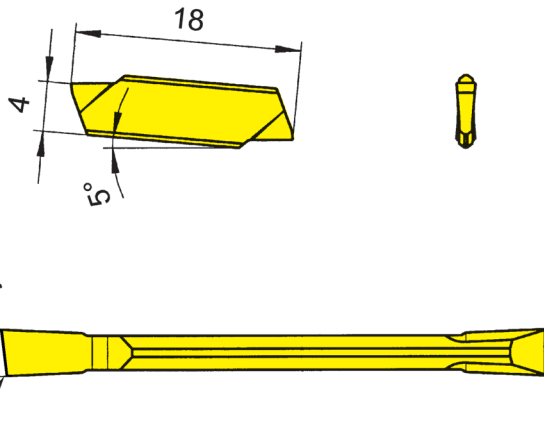

für Klemmhalter
for Toolholder

Typ H264
Type

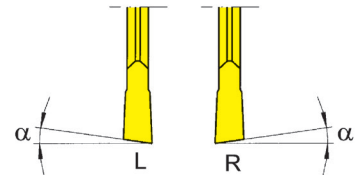

Wechselgenauigkeit
Länge ± 0,015 mm
Indexability length
± 0,015 mm

R = rechts wie gezeichnet
R = right hand version shown

L = links spiegelbildlich
L = left hand version

Bestellnummer Part number	w	r	α	Größe Size	MG12	TH35	TN35
R/L264.0815.M0	1,5	0,05	8°	01	Δ/▲	Δ/Δ	▲/▲
R/L264.1515.M0	1,5	0,05	15°	01	▲/▲	Δ/Δ	▲/Δ
R/L264.0820.M0	2,0	0,05	8°	02	Δ/Δ	Δ/Δ	▲/Δ
R/L264.1520.M0	2,0	0,05	15°	02	Δ/Δ	Δ/Δ	Δ/Δ
R/L264.0825.M0	2,5	0,10	8°	03	Δ/Δ	Δ/Δ	Δ/Δ
R/L264.1525.M0	2,5	0,10	15°	03	Δ/Δ	Δ/x	▲/Δ
R/L264.0830.M0	3,0	0,10	8°	04	Δ/Δ	Δ/Δ	Δ/Δ
R/L264.1530.M0	3,0	0,10	15°	04	Δ/Δ	Δ/Δ	▲/Δ

- ▲ ab Lager / on stock Δ 4 Wochen / 4 weeks x auf Anfrage / upon request
- empfohlen / recommended
- o bedingt einsetzbar / alternative recommendation
- nicht geeignet / not suitable
- unbeschichtete HM-Sorten / uncoated grades
- beschichtete HM-Sorten / coated grades
- bestückt/Cermet / brazed/Cermet

Abmessungen in mm
Dimensions in mm

Ausführung R oder L angeben
State R or L version

Wendeschneidplatten sind in rechten und linken Klemmhaltern verwendbar.
Indexable inserts can be used in right and left hand toolholders.

P	○	●	●
M	-	●	●
K	-	●	●
N	-	●	●
S	-	●	●
H	-	-	-

HM-Sorten
Carbide grades

E

Einstechen und Abstechen

Grooving and Parting Off



Wendeschneidplatte

Indexable insert

264

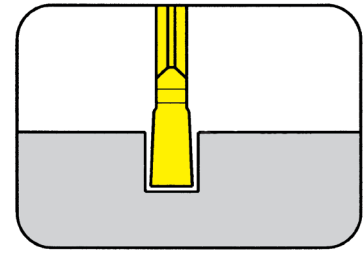

Stechtiefe bis Stechbreite	Depth of groove up to Width of groove	16 mm 1,5-3 mm
-------------------------------	--	-------------------

präzisionsgeschliffen
precision ground

für Klemmhalter
for Toolholder

Typ H264
Type

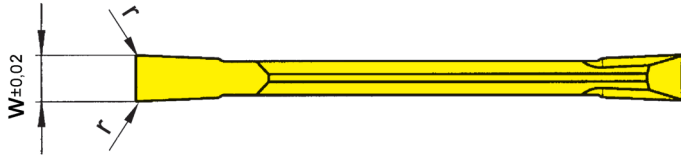
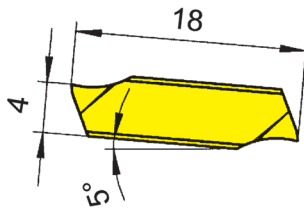

Wechselgenauigkeit
Länge ± 0,015 mm
Indexability length
± 0,015 mm



Bestellnummer Part number	w	r	Größe Size	MG12	TH35	TI25	TN35
				▲	▲	▲	▲
264.0150.10	1,5	0,05	01	▲	▲	▲	▲
264.0200.10	2,0	0,05	02	▲	▲	▲	▲
264.0250.10	2,5	0,10	03	▲	▲	▲	▲
264.0300.10	3,0	0,10	04	▲	▲	▲	▲
				P	o	•	•
				M	-	•	•
				K	-	•	•
				N	-	•	•
				S	-	•	•
				H	-	-	-

- ▲ ab Lager / on stock Δ 4 Wochen / 4 weeks x auf Anfrage / upon request
- empfohlen / recommended
- o bedingt einsetzbar / alternative recommendation
- nicht geeignet / not suitable
- unbeschichtete HM-Sorten / uncoated grades
- beschichtete HM-Sorten / coated grades
- bestückt/Cermet / brazed/Cermet

Abmessungen in mm
Dimensions in mm

Wendeschneidplatten sind in rechten und linken Klemmhaltern verwendbar.
Indexable inserts can be used in right and left hand toolholders.

HM-Sorten
Carbide grades

Abstechen

Parting Off



Wendeschneidplatte

Indexable insert

264

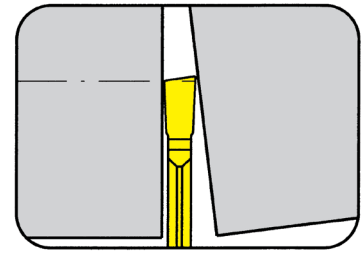

Stechtiefe bis Stechbreite	Depth of groove up to Width of groove	16 mm 1,5-3 mm
-------------------------------	--	-------------------

präzisionsgeschliffen
precision ground

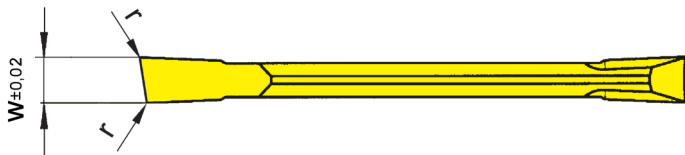
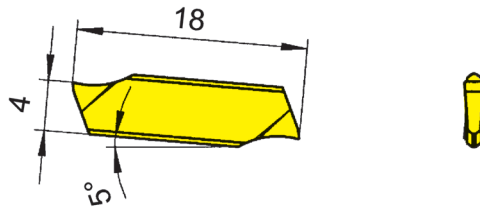

für Klemhalter
for Toolholder

Typ H264
Type

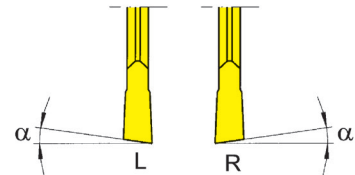

Wechselgenauigkeit
Länge ± 0,015 mm
Indexability length
± 0,015 mm

R = rechts wie gezeichnet
R = right hand version shown

L = links spiegelbildlich
L = left hand version

Bestellnummer Part number	w	r	α	Größe Size	HM-Sorten			
					MG12	TH35	TI25	TN35
R/L264.0815.10	1,5	0,05	8°	01	▲/▲	▲/▲	▲/▲	▲/▲
R/L264.1515.10	1,5	0,05	15°	01	▲/▲	▲/▲		▲/▲
R/L264.0820.10	2,0	0,05	8°	02	▲/▲	▲/▲		▲/▲
R/L264.1520.10	2,0	0,05	15°	02	▲/▲	▲/▲		▲/▲
R/L264.0825.10	2,5	0,10	8°	03	▲/▲	▲/▲		▲/▲
R/L264.1525.10	2,5	0,10	15°	03	▲/▲	▲/▲		▲/▲
R/L264.0830.10	3,0	0,10	8°	04	▲/▲	▲/▲		▲/▲
R/L264.1530.10	3,0	0,10	15°	04	▲/▲	▲/▲		▲/▲

- ▲ ab Lager / on stock Δ 4 Wochen / 4 weeks x auf Anfrage / upon request
- empfohlen / recommended
- o bedingt einsetzbar / alternative recommendation
- nicht geeignet / not suitable
- unbeschichtete HM-Sorten / uncoated grades
- beschichtete HM-Sorten / coated grades
- bestückt/Cermet / brazed/Cermet

P	○	●	●	●
M	-	●	●	●
K	-	●	●	●
N	-	●	●	●
S	-	●	●	●
H	-	-	-	-

HM-Sorten
Carbide grades

Abmessungen in mm
Dimensions in mm

Ausführung R oder L angeben
State R or L version

Wendeschneidplatten sind in rechten und linken Klemmhaltern verwendbar.
Indexable inserts can be used in right and left hand toolholders.

E

Einstechen und Abstechen

Grooving and Parting Off



Wendeschneidplatte

Indexable insert

264

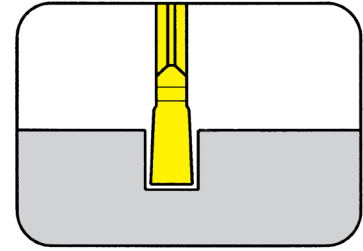

Stechtiefe bis Stechbreite	Depth of groove up to Width of groove	16 mm 1,5-3 mm
-------------------------------	--	-------------------

präzisionsgeschliffen
precision ground

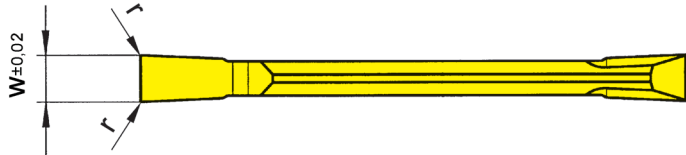
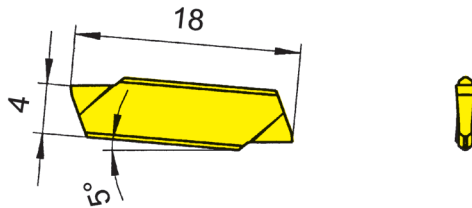

für Klemmhalter
for Toolholder

Typ H264
Type

Wechselgenauigkeit
Länge ± 0,015 mm
Indexability length
± 0,015 mm

Bestellnummer Part number	w	r	Größe Size	MG12	TH35	Ti25	TN35
264.0150.20	1,5	0,05	01	Δ	Δ	Δ	▲
264.0200.20	2,0	0,05	02	Δ	Δ		▲
264.0250.20	2,5	0,10	03	Δ	Δ		▲
264.0300.20	3,0	0,10	04	Δ	Δ		▲
				P	o	•	•
				M	-	•	•
				K	-	•	•
				N	-	•	•
				S	-	•	•
				H	-	-	-

- ▲ ab Lager / on stock Δ 4 Wochen / 4 weeks x auf Anfrage / upon request
- empfohlen / recommended
- o bedingt einsetzbar / alternative recommendation
- nicht geeignet / not suitable
- unbeschichtete HM-Sorten / uncoated grades
- beschichtete HM-Sorten / coated grades
- bestückt/Cermet / brazed/Cermet

Abmessungen in mm
Dimensions in mm

Wendeschneidplatten sind in rechten und linken Klemmhaltern verwendbar.
Indexable inserts can be used in right and left hand toolholders.

HM-Sorten
Carbide grades



Einstecken und Längsdrehen

Grooving and Side Turning



Wendeschneidplatte

Indexable insert

264

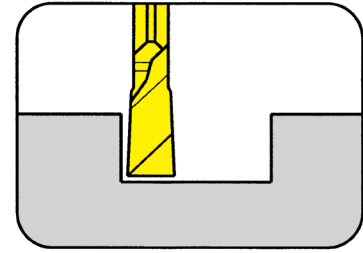

Stechtiefe bis Stechbreite	Depth of groove up to Width of groove	16 mm 1,5-3 mm
-------------------------------	--	-------------------

präzisionsgeschliffen
precision ground

für Klemhalter
for Toolholder

Typ H264
Type

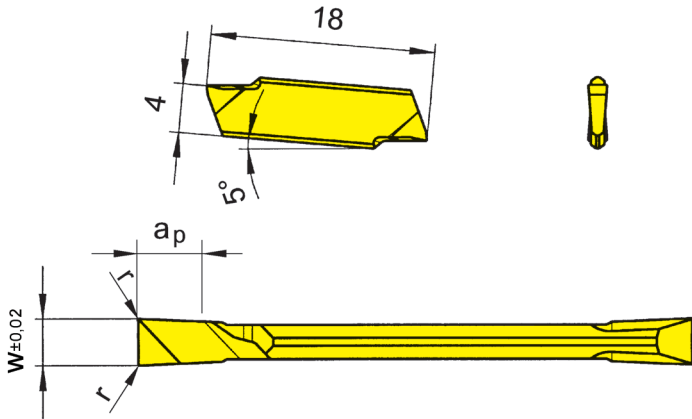

Wechselgenauigkeit
Länge ± 0,015 mm
Indexability length
± 0,015 mm

L = links wie gezeichnet
L = left hand version shown

R = rechts spiegelbildlich
R = right hand version

Bestellnummer Part number	w	r	Größe Size	MG12	TH35	TI25	TN35
R/L264.0150.P0	1,5	0,05	01	Δ/Δ	Δ/Δ	▲/Δ	▲/▲
R/L264.0200.P0	2,0	0,05	02	Δ/Δ	Δ/Δ	▲/▲	▲/Δ
R/L264.0200.P2	2,0	0,20	02				Δ/Δ
R/L264.0250.P0	2,5	0,10	03	Δ/Δ	Δ/Δ	Δ/Δ	▲/Δ
R/L264.0250.P2	2,5	0,20	03				Δ/Δ
R/L264.0300.P0	3,0	0,10	04	Δ/Δ	Δ/Δ	▲/Δ	▲/Δ
R/L264.0300.P2	3,0	0,20	04				Δ/Δ

- ▲ ab Lager / on stock Δ 4 Wochen / 4 weeks x auf Anfrage / upon request
- empfohlen / recommended
- o bedingt einsetzbar / alternative recommendation
- nicht geeignet / not suitable
- unbeschichtete HM-Sorten / uncoated grades
- beschichtete HM-Sorten / coated grades
- bestückt/Cermet / brazed/Cermet

P	o	●	●	●
M	-	●	●	●
K	-	●	●	●
N	-	●	●	●
S	-	●	●	●
H	-	-	-	-

Abmessungen in mm
Dimensions in mm

$a_p = 1,5 \times w$
 $a_p = 1,5 \times w$

HM-Sorten
Carbide grades

Ausführung R oder L angeben
State R or L version

Wendeschneidplatten sind in rechten und linken Klemmaltern verwendbar.
Indexable inserts can be used in right and left hand toolholders.

E

Einstecken und Längsdrehen

Grooving and Side Turning



Wendeschneidplatte

Indexable insert

264

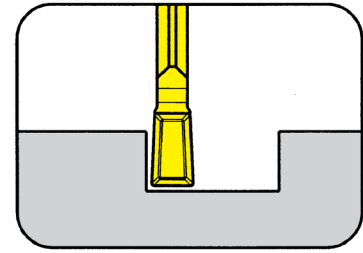

Stechtiefe bis Stechbreite	Depth of groove up to Width of groove	16 mm 1,5-3 mm
-------------------------------	--	-------------------

präzisionsgesintert
precision sintered

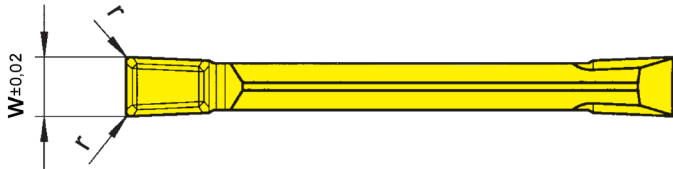
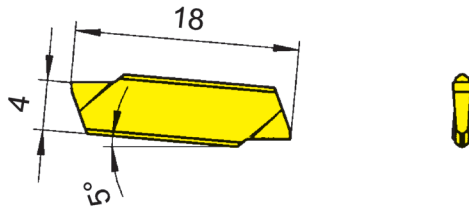

für Klemhalter
for Toolholder

Typ H264
Type

Wechselgenauigkeit
Länge ± 0,015 mm
Indexability length
± 0,015 mm



Bestellnummer Part number	w	r	Größe Size	MG12	TN35
S264.0150.D1	1,5	0,05	01	Δ	▲
S264.0200.D1	2,0	0,05	02	Δ	▲
S264.0250.D1	2,5	0,10	03	Δ	▲
S264.0300.D1	3,0	0,10	04	Δ	▲

▲ ab Lager / on stock Δ 4 Wochen / 4 weeks x auf Anfrage / upon request

● empfohlen / recommended

o bedingt einsetzbar / alternative recommendation

- nicht geeignet / not suitable

□ unbeschichtete HM-Sorten / uncoated grades

■ beschichtete HM-Sorten / coated grades

■ bestückt/Cermet / brazed/Cermet

Abmessungen in mm

Dimensions in mm

Wendeschneidplatten sind in rechten und linken Klemmhaltern verwendbar.

Indexable inserts can be used in right and left hand toolholders.

P	o	•
M	-	•
K	-	•
N	-	•
S	-	•
H	-	-

HM-Sorten
Carbide grades

Gewindedrehen (außen) Vollprofil

Threading (external) Full profile



Wendeschneidplatte

Indexable insert

264

Metrisches ISO-Gewinde
Metric ISO thread

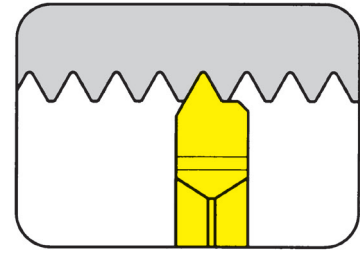

Steigung	Pitch	0,5-1,5 mm
----------	-------	------------

präzisionsgeschliffen
precision ground

für Klemhalter
for Toolholder

Typ H264
Type

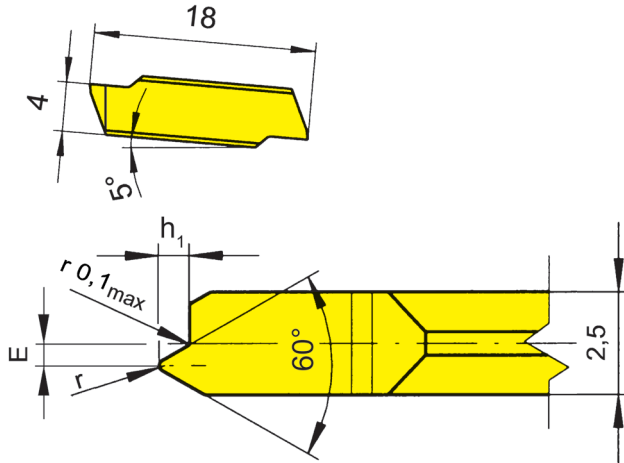

Wechselgenauigkeit
Länge ± 0,015 mm
Indexability length
± 0,015 mm

R = rechts wie gezeichnet
R = right hand version shown

L = links spiegelbildlich
L = left hand version

E

Bestellnummer Part number	P	E	r	h ₁	Größe Size	TF45
R/L264.0305.02	0,50	0,90	0,07	0,31	03	▲/Δ
R/L264.0306.02	0,60	0,90	0,09	0,37	03	Δ/Δ
R/L264.0307.02	0,70	0,80	0,10	0,43	03	▲/Δ
R/L264.0407.02	0,75	0,75	0,11	0,46	03	▲/Δ
R/L264.0408.02	0,80	0,70	0,12	0,49	03	▲/▲
R/L264.0610.02	1,00	0,60	0,12	0,61	03	▲/▲
R/L264.0712.02	1,25	0,50	0,15	0,77	03	▲/Δ
R/L264.0915.02	1,50	0,40	0,20	0,92	03	▲/Δ

▲ ab Lager / on stock Δ 4 Wochen / 4 weeks x auf Anfrage / upon request

● empfohlen / recommended

o bedingt einsetzbar / alternative recommendation

- nicht geeignet / not suitable

■ unbeschichtete HM-Sorten / uncoated grades

■ beschichtete HM-Sorten / coated grades

■ bestückt/Cermet / brazed/Cermet

P	•
M	•
K	•
N	•
S	•
H	-

Abmessungen in mm

Dimensions in mm

Ausführung R oder L angeben

State R or L version

Keine Unterlegplatte erforderlich. Sämtliche HORN-Gewindeprofile sind mit einem **KEGELMANTEL-FREISCHLIFF** versehen.
No shims necessary. All HORN thread profiles are manufactured with **full ground radial clearance**.

HM-Sorten
Carbide grades

274

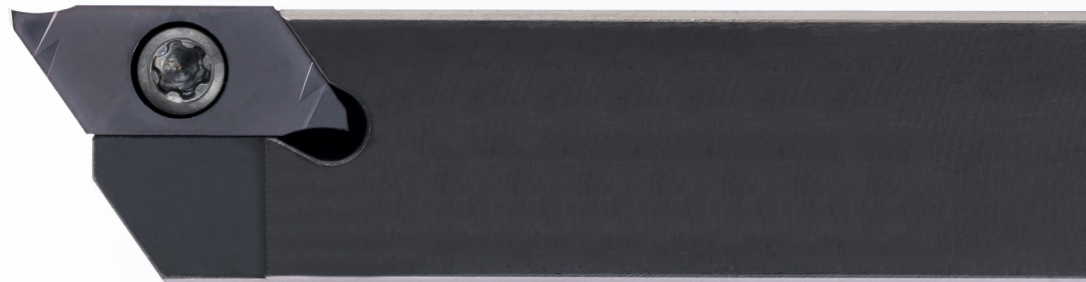

**Klemmhalter mit
Schneidplatten**

Stechbreite 0,5 - 7 mm

**Toolholder with
Inserts**

Width of groove 0,5 - 7 mm

F

Einstecken und Längsdrehen

Grooving and Side Turning



Klemmhalter
Toolholder
H274/H274...E/
HC274

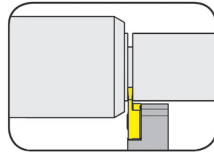

Seite/Page
F3

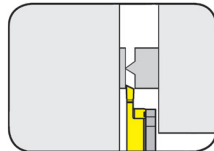

Seite/Page
F4-F5, F29

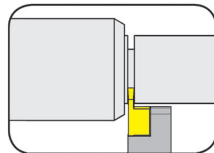

Seite/Page
F6

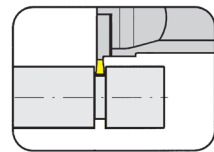

Seite/Page
F8

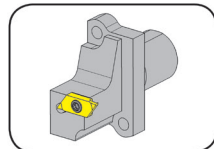

Seite/Page
F9

Klemmhalter Graf
Toolholder Graf
974



Seite/Page
F7

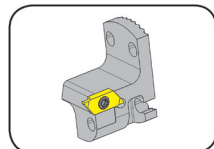

Seite/Page
F10-F11

Einbauhalter
Cartridge
KT274/KTC274



Seite/Page
F12

Wendeschneidplatte
Indexable insert
S274/S274...E

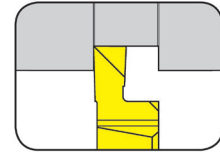

Seite/Page
F13-F14, F30-F31

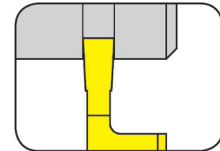

Seite/Page
F15-F17, F32-F34

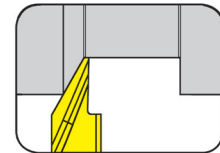

Seite/Page
F18, F35

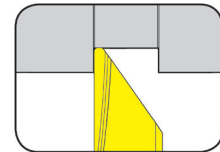

Seite/Page
F19, F36

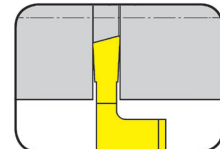

Seite/Page
F20-F25, F37-F42

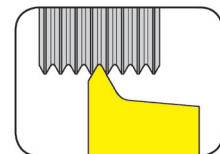

Seite/Page
F26, F43

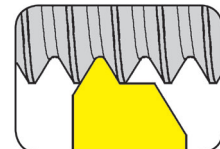

Seite/Page
F27-F28, F44-F45

F

Abstechen

Parting Off



Klemmhalter

Toolholder

H274

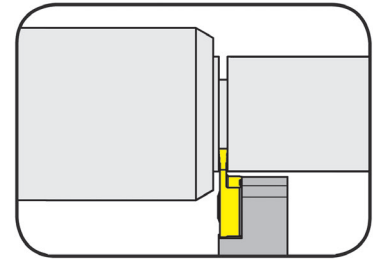

Stechtiefe	Depth of groove	6 mm
Stechbreite	Width of groove	0,5-3 mm

für Wendeschneidplatte
for Indexable insert

Typ S274
Type

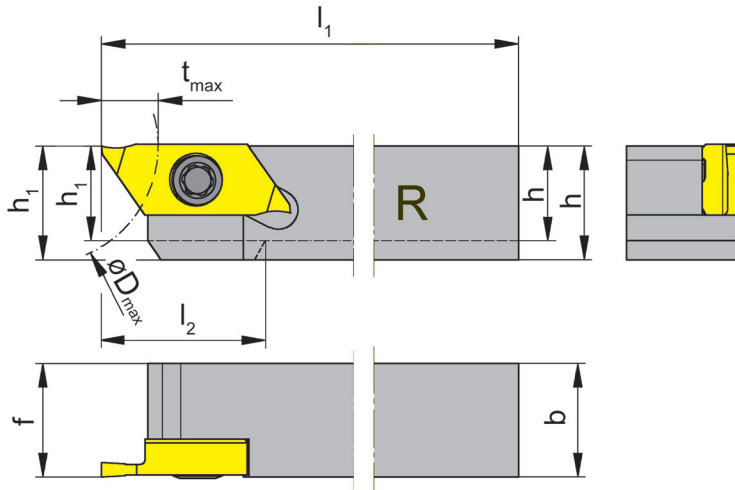

R = rechts wie gezeichnet
R = right hand version shown

L = links spiegelbildlich
L = left hand version

Bestellnummer Part number	h	b	l ₁	l ₂	h ₁	f	t _{max}	D _{max}	Größe Size
R/LH274.0808.04	8	8	100	16	8	8	6	25	04
R/LH274.1010.04	10	10	100	-	10	10	6	25	04
R/LH274.1212.04	12	12	100	-	12	12	6	25	04
R/LH274.1414.04	14	14	100	-	14	14	6	25	04
R/LH274.1616.04	16	16	125	-	16	16	6	25	04

Ausführung R oder L angeben
State R or L version

Weitere Abmessungen auf Anfrage
Further sizes upon request

Das Anzugsdrehmoment der Schrauben finden Sie in den Technischen Hinweisen.
For torque specification of the screw, please see Technical Instructions.

Abmessungen in mm
Dimensions in mm

Ersatzteile

Spare Parts

Klemmhalter Toolholder	Spannschraube Clamping Screw	TORX PLUS®-Schlüssel TORX PLUS® Wrench
R/LH274.0808.04	030.350P.0744	T15PQ
R/LH274....	030.3509.T15P	T15PQ

F

Einstecken und Drehen

Grooving and Turning



Klemmhalter

Toolholder

H274

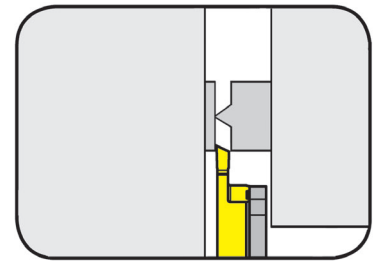

Stechtiefe	Depth of groove	6 mm
Stechbreite	Width of groove	0,5-3 mm

für Wendeschneidplatte
for Indexable insert

Typ S274
Type

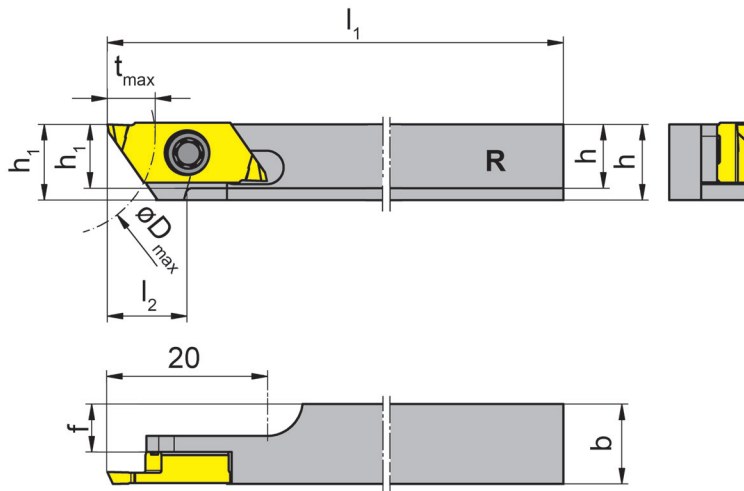

R = rechts wie gezeichnet
R = right hand version shown

Bestellnummer Part number	h	b	l ₁	l ₂	h ₁	f	t _{max}	D _{max}	Größe Size
RH274.0808.6.04	8	8	100	10	9,5	4	6	25	04
RH274.1010.6.04	10	10	100	10	9,5	6	6	25	04
RH274.1212.6.04	12	12	100	10	9,5	8	6	25	04

Abmessungen in mm
Dimensions in mm

Weitere Abmessungen auf Anfrage
Further sizes upon request

Das Anzugsdrehmoment der Schrauben finden Sie in den Technischen Hinweisen.
For torque specification of the screw, please see Technical Instructions.

Ersatzteile

Spare Parts

Klemmhalter Toolholder	Spannschraube Clamping Screw	TORX PLUS®-Schlüssel TORX PLUS® Wrench
RH274...	030.350P.0981	T15PQ

Einstecken und Drehen

Grooving and Turning



Klemmhalter

Toolholder

H274

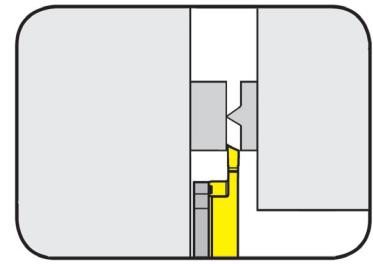

Stechtiefe Stechbreite	Depth of groove Width of groove	6 mm 0,5-3 mm
---------------------------	------------------------------------	------------------

für Wendeschneidplatte
for Indexable insert

Typ S274
Type

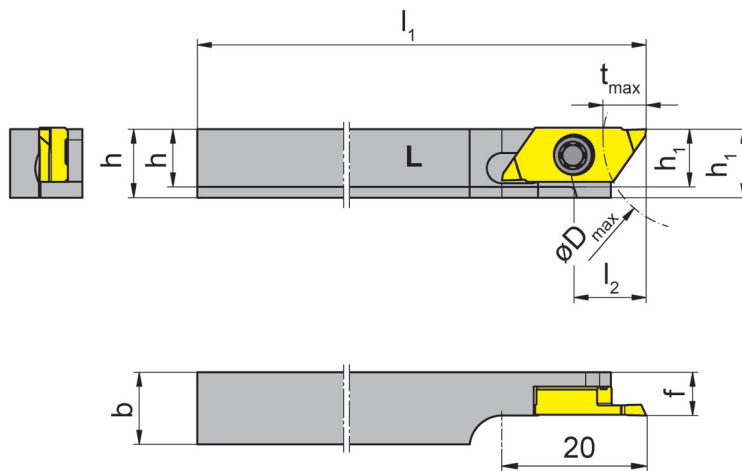

L = links wie gezeichnet
L = left hand version shown

Bestellnummer Part number	h	b	l ₁	l ₂	h ₁	f	t _{max}	D _{max}	Größe Size
LH274.0808.6.04.M	8	8	100	10	9,5	6	6	25	04
LH274.1010.6.04.M	10	10	100	10	9,5	6	6	25	04
LH274.1212.6.04.M	12	12	100	10	9,5	6	6	25	04

Abmessungen in mm
Dimensions in mm

Weitere Abmessungen auf Anfrage
Further sizes upon request

Das Anzugsdrehmoment der Schrauben finden Sie in den Technischen Hinweisen.
For torque specification of the screw, please see Technical Instructions.

Ersatzteile

Spare Parts

Klemmhalter Toolholder	Spannschraube Clamping Screw	TORX PLUS®-Schlüssel TORX PLUS® Wrench
LH274...	030.350P.0981	T15PQ



Einstecken und Drehen

Grooving and Turning



Klemmhalter

Toolholder

H274

Stechtiefe Stechbreite bis	Depth of groove Width of groove up to	6 mm 7 mm
-------------------------------	--	--------------

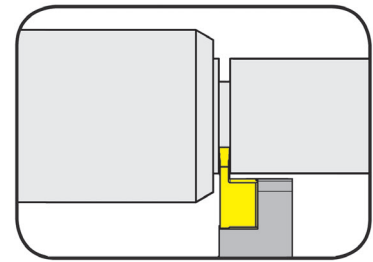

für Wendeschneidplatte
for Indexable insert

Typ S274 Sonder / Special
Type

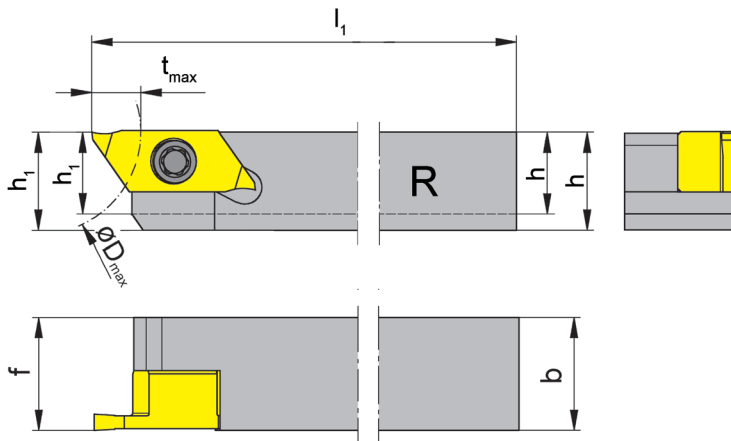

R = rechts wie gezeichnet
R = right hand version shown

L = links spiegelbildlich
L = left hand version

für Sonderbreiten
for special widths

Bestellnummer Part number	h	b	l ₁	h ₁	f	t _{max}	D _{max}	Größe Size
R/LH274.1214.07	12	14	100	12	14	6	25	07
R/LH274.1616.07	16	16	125	16	16	6	25	07

Ausführung R oder L angeben
State R or L version

Weitere Abmessungen auf Anfrage
Further sizes upon request

Das Anzugsdrehmoment der Schrauben finden Sie in den Technischen Hinweisen.
For torque specification of the screw, please see Technical Instructions.

Abmessungen in mm
Dimensions in mm

Ersatzteile

Spare Parts

Klemmhalter Toolholder	Spannschraube Clamping Screw	TORX PLUS®-Schlüssel TORX PLUS® Wrench
R/LH274...	030.3513.T15P	T15PQ

Einstecken und Längsdrehen

Grooving and Side Turning



Klemmhalter Graf

Toolholder Graf

974

mit innerer Kühlmittelzufuhr
with through coolant supply



Stechtiefe
Stechbreite

Depth of groove
Width of groove

6 mm
0,5-3 mm

für Wendeschneidplatte
for Indexable insert

Typ S274
Type

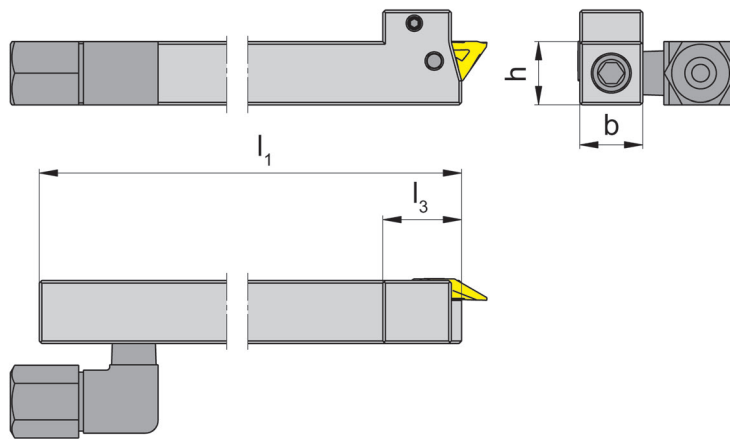

R = rechts wie gezeichnet
R = right hand version shown

L = links spiegelbildlich
L = left hand version

Bestellnummer Part number	h	b	l ₁	l ₃	Größe Size
974.L.1012.04.IK	10	12	100	15	04
974.R.1012.04.IK	10	12	100	15	04
974.L.1212.04.IK	12	12	100	15	04
974.R.1212.04.IK	12	12	100	15	04
974.L.1616.04.IK	16	16	100	15	04
974.R.1616.04.IK	16	16	100	15	04

Weitere Abmessungen auf Anfrage
Further sizes upon request

Abmessungen in mm
Dimensions in mm

Das Anzugsdrehmoment der Schrauben finden Sie in den Technischen Hinweisen.
For torque specification of the screw, please see Technical Instructions.

F

Einstecken und Längsdrehen (außen)

Grooving and Side Turning (external)



Klemmhalter

Toolholder

HC274

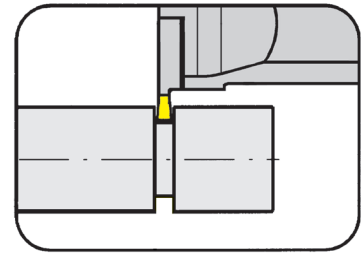

Stechtiefe bis	Depth of groove up to	4 mm
Stechbreite bis	Width of groove up to	3 mm

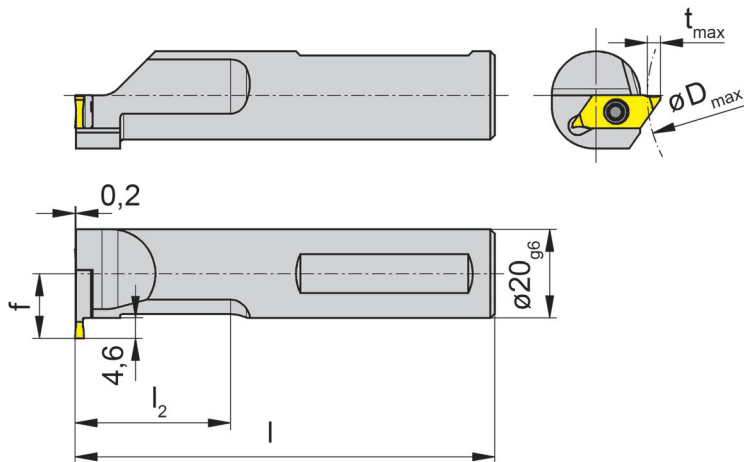

für Wendeschneidplatte
for Indexable insert

Typ S274
Type

TRAUB TNL 18 / 32

R = rechts wie gezeichnet
R = right hand version shown

Bestellnummer Part number	l	l ₂	f	t _{max}	Größe Size
RHC274.0020.1.04	95	35	14,6	4	04

Weitere Abmessungen auf Anfrage
Further sizes upon request

Abmessungen in mm
Dimensions in mm

Bestellhinweis:

Linke Wendeschneidplatte für rechten Klemmhalter verwenden.

Ordering note:

Use left hand insert in right hand toolholder.

Das Anzugsdrehmoment der Schrauben finden Sie in den Technischen Hinweisen.

For torque specification of the screw, please see Technical Instructions.

Ersatzteile

Spare Parts

Klemmhalter Toolholder	Spannschraube Clamping Screw	TORX PLUS®-Schlüssel TORX PLUS® Wrench
RHC274.0020.1.04	030.3509.T15P	T15PQ

Einstecken und Drehen

Grooving and Turning



Klemmhalter

Toolholder

H274

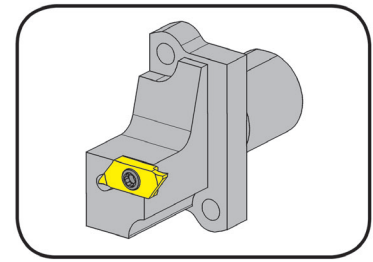

Stechtiefe bis	Depth of groove up to	6 mm
Stechbreite bis	Width of groove up to	7 mm

Lochbild 13,7 x 37,6 mm
Hole pattern 13,7 x 37,6 mm

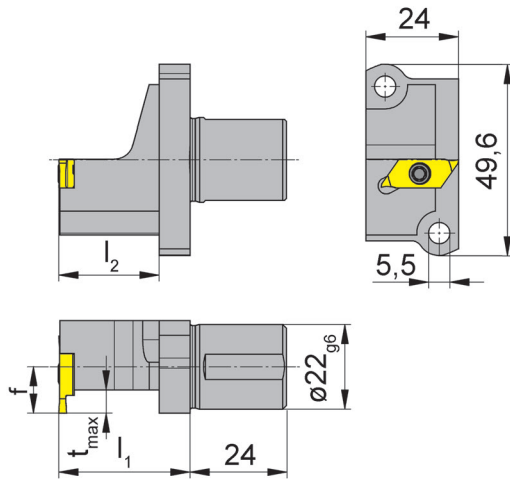

für Wendeschneidplatte
for Indexable insert

Typ S274
Type

für Star
Langdrehautomaten
for Swiss type machines Star

R = rechts wie gezeichnet
R = right hand version shown

L = links spiegelbildlich
L = left hand version

Bestellnummer Part number	f	l ₁	t _{max}	l ₂	Größe Size
R/LH274.A022.09.04	9	34	6	26	04
R/LH274.A022.12.04	12	34	6	26	04
R/LH274.A022.16.04	16	34	6	26	04
R/LH274.A022.09.07	9	34	6	26	07
R/LH274.A022.12.07	12	34	6	26	07

Ausführung R oder L angeben
State R or L version

Abmessungen in mm
Dimensions in mm

Weitere Abmessungen auf Anfrage
Further sizes upon request

Bestellhinweis:

Rechte WSP in linken, linke WSP in rechten Klemmhaltern verwenden.

Ordering note:

Use right hand inserts in left hand toolholders and left hand inserts in right hand toolholders

Das Anzugsdrehmoment der Schrauben finden Sie in den Technischen Hinweisen.

For torque specification of the screw, please see Technical Instructions.

Ersatzteile

Spare Parts

Klemmhalter Toolholder	Spannschraube Clamping Screw	TORX PLUS®-Schlüssel TORX PLUS® Wrench
R/LH274...	030.3513.T15P	T15PQ

F

Einstecken und Längsdrehen

Grooving and Side Turning



Einbauhalter

Cartridge

KT274

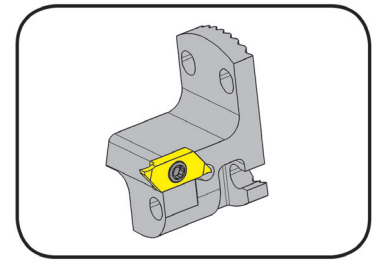

Stechtiefe bis
Stechbreite

Depth of groove up to
Width of groove

6 mm
0,5-3 mm

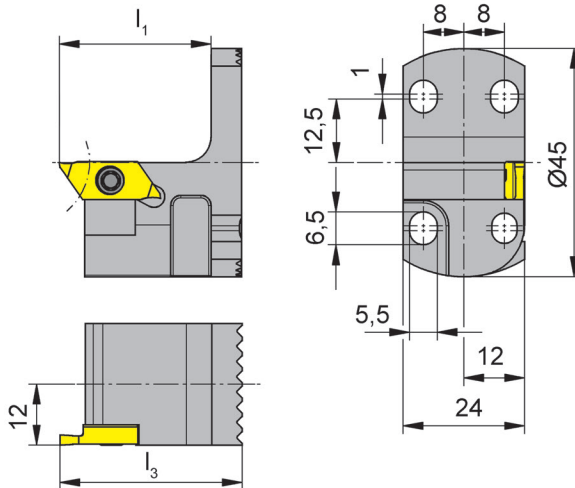

R = rechts wie gezeichnet
R = right hand version shown

L = links spiegelbildlich
L = left hand version

für Wendeschneidplatte
for Indexable insert

Typ S274
Type

Bestellnummer Part number	l_3	l_1	Größe Size
R/LKT274.2445.04	36	30	04

Ausführung R oder L angeben
State R or L version

Weitere Abmessungen auf Anfrage
Further sizes upon request

Das Anzugsdrehmoment der Schrauben finden Sie in den Technischen Hinweisen.
For torque specification of the screw, please see Technical Instructions.

Abmessungen in mm
Dimensions in mm

Ersatzteile

Spare Parts

Einbauhalter Cartridge	Spannschraube Clamping Screw	TORX PLUS®-Schlüssel TORX PLUS® Wrench
R/LKT274.2445.04	030.3509.T15P	T15PQ

Einstecken und Längsdrehen

Grooving and Side Turning



Einbauhalter

Cartridge

KTC274

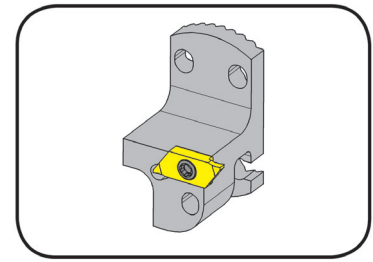

Stechtiefe bis
Stechbreite

Depth of groove up to
Width of groove

6 mm
0,5-3 mm

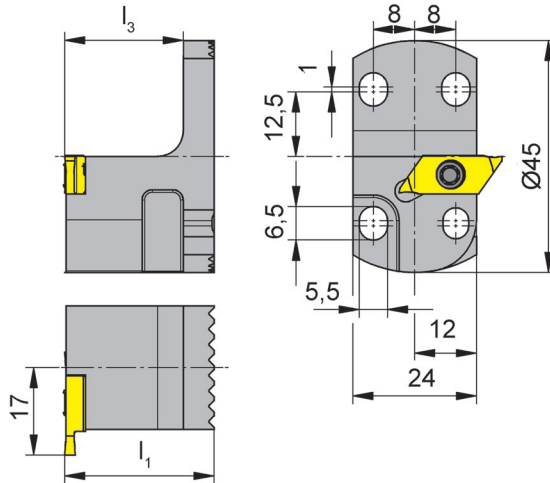

R = rechts wie gezeichnet
R = right hand version shown

für Wendeschneidplatte
for Indexable insert

Typ S274
Type

Bestellnummer Part number	l_1	l_3	Größe Size
RKTC274.2445.04	29	23	04

Weitere Abmessungen auf Anfrage
Further sizes upon request

Abmessungen in mm
Dimensions in mm

Bestellhinweis:

Linke Wendeschneidplatte für rechten Klemmhalter verwenden.

Ordering note:

Use left hand insert in right hand toolholder.

Das Anzugsdrehmoment der Schrauben finden Sie in den Technischen Hinweisen.

For torque specification of the screw, please see Technical Instructions.

Ersatzteile

Spare Parts

Einbauhalter Cartridge	Spannschraube Clamping Screw	TORX PLUS®-Schlüssel TORX PLUS® Wrench
RKTC274.2445.04	030.3509.T15P	T15PQ

F

Einbauhalter Graf

Cartridge Graf

76

mit innerer Kühlmittelzufuhr
with through coolant supply



Stechtiefe
Stechbreite

Depth of groove
Width of groove

6 mm
0,5-3 mm

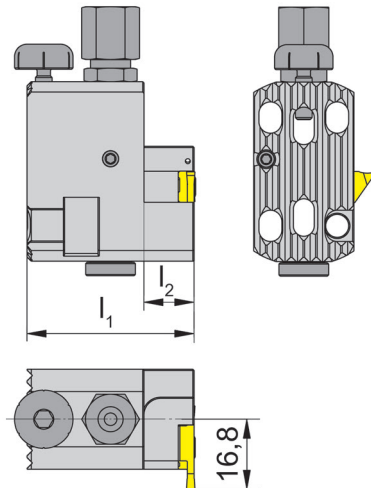

für Wendeschneidplatte
for Indexable insert

Typ S274
Type

R = rechts wie gezeichnet
R = right hand version shown

Bestellnummer Part number	l_1	l_2	Größe Size
R76IK	40	12	04

Weitere Abmessungen auf Anfrage
Further sizes upon request

Abmessungen in mm
Dimensions in mm

Bestellhinweis:

Linke Wendeschneidplatte für rechten Klemmhalter verwenden.

Ordering note:

Use left hand insert in right hand toolholder.

Das Anzugsdrehmoment der Schrauben finden Sie in den Technischen Hinweisen.

For torque specification of the screw, please see Technical Instructions.

Ersatzteile

Spare Parts

Einbauhalter Graf Cartridge Graf	Höhenverstellungsschraube Screw to adjust the height	Kühlmittelanschluss Coolant supply	Spannschraube Clamping Screw	TORX PLUS®-Schlüssel TORX PLUS® Wrench
R76IK	002.00.69	004.00.19	030.3509.T15P	T15PQ

Einstecken und Längsdrehen

Grooving and Side Turning



Wendeschneidplatte

Indexable insert

S274

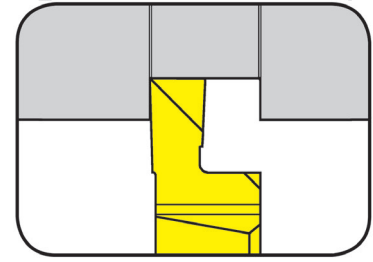

Stechtiefe bis Stechbreite	Depth of groove up to Width of groove	4,5 mm 0,5-3 mm
-------------------------------	--	--------------------

präzisionsgeschliffen
precision ground

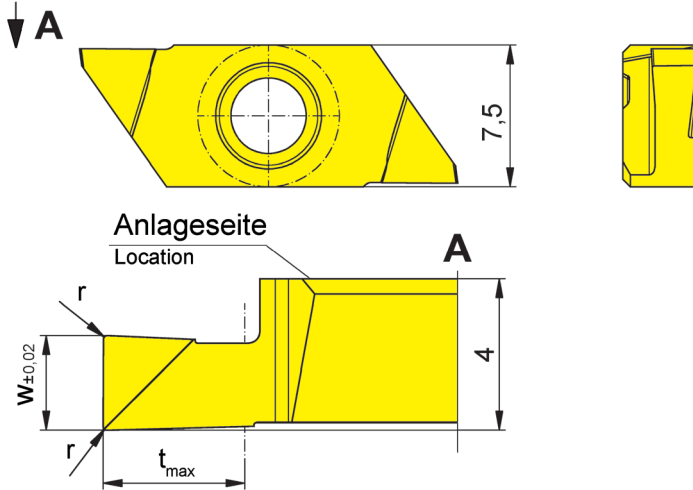

für Klemhalter
for Toolholder

Typ H274
Type KT274
KTC274
974
76
H274KM
HC274KM

R = rechts wie gezeichnet
R = right hand version shown

L = links spiegelbildlich
L = left hand version

Wechselgenauigkeit
Länge ± 0,015 mm
Indexability length
± 0,015 mm

Bestellnummer Part number	w	r	t _{max}	Größe Size	AN25	IG35	TH35	
R/LS274.0050.P0	0,5	-	1,00	04	▲/▲	▲/▲	▲/▲	
R/LS274.0100.P0	1,0	-	2,00	04	▲/▲	▲/▲	▲/▲	
R/LS274.0150.P0	1,5	0,05	2,25	04		▲/▲	▲/▲	
R/LS274.0200.P0	2,0	0,05	3,00	04		▲/Δ	▲/▲	
R/LS274.0250.P0	2,5	0,10	3,75	04		▲/▲	▲/▲	
R/LS274.0300.P0	3,0	0,10	4,50	04		▲/Δ	▲/▲	
					P	•	-	•
					M	o	•	•
					K	-	-	•
					N	-	-	•
					S	-	•	•
					H	-	-	-

Abmessungen in mm
Dimensions in mm

Ausführung R oder L angeben
State R or L version

HM-Sorten
Carbide grades

- ▲ ab Lager / on stock Δ 4 Wochen / 4 weeks x auf Anfrage / upon request
- empfohlen / recommended
- o bedingt einsetzbar / alternative recommendation
- nicht geeignet / not suitable
- unbeschichtete HM-Sorten / uncoated grades
- beschichtete HM-Sorten / coated grades
- bestückt/Cermet / brazed/Cermet



Einstechen und Längsdrehen

Grooving and Side Turning



Wendeschneidplatte

Indexable insert

S274

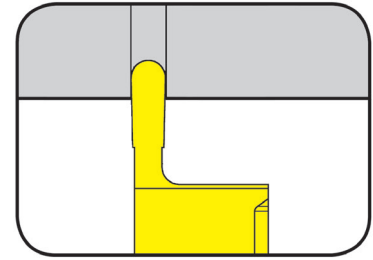

Stechtiefe bis Vollradius	Depth of groove up to Full radius	4 mm 0,25-1 mm
---------------------------	-----------------------------------	-------------------

präzisionsgeschliffen
precision ground

für Klemhalter
for Toolholder

Typ H274
Type KT274
KTC274
974
76
H274KM
HC274KM

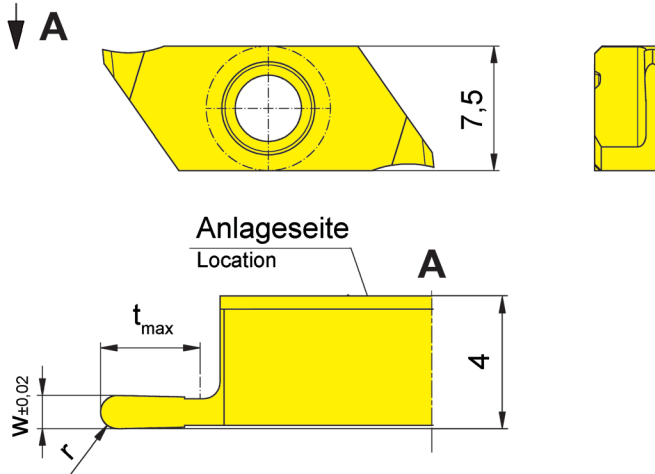

R = rechts wie gezeichnet
R = right hand version shown

L = links spiegelbildlich
L = left hand version

Wechselgenauigkeit
Länge ± 0,015 mm
Indexability length
± 0,015 mm

F

Bestellnummer Part number	w	t _{max}	r	Größe Size	IG35	TH35
R/LS274.0205.01.10	0,5	1,5	0,25	04	▲/▲	▲/▲
R/LS274.0510.03.10	1,0	3,0	0,50	04	▲/▲	▲/▲
R/LS274.1020.04.10	2,0	4,0	1,00	04	▲/▲	▲/▲

▲ ab Lager / on stock Δ 4 Wochen / 4 weeks x auf Anfrage / upon request

● empfohlen / recommended

o bedingt einsetzbar / alternative recommendation

- nicht geeignet / not suitable

■ unbeschichtete HM-Sorten / uncoated grades

■ beschichtete HM-Sorten / coated grades

■ bestückt/Cermet / brazed/Cermet

Abmessungen in mm

Dimensions in mm

Ausführung R oder L angeben

State R or L version

P	-	•
M	•	•
K	-	•
N	-	•
S	•	•
H	-	-

HM-Sorten
Carbide grades

Einstechen und Abstechen

Grooving and Parting Off



Wendeschneidplatte

Indexable insert

S274

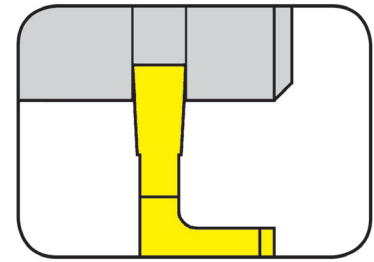

Stechtiefe bis Stechbreite	Depth of groove up to Width of groove	6 mm 0,5-2 mm
-------------------------------	--	------------------

präzisionsgeschliffen
precision ground

für Klemmhalter
for Toolholder

Typ H274
Type KT274
KTC274
974
76
H274KM
HC274KM

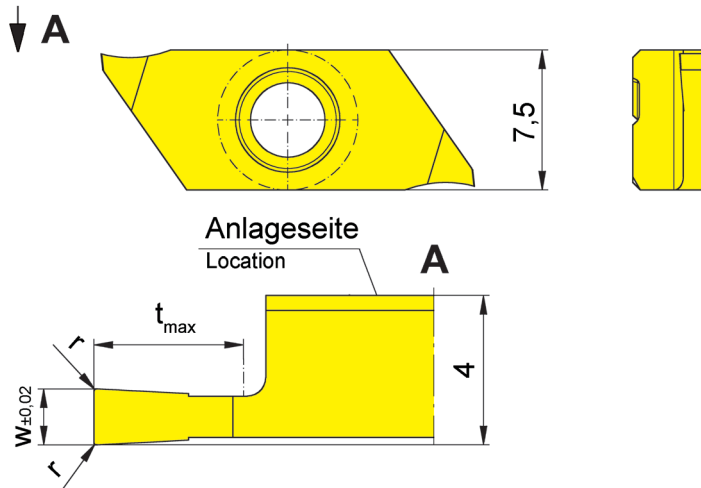

R = rechts wie gezeichnet
R = right hand version shown

L = links spiegelbildlich
L = left hand version

Wechselgenauigkeit
Länge ± 0,015 mm
Indexability length
± 0,015 mm

Bestellnummer Part number	w	r	t _{max}	Größe Size	IG35	TH35
R/LS274.0050.01.10	0,5	0,05	1,5	04	▲/▲	▲/▲
R/LS274.0070.02.10	0,7	0,05	2,0	04	x/Δ	▲/Δ
R/LS274.0080.03.10	0,8	0,05	3,0	04	▲/▲	▲/▲
R/LS274.0100.03.10	1,0	0,05	3,0	04	▲/▲	▲/▲
R/LS274.0120.03.10	1,2	0,05	3,0	04	▲/▲	▲/▲
R/LS274.0150.04.10	1,5	0,05	4,0	04	▲/▲	▲/▲
R/LS274.0150.06.10	1,5	0,05	6,0	04	▲/▲	▲/▲
R/LS274.0200.04.10	2,0	0,05	4,0	04	▲/▲	▲/▲
R/LS274.0200.06.10	2,0	0,05	6,0	04	▲/▲	▲/▲

▲ ab Lager / on stock Δ 4 Wochen / 4 weeks x auf Anfrage / upon request

● empfohlen / recommended

o bedingt einsetzbar / alternative recommendation

- nicht geeignet / not suitable

■ unbeschichtete HM-Sorten / uncoated grades

■ beschichtete HM-Sorten / coated grades

■ bestückt/Cermet / brazed/Cermet

Abmessungen in mm

Dimensions in mm

Ausführung R oder L angeben

State R or L version

P	-	●
M	●	●
K	-	●
N	-	●
S	●	●
H	-	-

HM-Sorten
Carbide grades



Einstechen und Abstechen

Grooving and Parting Off



Wendeschneidplatte

Indexable insert

S274

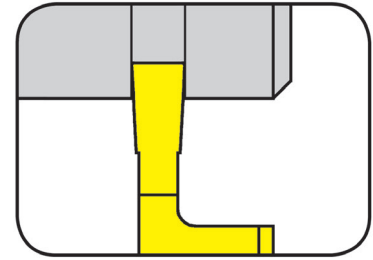

Stechtiefe bis Stechbreite	Depth of groove up to Width of groove	6 mm 0,5-2 mm
-------------------------------	--	------------------

präzisionsgeschliffen
precision ground

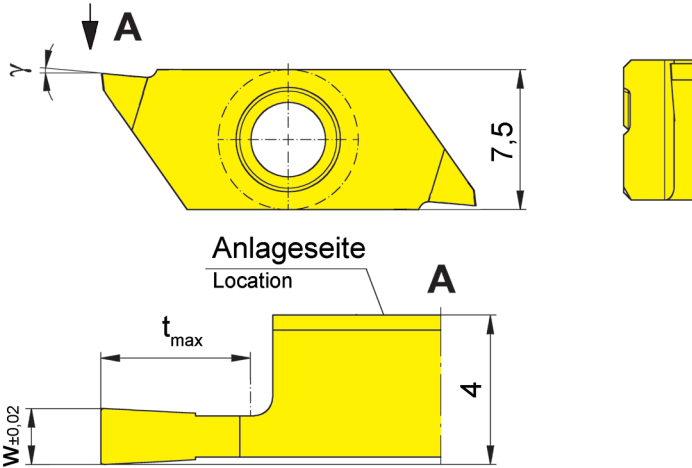

für Klemhalter
for Toolholder

Typ H274
Type KT274
KTC274
974
76
H274KM
HC274KM

Wechselgenauigkeit
Länge ± 0,015 mm
Indexability length
± 0,015 mm

R = rechts wie gezeichnet
R = right hand version shown

L = links spiegelbildlich
L = left hand version

Bestellnummer Part number	w	t _{max}	γ	Größe Size	IG35	TH35
R/LS274.0050.01.20	0,5	1,5	5°	04	▲/▲	▲/▲
R/LS274.0070.02.20	0,7	2,0	5°	04	Δ/Δ	▲/▲
R/LS274.0080.03.20	0,8	3,0	5°	04	Δ/Δ	▲/Δ
R/LS274.0100.03.20	1,0	3,0	5°	04	▲/Δ	▲/Δ
R/LS274.0120.03.20	1,2	3,0	5°	04	Δ/Δ	▲/Δ
R/LS274.0150.04.20	1,5	4,0	5°	04	▲/▲	▲/▲
R/LS274.0150.06.20	1,5	6,0	5°	04	Δ/Δ	Δ/▲
R/LS274.0200.04.20	2,0	4,0	5°	04	Δ/Δ	▲/Δ
R/LS274.0200.06.20	2,0	6,0	5°	04	Δ/Δ	▲/Δ

▲ ab Lager / on stock Δ 4 Wochen / 4 weeks x auf Anfrage / upon request

● empfohlen / recommended

o bedingt einsetzbar / alternative recommendation

- nicht geeignet / not suitable

■ unbeschichtete HM-Sorten / uncoated grades

■ beschichtete HM-Sorten / coated grades

■ bestückt/Cermet / brazed/Cermet

Abmessungen in mm

Dimensions in mm

Ausführung R oder L angeben

State R or L version

P	-	•
M	•	•
K	-	•
N	-	•
S	•	•
H	-	-

HM-Sorten
Carbide grades

F

Einstechen und Abstechen

Grooving and Parting Off



Wendeschneidplatte

Indexable insert

S274

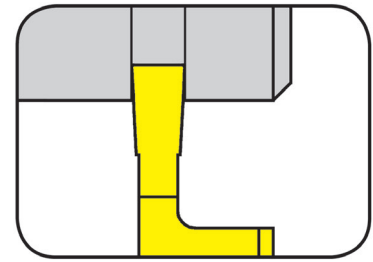

Stechtiefe bis Stechbreite	Depth of groove up to Width of groove	6 mm 0,5-2 mm
-------------------------------	--	------------------

präzisionsgeschliffen
precision ground

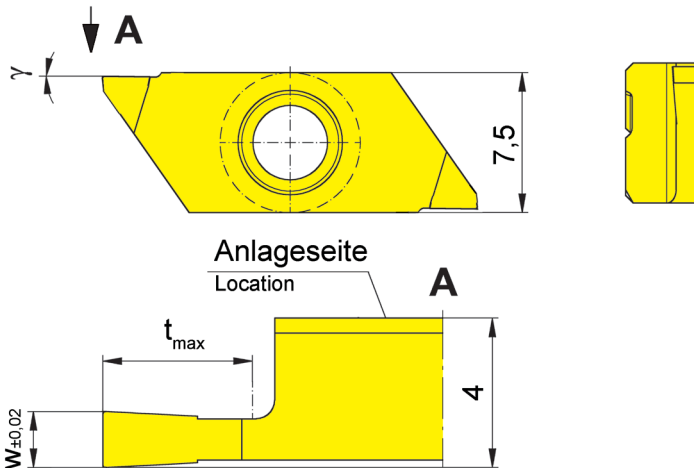

für Klemhalter
for Toolholder

Typ H274
Type KT274
KTC274
974
76
H274KM
HC274KM

Wechselgenauigkeit
Länge ± 0,015 mm
Indexability length
± 0,015 mm

R = rechts wie gezeichnet
R = right hand version shown

L = links spiegelbildlich
L = left hand version

Bestellnummer Part number	w	t _{max}	γ	Größe Size	IG35	TH35
R/LS274.0050.01.M0	0,5	1,5	0°	04	Δ/Δ	▲/Δ
R/LS274.0070.02.M0	0,7	2,0	0°	04	Δ/▲	Δ/Δ
R/LS274.0080.03.M0	0,8	3,0	0°	04	Δ/Δ	Δ/Δ
R/LS274.0100.03.M0	1,0	3,0	0°	04	Δ/Δ	▲/Δ
R/LS274.0120.03.M0	1,2	3,0	0°	04	Δ/Δ	▲/Δ
R/LS274.0150.04.M0	1,5	4,0	0°	04	Δ/Δ	Δ/Δ
R/LS274.0150.06.M0	1,5	6,0	0°	04	Δ/Δ	Δ/Δ
R/LS274.0200.04.M0	2,0	4,0	0°	04	Δ/Δ	Δ/Δ
R/LS274.0200.06.M0	2,0	6,0	0°	04	Δ/Δ	▲/Δ

▲ ab Lager / on stock Δ 4 Wochen / 4 weeks x auf Anfrage / upon request

● empfohlen / recommended

o bedingt einsetzbar / alternative recommendation

- nicht geeignet / not suitable

■ unbeschichtete HM-Sorten / uncoated grades

■ beschichtete HM-Sorten / coated grades

■ bestückt/Cermet / brazed/Cermet

Abmessungen in mm

Dimensions in mm

Ausführung R oder L angeben

State R or L version

P	-	•
M	•	•
K	-	•
N	-	•
S	•	•
H	-	-

HM-Sorten
Carbide grades



Rückwärtsdrehen (außen)

Backturning (external)



Wendeschneidplatte S274

Indexable insert

Schnitttiefe bis Depth of cut up to 6 mm

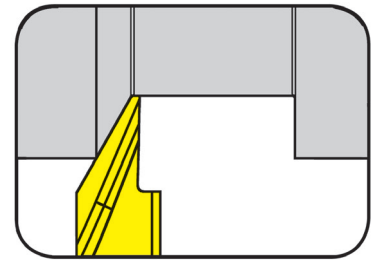

präzisionsgeschliffen
precision ground

für Klemhalter
for Toolholder

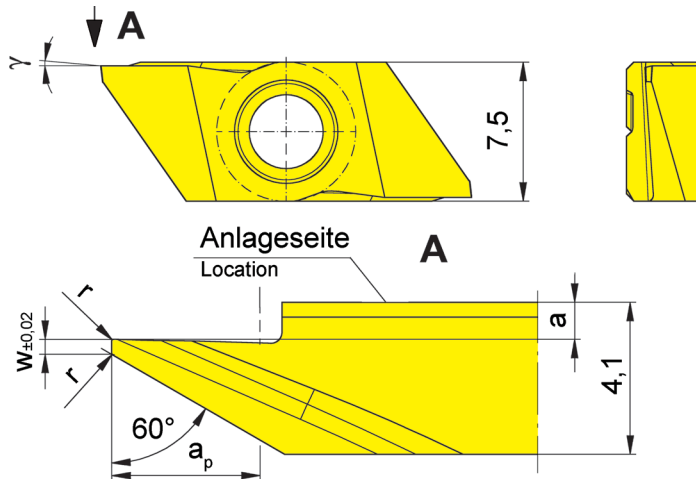

Typ H274
Type KT274
 KTC274
 974
 76
 H274KM
 HC274KM

Wechselgenauigkeit
Länge ± 0,015 mm
Indexability length
± 0,015 mm

R = rechts wie gezeichnet
R = right hand version shown

L = links spiegelbildlich
L = left hand version

Bestellnummer Part number	w	r	a	γ	a _p	Größe Size	K10	IG35	TH35
R/LS274.0460.04.10	0,4	0,05	1,00	15°	4	04	▲/▲	▲/▲	▲/▲
R/LS274.0460.04.M0	0,4	0,05	1,00	0°	4	04	▲/Δ	Δ/Δ	Δ/Δ
R/LS274.0560.06.11	0,5	0,10	0,05	15°	6	04	▲/▲	▲/▲	▲/▲
R/LS274.0060.04.10	-	0,05	1,00	15°	4	04	▲/Δ	▲/Δ	▲/Δ

▲ ab Lager / on stock Δ 4 Wochen / 4 weeks x auf Anfrage / upon request

● empfohlen / recommended

o bedingt einsetzbar / alternative recommendation

- nicht geeignet / not suitable

■ unbeschichtete HM-Sorten / uncoated grades

■ beschichtete HM-Sorten / coated grades

■ bestückt/Cermet / brazed/Cermet

Abmessungen in mm

Dimensions in mm

Ausführung R oder L angeben

State R or L version

γ = Spanwinkel

γ = rake angle

P	●	-	●
M	○	●	●
K	●	-	●
N	●	-	●
S	○	●	●
H	-	-	-

HM-Sorten
Carbide grades

F

Längsdrehen

Side Turning



Wendeschneidplatte

Indexable insert

S274

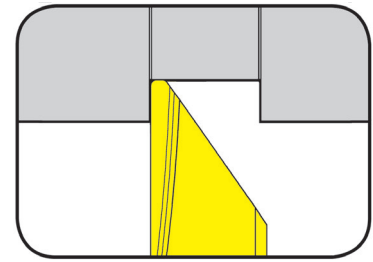

Schnitttiefe bis Depth of cut up to 6 mm

präzisionsgeschliffen
precision ground

für Klemhalter
for Toolholder

Typ H274
Type KT274
 KTC274
 974
 76
 H274KM
 HC274KM

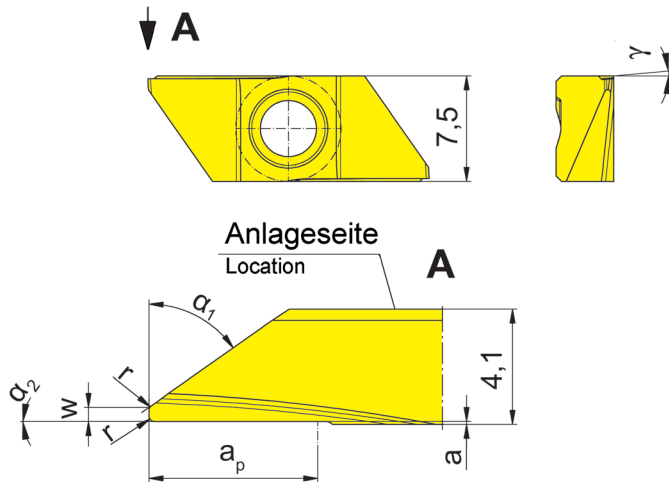

R = rechts wie gezeichnet
R = right hand version shown

L = links spiegelbildlich
L = left hand version

Wechselgenauigkeit
Länge $\pm 0,015$ mm
Indexability length
 $\pm 0,015$ mm

Bestellnummer Part number	w	r	α_1	a	γ	a_p	α_2	Größe Size	IG35	TH35
R/LS274.0035.04.20	-	0,05	35°	0,1	5°	4	0°	04	▲/△	▲/△
R/LS274.0235.04.20	0,2	-	35°	0,1	5°	4	0°	04	▲/△	▲/▲
R/LS274.0535.06.20	0,5	0,20	35°	0,1	5°	6	0°	04	▲/△	▲/△
R/LS274.0055.04.20	-	0,05	55°	0,1	5°	4	0°	04	△/△	▲/▲
R/LS274.0255.04.20	0,2	-	55°	0,1	5°	4	0°	04	△/△	▲/△
R/LS274.0555.06.20	0,5	0,20	55°	0,1	5°	6	0°	04	▲/▲	▲/▲

▲ ab Lager / on stock △ 4 Wochen / 4 weeks x auf Anfrage / upon request

● empfohlen / recommended

o bedingt einsetzbar / alternative recommendation

- nicht geeignet / not suitable

■ unbeschichtete HM-Sorten / uncoated grades

■ beschichtete HM-Sorten / coated grades

■ bestückt/Cermet / brazed/Cermet

Abmessungen in mm

Dimensions in mm

Ausführung R oder L angeben

State R or L version

P	-	•
M	•	•
K	-	•
N	-	•
S	•	•
H	-	-

HM-Sorten
Carbide grades



Längsdrehen

Side Turning



Wendeschneidplatte

Indexable insert

S274

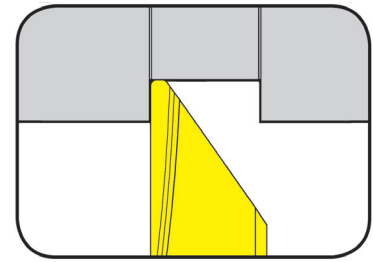

Schnitttiefe bis Depth of cut up to 6 mm

präzisionsgeschliffen
precision ground

für Klemhalter
for Toolholder

Typ H274
Type KT274
 KTC274
 974
 76
 H274KM
 HC274KM

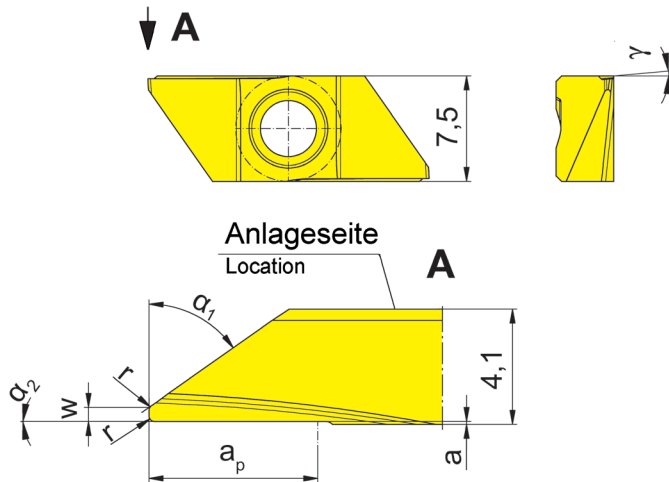

R = rechts wie gezeichnet
R = right hand version shown

L = links spiegelbildlich
L = left hand version

Wechselgenauigkeit
Länge ± 0,015 mm
Indexability length
± 0,015 mm

Bestellnummer Part number	w	r	α_1	a	γ	a_p	α_2	Größe Size	IG35	TH35
R/LS274.0035.24.20	-	0,05	35°	0,1	5°	4	2°	04	▲/▲	▲/▲
R/LS274.0235.24.20	0,2	-	35°	0,1	5°	4	2°	04	▲/▲	▲/▲
R/LS274.0535.26.20	0,5	0,20	35°	0,1	5°	6	2°	04	▲/▲	▲/▲
R/LS274.0055.24.20	-	0,05	55°	0,1	5°	4	2°	04	▲/▲	▲/▲
R/LS274.0255.24.20	0,2	-	55°	0,1	5°	4	2°	04	▲/▲	▲/▲
R/LS274.0555.26.20	0,5	0,20	55°	0,1	5°	6	2°	04	▲/▲	▲/▲

▲ ab Lager / on stock Δ 4 Wochen / 4 weeks x auf Anfrage / upon request

● empfohlen / recommended

o bedingt einsetzbar / alternative recommendation

- nicht geeignet / not suitable

■ unbeschichtete HM-Sorten / uncoated grades

■ beschichtete HM-Sorten / coated grades

■ bestückt/Cermet / brazed/Cermet

Abmessungen in mm

Dimensions in mm

Ausführung R oder L angeben

State R or L version

P	-	•
M	•	•
K	-	•
N	-	•
S	•	•
H	-	-

HM-Sorten
Carbide grades

F

Abstechen

Parting Off



Wendeschneidplatte

Indexable insert

S274

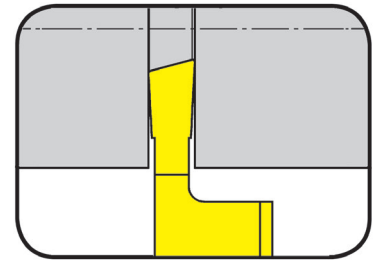

Stechtiefe bis Stechbreite	Depth of groove up to Width of groove	6 mm 0,8-2 mm
-------------------------------	--	------------------

präzisionsgeschliffen
precision ground

für Klemhalter
for Toolholder

Typ H274
Type KT274
KTC274
974
76
H274KM
HC274KM

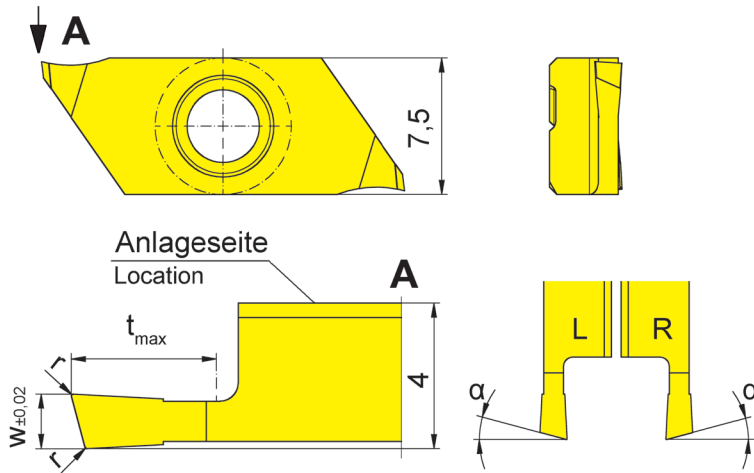

R = rechts wie gezeichnet
R = right hand version shown

L = links spiegelbildlich
L = left hand version

Wechselgenauigkeit
Länge ± 0,015 mm
Indexability length
± 0,015 mm

Bestellnummer Part number	w	r	t _{max}	α	Größe Size	IG35	TH35
R/LS274.1508.03.10	0,8	0,05	3	15°	04	▲/▲	▲/▲
R/LS274.1510.03.10	1,0	0,05	3	15°	04	▲/▲	▲/▲
R/LS274.1515.04.10	1,5	0,05	4	15°	04	▲/▲	▲/▲
R/LS274.1520.06.10	2,0	0,05	6	15°	04	▲/▲	▲/▲

▲ ab Lager / on stock Δ 4 Wochen / 4 weeks x auf Anfrage / upon request

● empfohlen / recommended

o bedingt einsetzbar / alternative recommendation

- nicht geeignet / not suitable

■ unbeschichtete HM-Sorten / uncoated grades

■ beschichtete HM-Sorten / coated grades

■ bestückt/Cermet / brazed/Cermet

Abmessungen in mm

Dimensions in mm

Ausführung R oder L angeben

State R or L version

Hinweis:

t_{max} 6 mm nur bei Werkstück-Ø ≤ 25 mm erreichbar.

Note:

t_{max} 6 mm can be reached only with workpiece Ø ≤ 25 mm.

P	-	●
M	●	●
K	-	●
N	-	●
S	●	●
H	-	-

HM-Sorten
Carbide grades



Abstechen

Parting Off



Wendeschneidplatte

Indexable insert

S274

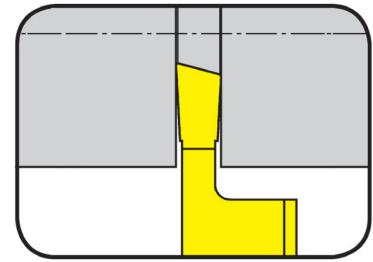

Stechtiefe bis Stechbreite	Depth of groove up to Width of groove	6 mm 0,8-2 mm
-------------------------------	--	------------------

präzisionsgeschliffen
precision ground

für Klemhalter
for Toolholder

Typ H274
Type KT274
KTC274
974
76
H274KM
HC274KM

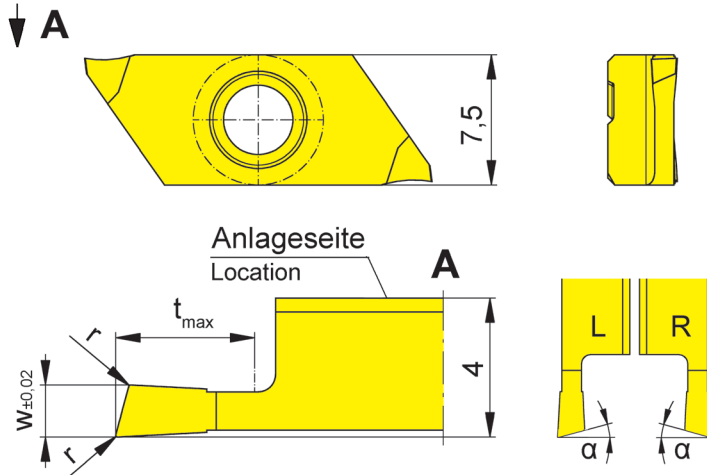

R = rechts wie gezeichnet
R = right hand version shown

L = links spiegelbildlich
L = left hand version

Wechselgenauigkeit
Länge ± 0,015 mm
Indexability length
± 0,015 mm

F

Bestellnummer Part number	w	r	t _{max}	α	Größe Size	IG35	TH35
LS274.1508.03.10R	0,8	0,05	3	15°	04	▲	▲
LS274.1510.03.10R	1,0	0,05	3	15°	04	▲	▲
LS274.1515.04.10R	1,5	0,05	4	15°	04	▲	▲
LS274.1520.06.10R	2,0	0,05	6	15°	04	▲	▲
RS274.1508.03.10L	0,8	0,05	3	15°	04	△	△
RS274.1510.03.10L	1,0	0,05	3	15°	04	△	△
RS274.1515.04.10L	1,5	0,05	4	15°	04	△	△
RS274.1520.06.10L	2,0	0,05	6	15°	04	△	△

- ▲ ab Lager / on stock △ 4 Wochen / 4 weeks x auf Anfrage / upon request
- empfohlen / recommended
- o bedingt einsetzbar / alternative recommendation
- nicht geeignet / not suitable
- unbeschichtete HM-Sorten / uncoated grades
- beschichtete HM-Sorten / coated grades
- bestückt/Cermet / brazed/Cermet

Abmessungen in mm
Dimensions in mm

Hinweis:

t_{max} 6 mm nur bei Werkstück-Ø ≤ 25 mm erreichbar.
Note:
t_{max} 6 mm can be reached only with workpiece Ø ≤ 25 mm.

P	-	●
M	●	●
K	-	●
N	-	●
S	●	●
H	-	-

HM-Sorten
Carbide grades

Abstechen

Parting Off



Wendeschneidplatte

Indexable insert

S274

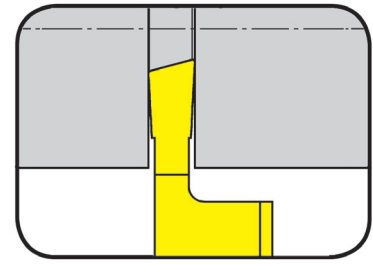

Stechtiefe bis Stechbreite	Depth of groove up to Width of groove	6 mm 1,5-2 mm
-------------------------------	--	------------------

präzisionsgeschliffen
precision ground

für Klemmhalter
for Toolholder

Typ H274
Type KT274
KTC274
974
76
H274KM
HC274KM

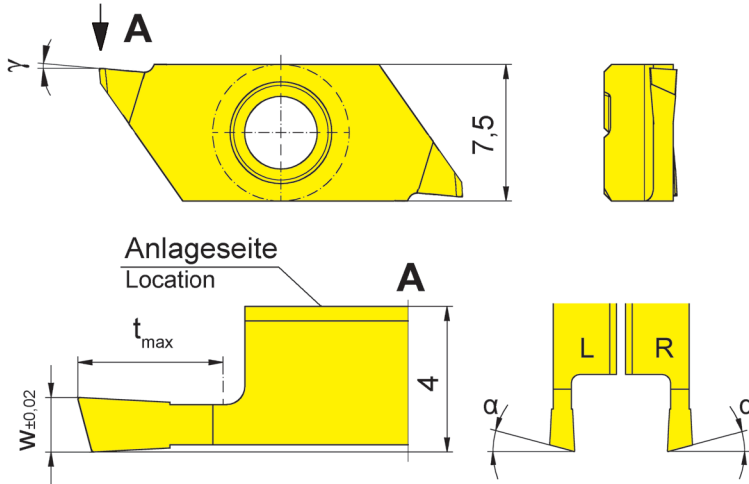

R = rechts wie gezeichnet
R = right hand version shown

L = links spiegelbildlich
L = left hand version

Wechselgenauigkeit
Länge ± 0,015 mm
Indexability length
± 0,015 mm

Bestellnummer Part number	w	t _{max}	α	γ	Größe Size	IG35	TH35
R/LS274.1515.04.20	1,5	4	15°	5°	04	Δ/Δ	Δ/Δ
R/LS274.1520.06.20	2,0	6	15°	5°	04	Δ/Δ	Δ/Δ

▲ ab Lager / on stock Δ 4 Wochen / 4 weeks x auf Anfrage / upon request

● empfohlen / recommended

o bedingt einsetzbar / alternative recommendation

- nicht geeignet / not suitable

■ unbeschichtete HM-Sorten / uncoated grades

■ beschichtete HM-Sorten / coated grades

■ bestückt/Cermet / brazed/Cermet

Abmessungen in mm

Dimensions in mm

Ausführung R oder L angeben

State R or L version

Hinweis:

t_{max} 6 mm nur bei Werkstück-Ø ≤ 25 mm erreichbar.

Note:

t_{max} 6 mm can be reached only with workpiece Ø ≤ 25 mm.

P	-	•
M	•	•
K	-	•
N	-	•
S	•	•
H	-	-

HM-Sorten
Carbide grades



Abstechen

Parting Off



Wendeschneidplatte

Indexable insert

S274

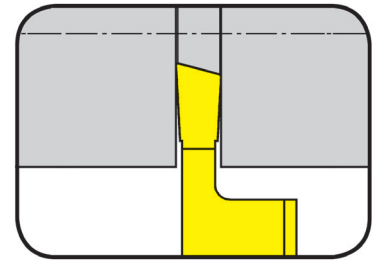

Stechtiefe bis Stechbreite	Depth of groove up to Width of groove	6 mm 1,5-2 mm
-------------------------------	--	------------------

präzisionsgeschliffen
precision ground

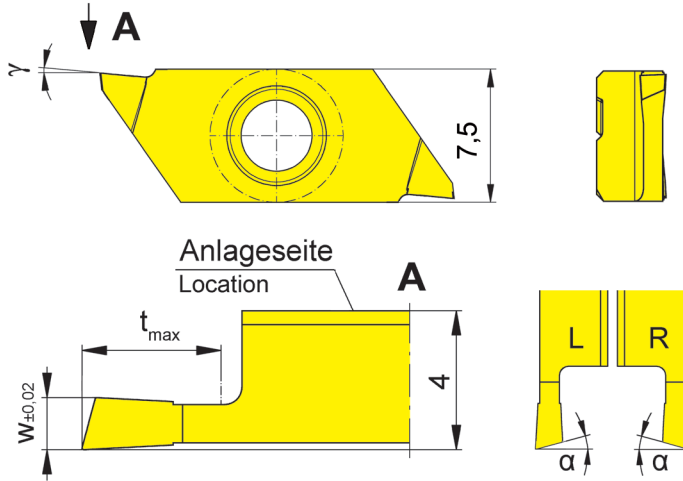

für Klemhalter
for Toolholder

Typ H274
Type KT274
KTC274
974
76
H274KM
HC274KM

Wechselgenauigkeit
Länge $\pm 0,015$ mm
Indexability length
 $\pm 0,015$ mm

R = rechts wie gezeichnet
R = right hand version shown

L = links spiegelbildlich
L = left hand version

Bestellnummer Part number	w	t _{max}	α	γ	Größe Size	IG35	TH35
LS274.1515.04.20R	1,5	4	15°	5°	04	Δ	Δ
LS274.1520.06.20R	2,0	6	15°	5°	04	Δ	Δ
RS274.1515.04.20L	1,5	4	15°	5°	04	Δ	Δ
RS274.1520.06.20L	2,0	6	15°	5°	04	Δ	Δ

▲ ab Lager / on stock Δ 4 Wochen / 4 weeks x auf Anfrage / upon request

● empfohlen / recommended

o bedingt einsetzbar / alternative recommendation

- nicht geeignet / not suitable

■ unbeschichtete HM-Sorten / uncoated grades

■ beschichtete HM-Sorten / coated grades

■ bestückt/Cermet / brazed/Cermet

Abmessungen in mm

Dimensions in mm

Hinweis:

t_{max} 6 mm nur bei Werkstück-Ø ≤ 25 mm erreichbar.

Note:

t_{max} 6 mm can be reached only with workpiece Ø ≤ 25 mm.

P	-	•
M	•	•
K	-	•
N	-	•
S	•	•
H	-	-

HM-Sorten
Carbide grades

F

Abstechen

Parting Off



Wendeschneidplatte

Indexable insert

S274

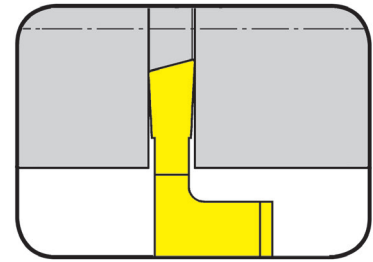

Stechtiefe bis Stechbreite	Depth of groove up to Width of groove	6 mm 0,8-2 mm
----------------------------	---------------------------------------	------------------

präzisionsgeschliffen
precision ground

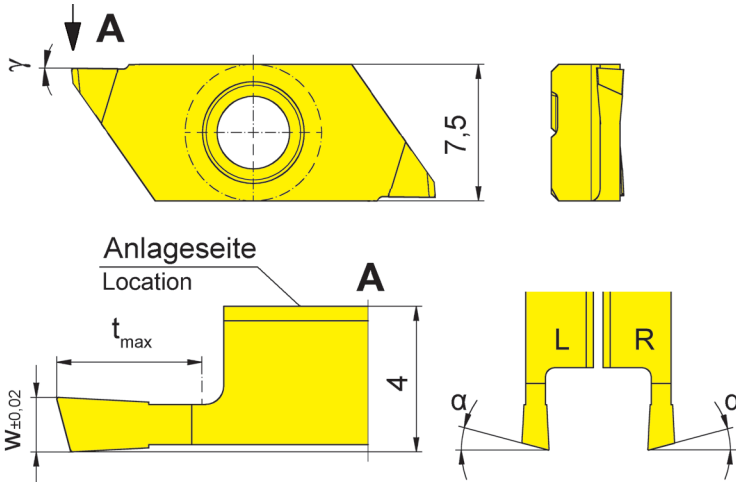

R = rechts wie gezeichnet
R = right hand version shown

L = links spiegelbildlich
L = left hand version

für Klemmhalter
for Toolholder

Typ H274
Type KT274
KTC274
974
76
H274KM
HC274KM

Wechselgenauigkeit
Länge ± 0,015 mm
Indexability length
± 0,015 mm

Bestellnummer Part number	w	t _{max}	α	γ	Größe Size	IG35	TH35
R/LS274.1508.03.M0	0,8	3	15°	0°	04	Δ/Δ	Δ/Δ
R/LS274.1510.03.M0	1,0	3	15°	0°	04	Δ/Δ	▲/Δ
R/LS274.1515.04.M0	1,5	4	15°	0°	04	Δ/Δ	Δ/Δ
R/LS274.1520.06.M0	2,0	6	15°	0°	04	Δ/Δ	Δ/Δ

▲ ab Lager / on stock Δ 4 Wochen / 4 weeks x auf Anfrage / upon request

● empfohlen / recommended

o bedingt einsetzbar / alternative recommendation

- nicht geeignet / not suitable

□ unbeschichtete HM-Sorten / uncoated grades

■ beschichtete HM-Sorten / coated grades

■ bestückt/Cermet / brazed/Cermet

Abmessungen in mm

Dimensions in mm

Ausführung R oder L angeben

State R or L version

Hinweis:

t_{max} 6 mm nur bei Werkstück-Ø ≤ 25 mm erreichbar.

Note:

t_{max} 6 mm can be reached only with workpiece Ø ≤ 25 mm.

P	-	•
M	•	•
K	-	•
N	-	•
S	•	•
H	-	-

HM-Sorten
Carbide grades



Abstechen

Parting Off



Wendeschneidplatte

Indexable insert

S274

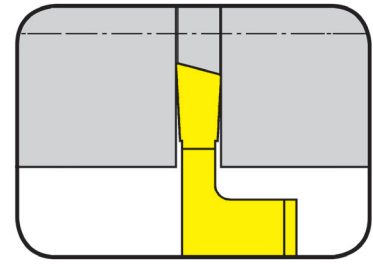

Stechtiefe bis Stechbreite	Depth of groove up to Width of groove	6 mm 0,8-2 mm
-------------------------------	--	------------------

präzisionsgeschliffen
precision ground

für Klemhalter
for Toolholder

Typ H274
Type KT274
KTC274
974
76
H274KM
HC274KM

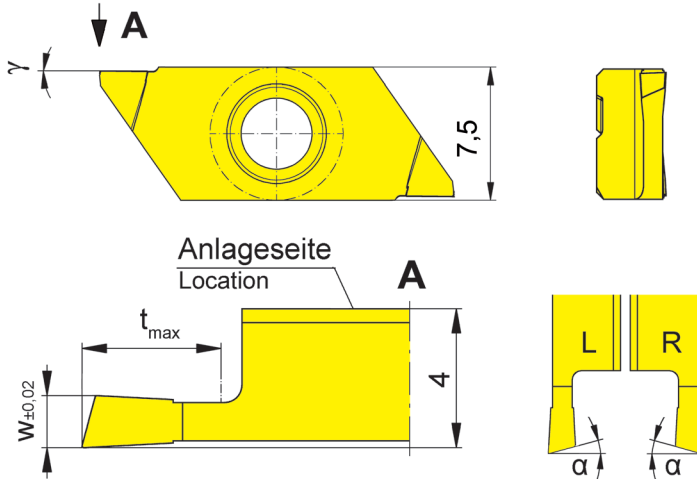

R = rechts wie gezeichnet
R = right hand version shown

L = links spiegelbildlich
L = left hand version

Wechselgenauigkeit
Länge $\pm 0,015$ mm
Indexability length
 $\pm 0,015$ mm

F

Bestellnummer Part number	w	t _{max}	α	γ	Größe Size	IG35	TH35
LS274.1508.03.M0R	0,8	3	15°	0°	04	Δ	▲
LS274.1510.03.M0R	1,0	3	15°	0°	04	Δ	Δ
LS274.1515.04.M0R	1,5	4	15°	0°	04	Δ	Δ
LS274.1520.06.M0R	2,0	6	15°	0°	04	Δ	Δ
RS274.1508.03.M0L	0,8	3	15°	0°	04	Δ	Δ
RS274.1510.03.M0L	1,0	3	15°	0°	04	Δ	Δ
RS274.1515.04.M0L	1,5	4	15°	0°	04	Δ	Δ
RS274.1520.06.M0L	2,0	6	15°	0°	04	Δ	Δ

- ▲ ab Lager / on stock Δ 4 Wochen / 4 weeks x auf Anfrage / upon request
- empfohlen / recommended
- o bedingt einsetzbar / alternative recommendation
- nicht geeignet / not suitable
- unbeschichtete HM-Sorten / uncoated grades
- beschichtete HM-Sorten / coated grades
- bestückt/Cermet / brazed/Cermet

Abmessungen in mm
Dimensions in mm

Hinweis:

t_{max} 6 mm nur bei Werkstück-Ø ≤ 25 mm erreichbar.

Note:

t_{max} 6 mm can be reached only with workpiece Ø ≤ 25 mm.

P	-	●
M	●	●
K	-	●
N	-	●
S	●	●
H	-	-

HM-Sorten
Carbide grades

Gewindedrehen (außen) Teilprofil

Threading (external) Partial profile



Wendeschneidplatte

Indexable insert

S274

Metrisches ISO-Gewinde
Metric ISO thread

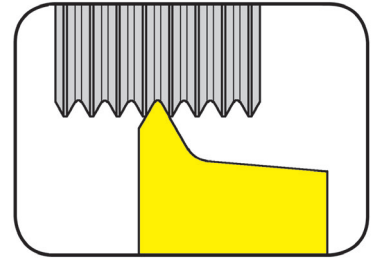

Steigung	Pitch	0,25-0,4 mm
----------	-------	-------------

präzisionsgeschliffen
precision ground

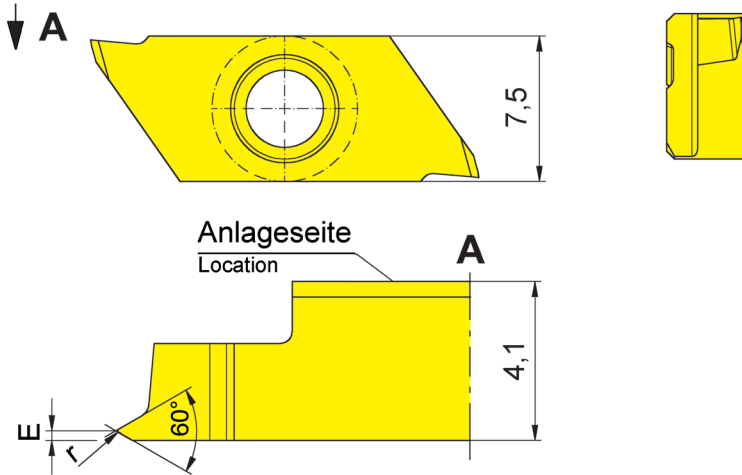

für Klemhalter
for Toolholder

Typ H274
Type KT274
KTC274
974
76
H274KM
HC274KM

Wechselgenauigkeit
Länge ± 0,015 mm
Indexability length
± 0,015 mm

R = rechts wie gezeichnet
R = right hand version shown

Bestellnummer Part number	P	E	r	Größe Size	IG35	TH35
RS274.0102.01	0,25	0,20	0,04	04	▲	▲
RS274.0203.01	0,35	0,25	0,05	04	▲	▲
RS274.0204.01	0,40	0,30	0,06	04	▲	▲
					P	•
					M	•
					K	•
					N	•
					S	•
					H	-

▲ ab Lager / on stock Δ 4 Wochen / 4 weeks x auf Anfrage / upon request

● empfohlen / recommended

o bedingt einsetzbar / alternative recommendation

- nicht geeignet / not suitable

■ unbeschichtete HM-Sorten / uncoated grades

■ beschichtete HM-Sorten / coated grades

■ bestückt/Cermet / brazed/Cermet

Abmessungen in mm

Dimensions in mm

Keine Unterlegplatte erforderlich. Sämtliche HORN-Gewindeprofile sind mit einem **KEGELMANTEL-FREISCHLIFF** versehen.

No shims necessary. All HORN thread profiles are manufactured with **full ground radial clearance**.

HM-Sorten
Carbide grades



Gewindedrehen (außen) Vollprofil

Threading (external) Full profile



Wendeschneidplatte

Indexable insert

S274

Metrisches ISO-Gewinde
Metric ISO thread

Steigung	Pitch	0,5-1,5 mm
----------	-------	------------

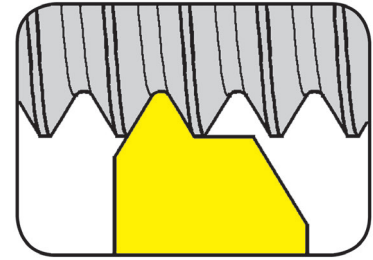

präzisionsgeschliffen
precision ground

für Klemhalter
for Toolholder

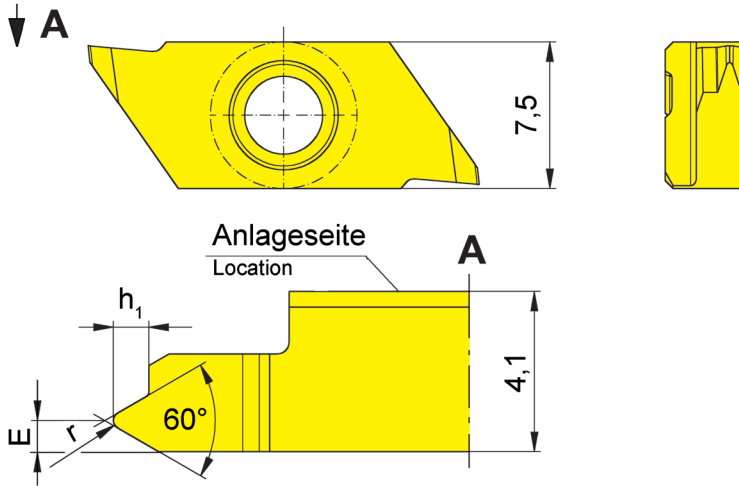

Typ H274
Type KT274
KTC274
974
76
H274KM
HC274KM

Wechselgenauigkeit
Länge $\pm 0,015$ mm
Indexability length
 $\pm 0,015$ mm

R = rechts wie gezeichnet
R = right hand version shown

L = links spiegelbildlich
L = left hand version

Bestellnummer Part number	P	E	r	h_1	Größe Size	IG35	TH35
R/LS274.0305.02	0,50	0,40	0,07	0,31	04	▲/▲	▲/▲
R/LS274.0306.02	0,60	0,45	0,09	0,37	04	△/△	▲/△
R/LS274.0307.02	0,70	0,50	0,10	0,43	04	▲/△	▲/△
R/LS274.0407.02	0,75	0,50	0,11	0,46	04	▲/△	▲/△
R/LS274.0408.02	0,80	0,55	0,12	0,49	04	▲/△	▲/△
R/LS274.0610.02	1,00	0,60	0,14	0,61	04	▲/△	▲/▲
R/LS274.0712.02	1,25	0,70	0,15	0,77	04	▲/▲	▲/▲
R/LS274.0915.02	1,50	0,80	0,20	0,92	04	▲/△	▲/△

▲ ab Lager / on stock △ 4 Wochen / 4 weeks x auf Anfrage / upon request

● empfohlen / recommended

o bedingt einsetzbar / alternative recommendation

- nicht geeignet / not suitable

■ unbeschichtete HM-Sorten / uncoated grades

■ beschichtete HM-Sorten / coated grades

■ bestückt/Cermet / brazed/Cermet

Abmessungen in mm

Dimensions in mm

Ausführung R oder L angeben

State R or L version

Keine Unterlegplatte erforderlich. Sämtliche HORN-Gewindeprofile sind mit einem **KEGELMANTEL-FREISCHLIFF** versehen.

No shims necessary. All HORN thread profiles are manufactured with **full ground radial clearance**.

P	-	•
M	•	•
K	-	•
N	-	•
S	•	•
H	-	-

HM-Sorten
Carbide grades

Gewindedrehen (außen) Vollprofil

Threading (external) Full profile



Wendeschneidplatte

Indexable insert

S274

Metrisches ISO-Gewinde
Metric ISO thread

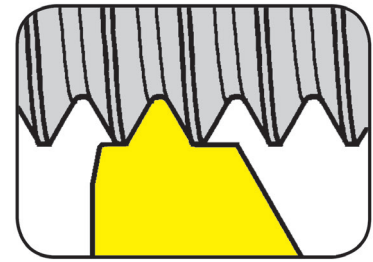

Steigung	Pitch	0,5-1,5 mm
----------	-------	------------

präzisionsgeschliffen
precision ground

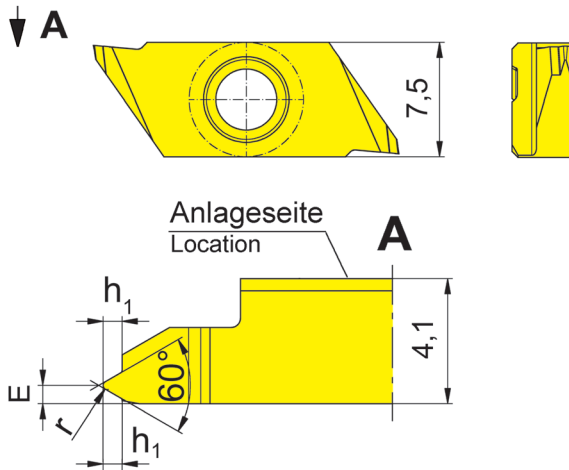

für Klemmhalter
for Toolholder

Typ H274
Type KT274
KTC274
974
76
H274KM
HC274KM

Wechselgenauigkeit
Länge ± 0,015 mm
Indexability length
± 0,015 mm

R = rechts wie gezeichnet
R = right hand version shown

L = links spiegelbildlich
L = left hand version

Bestellnummer Part number	P	E	r	h ₁	Größe Size	IG35	TH35
R/LS274.0305.03	0,50	0,40	0,07	0,31	04	Δ/Δ	▲/▲
R/LS274.0306.03	0,60	0,45	0,09	0,37	04	Δ/Δ	Δ/Δ
R/LS274.0307.03	0,70	0,50	0,10	0,43	04	Δ/Δ	▲/Δ
R/LS274.0407.03	0,75	0,50	0,11	0,46	04	Δ/Δ	Δ/Δ
R/LS274.0408.03	0,80	0,55	0,12	0,49	04	Δ/Δ	Δ/Δ
R/LS274.0610.03	1,00	0,60	0,14	0,61	04	▲/Δ	▲/Δ
R/LS274.0712.03	1,25	0,70	0,15	0,77	04	Δ/Δ	Δ/Δ
R/LS274.0915.03	1,50	0,80	0,20	0,92	04	Δ/Δ	▲/Δ

▲ ab Lager / on stock Δ 4 Wochen / 4 weeks x auf Anfrage / upon request

● empfohlen / recommended

o bedingt einsetzbar / alternative recommendation

- nicht geeignet / not suitable

■ unbeschichtete HM-Sorten / uncoated grades

■ beschichtete HM-Sorten / coated grades

■ bestückt/Cermet / brazed/Cermet

Abmessungen in mm

Dimensions in mm

Ausführung R oder L angeben

State R or L version

Keine Unterlegplatte erforderlich. Sämtliche HORN-Gewindeprofile sind mit einem **KEGELMANTEL-FREISCHLIFF** versehen.

No shims necessary. All HORN thread profiles are manufactured with **full ground radial clearance**.

P	-	●
M	●	●
K	-	●
N	-	●
S	●	●
H	-	-

HM-Sorten
Carbide grades



Einstecken und Drehen

Grooving and Turning



Klemmhalter

Toolholder

H274...E

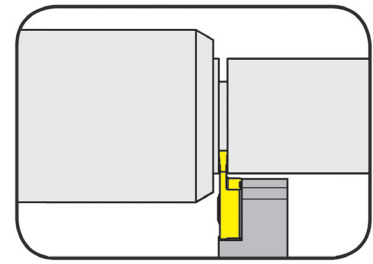

Stechtiefe	Depth of groove	6 mm
Stechbreite	Width of groove	0,5-3 mm

für Wendeschneidplatte
for Indexable insert

Typ S274...E
Type

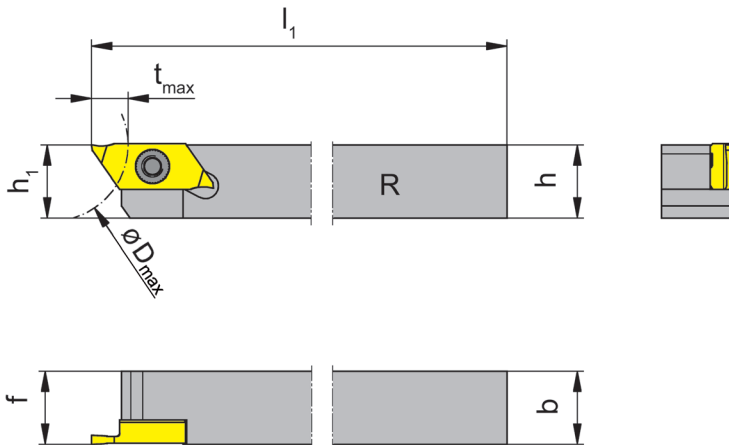

R = rechts wie gezeichnet
R = right hand version shown

L = links spiegelbildlich
L = left hand version

Bestellnummer Part number	h	b	l ₁	h ₁	f	t _{max}	D _{max}	Größe Size
R/LH274.1010.04.E	10	10	100	10	10	6	25	04
R/LH274.1212.04.E	12	12	100	12	12	6	25	04
R/LH274.1616.04.E	16	16	125	16	16	6	25	04

Ausführung R oder L angeben
State R or L version

Abmessungen in mm
Dimensions in mm

Weitere Abmessungen auf Anfrage
Further sizes upon request

Das Anzugsdrehmoment der Schrauben finden Sie in den Technischen Hinweisen.
For torque specification of the screw, please see Technical Instructions.

Ersatzteile

Spare Parts

Klemmhalter Toolholder	Spannschraube Clamping Screw	TORX PLUS®-Schlüssel TORX PLUS® Wrench
R/LH274...	030.3509.T15P	T15PQ

Einstecken und Längsdrehen

Grooving and Side Turning



Wendeschneidplatte

Indexable insert

S274...E

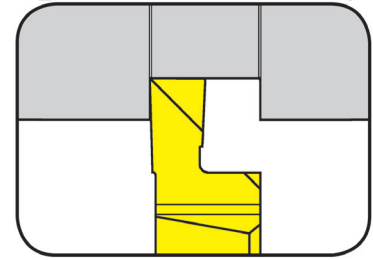

Stechtiefe bis Stechbreite	Depth of groove up to Width of groove	4,5 mm 1,5-3 mm
-------------------------------	--	--------------------

präzisionsgeschliffen
precision ground

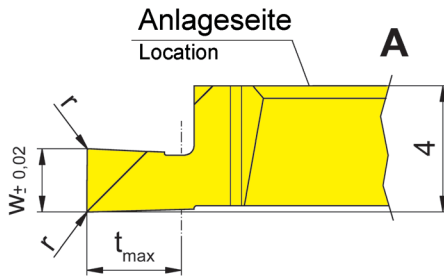
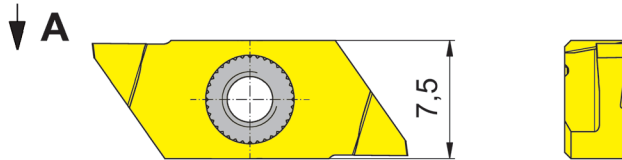

für Klemhalter
for Toolholder

Typ H274...E
Type

R = rechts wie gezeichnet
R = right hand version shown

L = links spiegelbildlich
L = left hand version

Wechselgenauigkeit
Länge ± 0,015 mm
Indexability length
± 0,015 mm

Bestellnummer Part number	w	r	t _{max}	Größe Size	IG35	TH35
R/LS274.0150.P0.E	1,5	0,05	2,25	04	ΔΔ	ΔΔ
R/LS274.0200.P0.E	2,0	0,05	3,00	04	ΔΔ	ΔΔ
R/LS274.0250.P0.E	2,5	0,10	3,75	04	ΔΔ	ΔΔ
R/LS274.0300.P0.E	3,0	0,10	4,50	04	ΔΔ	ΔΔ

▲ ab Lager / on stock Δ 4 Wochen / 4 weeks x auf Anfrage / upon request

● empfohlen / recommended

o bedingt einsetzbar / alternative recommendation

- nicht geeignet / not suitable

■ unbeschichtete HM-Sorten / uncoated grades

■ beschichtete HM-Sorten / coated grades

■ bestückt/Cermet / brazed/Cermet

Abmessungen in mm

Dimensions in mm

Ausführung R oder L angeben

State R or L version

P	-	•
M	•	•
K	-	•
N	-	•
S	•	•
H	-	-

HM-Sorten
Carbide grades



Einstecken und Längsdrehen

Grooving and Side Turning



Wendeschneidplatte

Indexable insert

S274...E

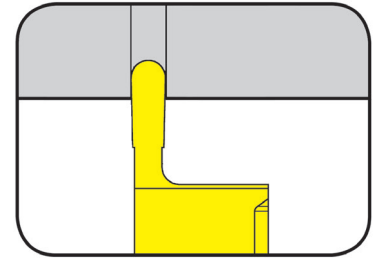

Stechtiefe bis Vollradius	Depth of groove up to Full radius	4 mm 0,25-1 mm
---------------------------	-----------------------------------	-------------------

präzisionsgeschliffen
precision ground

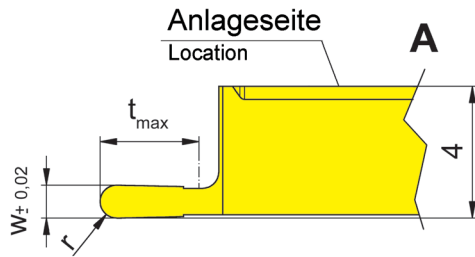
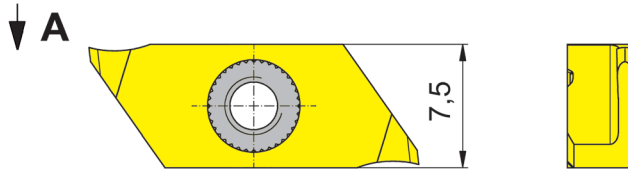

für Klemhalter
for Toolholder

Typ H274...E
Type

R = rechts wie gezeichnet
R = right hand version shown

L = links spiegelbildlich
L = left hand version

Wechselgenauigkeit
Länge ± 0,015 mm
Indexability length
± 0,015 mm

F

Bestellnummer Part number	w	t _{max}	r	Größe Size	IG35	TH35
R/LS274.0205.01.10.E	0,5	1,5	0,25	04	Δ/Δ	Δ/Δ
R/LS274.0510.03.10.E	1,0	3,0	0,50	04	Δ/Δ	▲/Δ
R/LS274.1020.04.10.E	2,0	4,0	1,00	04	Δ/Δ	Δ/Δ

▲ ab Lager / on stock Δ 4 Wochen / 4 weeks x auf Anfrage / upon request

● empfohlen / recommended

o bedingt einsetzbar / alternative recommendation

- nicht geeignet / not suitable

■ unbeschichtete HM-Sorten / uncoated grades

■ beschichtete HM-Sorten / coated grades

■ bestückt/Cermet / brazed/Cermet

Abmessungen in mm

Dimensions in mm

Ausführung R oder L angeben

State R or L version

P	-	•
M	•	•
K	-	•
N	-	•
S	•	•
H	-	-

HM-Sorten
Carbide grades

Einstechen und Abstechen

Grooving and Parting Off



Wendeschneidplatte

Indexable insert

S274...E

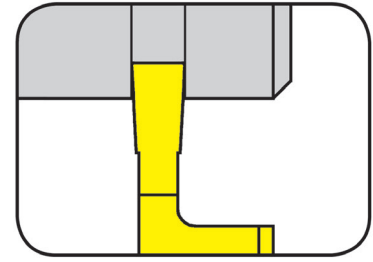

Stechtiefe bis Stechbreite	Depth of groove up to Width of groove	6 mm 0,5-2 mm
-------------------------------	--	------------------

präzisionsgeschliffen
precision ground

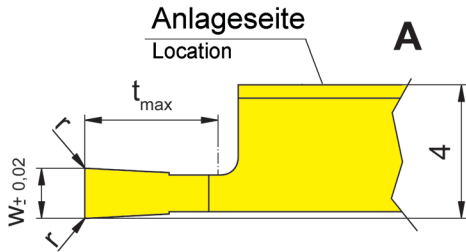
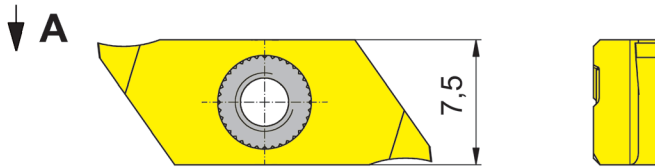

für Klemhalter
for Toolholder

Typ H274...E
Type

R = rechts wie gezeichnet
R = right hand version shown

L = links spiegelbildlich
L = left hand version

Wechselgenauigkeit
Länge ± 0,015 mm
Indexability length
± 0,015 mm

Bestellnummer Part number	w	r	t _{max}	Größe Size	IG35	TH35
R/LS274.0050.01.10.E	0,5	0,05	1,5	04	ΔΔ	ΔΔ
R/LS274.0070.02.10.E	0,7	0,05	2,0	04	ΔΔ	ΔΔ
R/LS274.0080.03.10.E	0,8	0,05	3,0	04	ΔΔ	ΔΔ
R/LS274.0100.03.10.E	1,0	0,05	3,0	04	Δx	ΔΔ
R/LS274.0120.03.10.E	1,2	0,05	3,0	04	ΔΔ	ΔΔ
R/LS274.0150.04.10.E	1,5	0,05	4,0	04	ΔΔ	ΔΔ
R/LS274.0150.06.10.E	1,5	0,05	6,0	04	ΔΔ	ΔΔ
R/LS274.0200.04.10.E	2,0	0,05	4,0	04	ΔΔ	ΔΔ
R/LS274.0200.06.10.E	2,0	0,05	6,0	04	ΔΔ	ΔΔ

▲ ab Lager / on stock Δ 4 Wochen / 4 weeks x auf Anfrage / upon request

● empfohlen / recommended

o bedingt einsetzbar / alternative recommendation

- nicht geeignet / not suitable

■ unbeschichtete HM-Sorten / uncoated grades

■ beschichtete HM-Sorten / coated grades

■ bestückt/Cermet / brazed/Cermet

Abmessungen in mm

Dimensions in mm

Ausführung R oder L angeben

State R or L version

P	-	•
M	•	•
K	-	•
N	-	•
S	•	•
H	-	-

HM-Sorten
Carbide grades



Einstechen und Abstechen

Grooving and Parting Off



Wendeschneidplatte

Indexable insert

S274...E

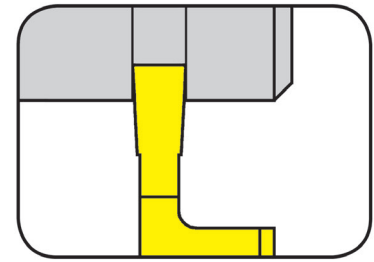

Stechtiefe bis Stechbreite	Depth of groove up to Width of groove	6 mm 0,5-2 mm
-------------------------------	--	------------------

präzisionsgeschliffen
precision ground

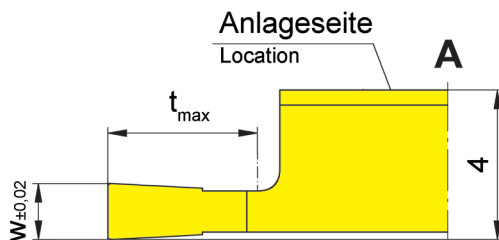
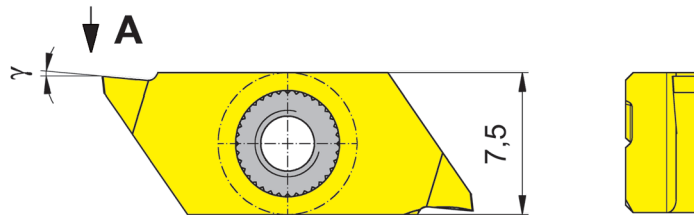

für Klemhalter
for Toolholder

Typ H274...E
Type

R = rechts wie gezeichnet
R = right hand version shown

L = links spiegelbildlich
L = left hand version

Wechselgenauigkeit
Länge ± 0,015 mm
Indexability length
± 0,015 mm

F

Bestellnummer Part number	w	t _{max}	γ	Größe Size	IG35	TH35
R/LS274.0050.01.20.E	0,5	1,5	5°	04	ΔΔ	ΔΔ
R/LS274.0070.02.20.E	0,7	2,0	5°	04	ΔΔ	ΔΔ
R/LS274.0080.03.20.E	0,8	3,0	5°	04	ΔΔ	ΔΔ
R/LS274.0100.03.20.E	1,0	3,0	5°	04	ΔΔ	ΔΔ
R/LS274.0120.03.20.E	1,2	3,0	5°	04	ΔΔ	ΔΔ
R/LS274.0150.04.20.E	1,5	4,0	5°	04	ΔΔ	ΔΔ
R/LS274.0150.06.20.E	1,5	6,0	5°	04	ΔΔ	ΔΔ
R/LS274.0200.04.20.E	2,0	4,0	5°	04	ΔΔ	ΔΔ
R/LS274.0200.06.20.E	2,0	6,0	5°	04	ΔΔ	ΔΔ

▲ ab Lager / on stock Δ 4 Wochen / 4 weeks x auf Anfrage / upon request

● empfohlen / recommended

o bedingt einsetzbar / alternative recommendation

- nicht geeignet / not suitable

■ unbeschichtete HM-Sorten / uncoated grades

■ beschichtete HM-Sorten / coated grades

■ bestückt/Cermet / brazed/Cermet

Abmessungen in mm

Dimensions in mm

Ausführung R oder L angeben

State R or L version

P	-	•
M	•	•
K	-	•
N	-	•
S	•	•
H	-	-

HM-Sorten
Carbide grades

Einstechen und Abstechen

Grooving and Parting Off



Wendeschneidplatte

Indexable insert

S274...E

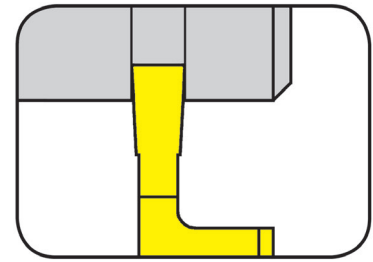

Stechtiefe bis Stechbreite	Depth of groove up to Width of groove	6 mm 0,5-2 mm
-------------------------------	--	------------------

präzisionsgeschliffen
precision ground

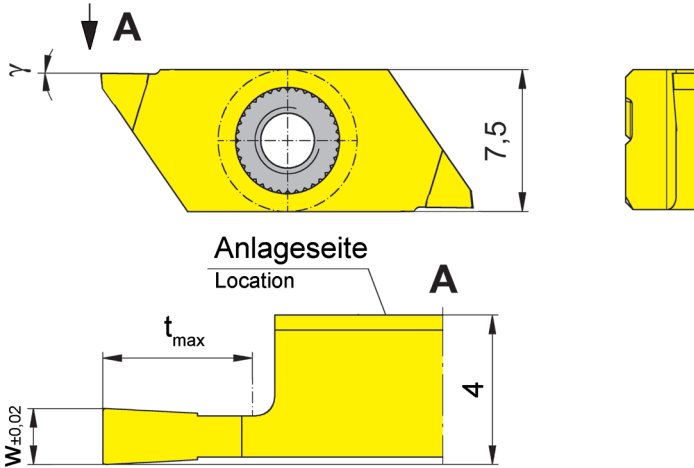

für Klemhalter
for Toolholder

Typ H274...E
Type

R = rechts wie gezeichnet
R = right hand version shown

L = links spiegelbildlich
L = left hand version

Wechselgenauigkeit
Länge ± 0,015 mm
Indexability length
± 0,015 mm

Bestellnummer Part number	w	t _{max}	γ	Größe Size	IG35	TH35
R/LS274.0050.01.M0.E	0,5	1,5	0°	04	ΔΔ	ΔΔ
R/LS274.0070.02.M0.E	0,7	2,0	0°	04	ΔΔ	ΔΔ
R/LS274.0080.03.M0.E	0,8	3,0	0°	04	ΔΔ	ΔΔ
R/LS274.0100.03.M0.E	1,0	3,0	0°	04	ΔΔ	ΔΔ
R/LS274.0120.03.M0.E	1,2	3,0	0°	04	ΔΔ	ΔΔ
R/LS274.0150.04.M0.E	1,5	4,0	0°	04	ΔΔ	ΔΔ
R/LS274.0150.06.M0.E	1,5	6,0	0°	04	ΔΔ	ΔΔ
R/LS274.0200.04.M0.E	2,0	4,0	0°	04	ΔΔ	ΔΔ
R/LS274.0200.06.M0.E	2,0	6,0	0°	04	ΔΔ	ΔΔ

▲ ab Lager / on stock Δ 4 Wochen / 4 weeks x auf Anfrage / upon request

● empfohlen / recommended

o bedingt einsetzbar / alternative recommendation

- nicht geeignet / not suitable

■ unbeschichtete HM-Sorten / uncoated grades

■ beschichtete HM-Sorten / coated grades

■ bestückt/Cermet / brazed/Cermet

Abmessungen in mm

Dimensions in mm

Ausführung R oder L angeben

State R or L version

P	-	•
M	•	•
K	-	•
N	-	•
S	•	•
H	-	-

HM-Sorten
Carbide grades



Rückwärtsdrehen (außen)

Backturning (external)



Wendeschneidplatte

Indexable insert

S274...E

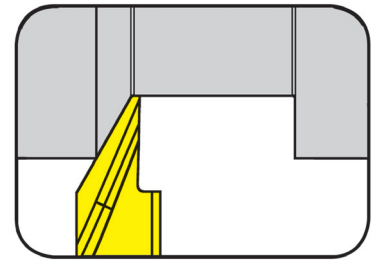

Schnitttiefe bis	Depth of cut up to	6 mm
------------------	--------------------	------

präzisionsgeschliffen
precision ground

für Klemhalter
for Toolholder

Typ H274...E
Type

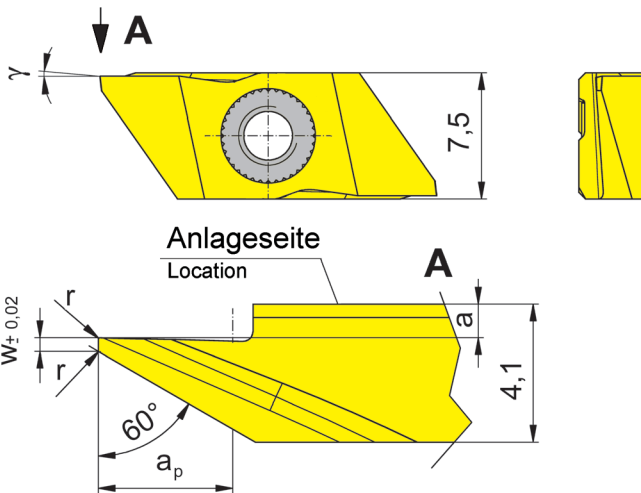

R = rechts wie gezeichnet
R = right hand version shown

L = links spiegelbildlich
L = left hand version

Wechselgenauigkeit
Länge ± 0,015 mm
Indexability length
± 0,015 mm

Bestellnummer Part number	w	r	a	γ	a _p	Größe Size	K10	IG35	TH35
R/LS274.0060.04.10.E	-	0,05	1,00	15°	4	04		Δ/Δ	Δ/Δ
R/LS274.0460.04.10.E	0,4	0,05	1,00	15°	4	04		Δ/Δ	▲/Δ
R/LS274.0460.04.M0.E	0,4	0,05	1,00	0°	4	04	Δ/Δ	Δ/Δ	Δ/Δ
R/LS274.0560.06.11.E	0,5	0,10	0,05	15°	6	04		Δ/Δ	▲/Δ

▲ ab Lager / on stock Δ 4 Wochen / 4 weeks x auf Anfrage / upon request

● empfohlen / recommended

o bedingt einsetzbar / alternative recommendation

- nicht geeignet / not suitable

□ unbeschichtete HM-Sorten / uncoated grades

■ beschichtete HM-Sorten / coated grades

■ bestückt/Cermet / brazed/Cermet

Abmessungen in mm

Dimensions in mm

Ausführung R oder L angeben

State R or L version

P	●	-	●
M	○	●	●
K	●	-	●
N	●	-	●
S	○	●	●
H	-	-	-

HM-Sorten
Carbide grades

F

Längsdrehen

Side Turning



Wendeschneidplatte

Indexable insert

S274...E

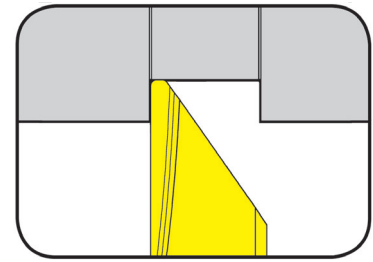

Schnitttiefe bis	Depth of cut up to	6 mm
------------------	--------------------	------

präzisionsgeschliffen
precision ground

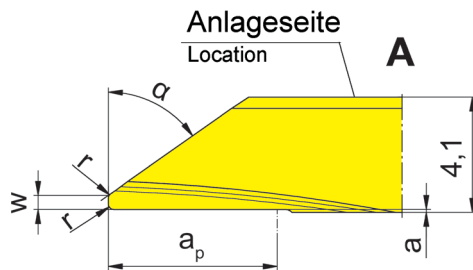
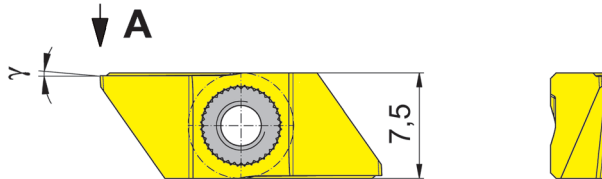

für Klemhalter
for Toolholder

Typ H274...E
Type

R = rechts wie gezeichnet
R = right hand version shown

L = links spiegelbildlich
L = left hand version

Wechselgenauigkeit
Länge ± 0,015 mm
Indexability length
± 0,015 mm

Bestellnummer Part number	w	r	a	γ	a _p	α	Größe Size	IG35	TH35
R/LS274.0035.04.20.E	-	0,05	0,1	5°	4	35°	04	ΔΔ	ΔΔ
R/LS274.0235.04.20.E	0,2	-	0,1	5°	4	35°	04	ΔΔ	ΔΔ
R/LS274.0535.06.20.E	0,5	0,20	0,1	5°	6	35°	04	ΔΔ	ΔΔ
R/LS274.0055.04.20.E	-	0,05	0,1	5°	4	55°	04	ΔΔ	ΔΔ
R/LS274.0255.04.20.E	0,2	-	0,1	5°	4	55°	04	ΔΔ	ΔΔ
R/LS274.0555.06.20.E	0,5	0,20	0,1	5°	6	55°	04	ΔΔ	ΔΔ

▲ ab Lager / on stock Δ 4 Wochen / 4 weeks x auf Anfrage / upon request

● empfohlen / recommended

o bedingt einsetzbar / alternative recommendation

- nicht geeignet / not suitable

□ unbeschichtete HM-Sorten / uncoated grades

■ beschichtete HM-Sorten / coated grades

■ bestückt/Cermet / brazed/Cermet

Abmessungen in mm

Dimensions in mm

Ausführung R oder L angeben

State R or L version

P	-	•
M	•	•
K	-	•
N	-	•
S	•	•
H	-	-

HM-Sorten
Carbide grades



Abstechen

Parting Off



Wendeschneidplatte

Indexable insert

S274...E

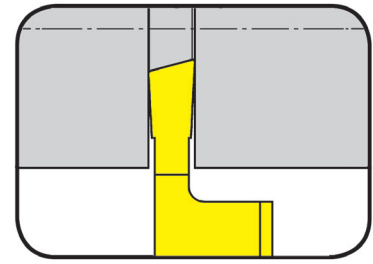

Stechtiefe bis Stechbreite	Depth of groove up to Width of groove	6 mm 0,8-2 mm
-------------------------------	--	------------------

präzisionsgeschliffen
precision ground

für Klemhalter
for Toolholder

Typ H274...E
Type

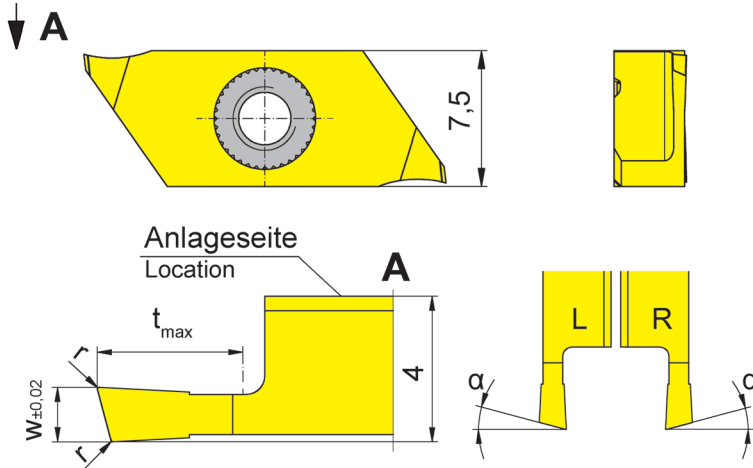

R = rechts wie gezeichnet
R = right hand version shown

L = links spiegelbildlich
L = left hand version

Wechselgenauigkeit
Länge $\pm 0,015$ mm
Indexability length
 $\pm 0,015$ mm

Bestellnummer Part number	w	r	t_{max}	α	Größe Size	IG35	TH35
R/LS274.1508.03.10.E	0,8	0,05	3	15°	04	ΔΔ	ΔΔ
R/LS274.1510.03.10.E	1,0	0,05	3	15°	04	ΔΔ	ΔΔ
R/LS274.1515.04.10.E	1,5	0,05	4	15°	04	ΔΔ	ΔΔ
R/LS274.1520.06.10.E	2,0	0,05	6	15°	04	ΔΔ	ΔΔ

▲ ab Lager / on stock Δ 4 Wochen / 4 weeks x auf Anfrage / upon request

● empfohlen / recommended

o bedingt einsetzbar / alternative recommendation

- nicht geeignet / not suitable

■ unbeschichtete HM-Sorten / uncoated grades

■ beschichtete HM-Sorten / coated grades

■ bestückt/Cermet / brazed/Cermet

Abmessungen in mm

Dimensions in mm

Ausführung R oder L angeben

State R or L version

Hinweis:

t_{max} 6 mm nur bei Werkstück- $\varnothing \leq 25$ mm erreichbar.

Note:

t_{max} 6 mm can be reached only with workpiece $\varnothing \leq 25$ mm.

P	-	•
M	•	•
K	-	•
N	-	•
S	•	•
H	-	-

HM-Sorten
Carbide grades

F

Abstechen

Parting Off



Wendeschneidplatte

Indexable insert

S274...E

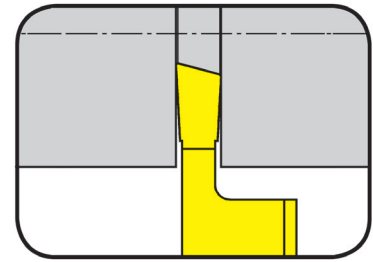

Stechtiefe bis Stechbreite	Depth of groove up to Width of groove	6 mm 0,8-2 mm
-------------------------------	--	------------------

präzisionsgeschliffen
precision ground

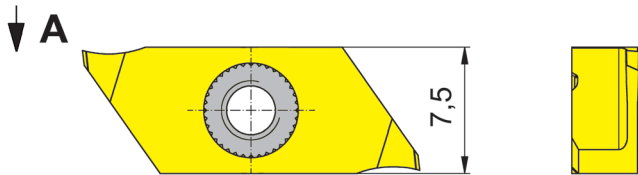

für Klemhalter
for Toolholder

Typ H274...E
Type

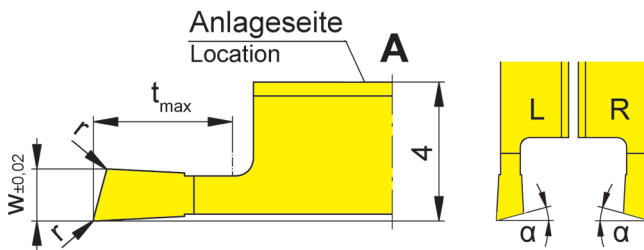

Wechselgenauigkeit
Länge ± 0,015 mm
Indexability length
± 0,015 mm

R = rechts wie gezeichnet
R = right hand version shown

L = links spiegelbildlich
L = left hand version

Bestellnummer Part number	w	r	t _{max}	α	Größe Size	IG35	TH35
LS274.1508.03.1R.E	0,8	0,05	3	15°	04	Δ	Δ
LS274.1510.03.1R.E	1,0	0,05	3	15°	04	Δ	Δ
LS274.1515.04.1R.E	1,5	0,05	4	15°	04	Δ	Δ
LS274.1520.06.1R.E	2,0	0,05	6	15°	04	Δ	Δ
RS274.1508.03.1L.E	0,8	0,05	3	15°	04	Δ	Δ
RS274.1510.03.1L.E	1,0	0,05	3	15°	04	Δ	Δ
RS274.1515.04.1L.E	1,5	0,05	4	15°	04	Δ	Δ
RS274.1520.06.1L.E	2,0	0,05	6	15°	04	Δ	Δ

- ▲ ab Lager / on stock Δ 4 Wochen / 4 weeks x auf Anfrage / upon request
- empfohlen / recommended
- o bedingt einsetzbar / alternative recommendation
- nicht geeignet / not suitable
- unbeschichtete HM-Sorten / uncoated grades
- beschichtete HM-Sorten / coated grades
- bestückt/Cermet / brazed/Cermet

Abmessungen in mm
Dimensions in mm

Hinweis:

t_{max} 6 mm nur bei Werkstück-Ø ≤ 25 mm erreichbar.

Note:

t_{max} 6 mm can be reached only with workpiece Ø ≤ 25 mm.

P	-	●
M	●	●
K	-	●
N	-	●
S	●	●
H	-	-

HM-Sorten
Carbide grades



Abstechen

Parting Off



Wendeschneidplatte

Indexable insert

S274...E

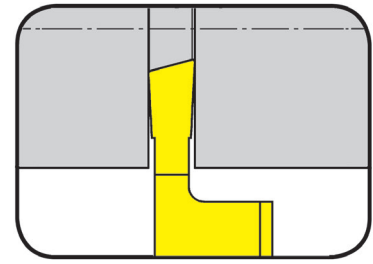

Stechtiefe bis Stechbreite	Depth of groove up to Width of groove	6 mm 1,5-2 mm
-------------------------------	--	------------------

präzisionsgeschliffen
precision ground

für Klemmhalter
for Toolholder

Typ H274...E
Type

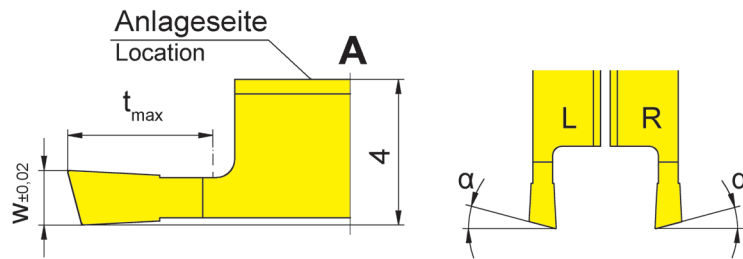
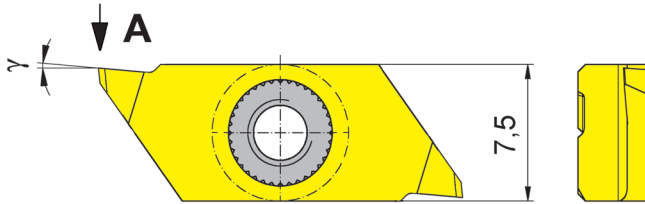

R = rechts wie gezeichnet
R = right hand version shown

L = links spiegelbildlich
L = left hand version

Wechselgenauigkeit
Länge ± 0,015 mm
Indexability length
± 0,015 mm

Bestellnummer Part number	w	t _{max}	α	γ	Größe Size	IG35	TH35
R/LS274.1515.04.20.E	1,5	4	15°	5°	04	Δ/Δ	Δ/Δ
R/LS274.1520.06.20.E	2,0	6	15°	5°	04	Δ/Δ	Δ/Δ

▲ ab Lager / on stock Δ 4 Wochen / 4 weeks x auf Anfrage / upon request

● empfohlen / recommended

o bedingt einsetzbar / alternative recommendation

- nicht geeignet / not suitable

■ unbeschichtete HM-Sorten / uncoated grades

■ beschichtete HM-Sorten / coated grades

■ bestückt/Cermet / brazed/Cermet

Abmessungen in mm

Dimensions in mm

Ausführung R oder L angeben

State R or L version

Hinweis:

t_{max} 6 mm nur bei Werkstück-Ø ≤ 25 mm erreichbar.

Note:

t_{max} 6 mm can be reached only with workpiece Ø ≤ 25 mm.

P	-	•
M	•	•
K	-	•
N	-	•
S	•	•
H	-	-

HM-Sorten
Carbide grades

F

Abstechen

Parting Off



Wendeschneidplatte

Indexable insert

S274...E

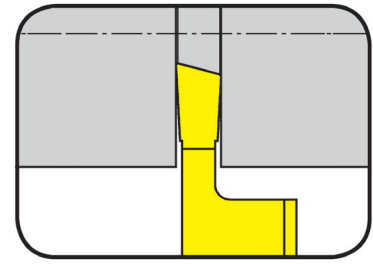

Stechtiefe bis Stechbreite	Depth of groove up to Width of groove	6 mm 1,5-2 mm
-------------------------------	--	------------------

präzisionsgeschliffen
precision ground

für Klemhalter
for Toolholder

Typ H274...E
Type

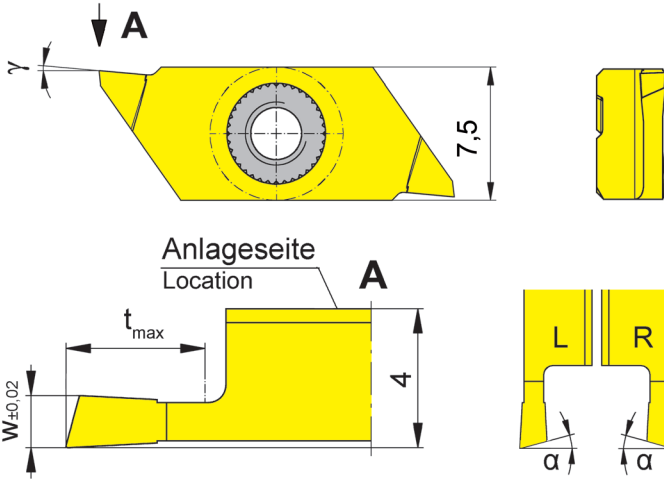

R = rechts wie gezeichnet
R = right hand version shown

L = links spiegelbildlich
L = left hand version

Wechselgenauigkeit
Länge ± 0,015 mm
Indexability length
± 0,015 mm

Bestellnummer Part number	w	t _{max}	α	γ	Größe Size	IG35	TH35
LS274.1515.04.2R.E	1,5	4	15°	5°	04	Δ	Δ
LS274.1520.06.2R.E	2,0	6	15°	5°	04	Δ	Δ
RS274.1515.04.2L.E	1,5	4	15°	5°	04	Δ	Δ
RS274.1520.06.2L.E	2,0	6	15°	5°	04	Δ	Δ

▲ ab Lager / on stock Δ 4 Wochen / 4 weeks x auf Anfrage / upon request

● empfohlen / recommended

o bedingt einsetzbar / alternative recommendation

- nicht geeignet / not suitable

□ unbeschichtete HM-Sorten / uncoated grades

■ beschichtete HM-Sorten / coated grades

■ bestückt/Cermet / brazed/Cermet

Abmessungen in mm

Dimensions in mm

Hinweis:

t_{max} 6 mm nur bei Werkstück-Ø ≤ 25 mm erreichbar.

Note:

t_{max} 6 mm can be reached only with workpiece Ø ≤ 25 mm.

P	-	•
M	•	•
K	-	•
N	-	•
S	•	•
H	-	-

HM-Sorten
Carbide grades



Abstechen

Parting Off



Wendeschneidplatte

Indexable insert

S274...E

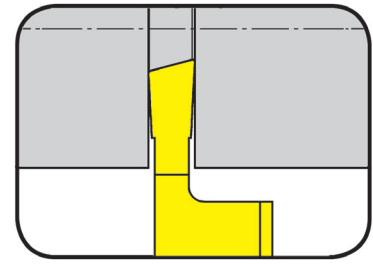

Stechtiefe bis Stechbreite	Depth of groove up to Width of groove	6 mm 0,8-2 mm
----------------------------	---------------------------------------	------------------

präzisionsgeschliffen
precision ground

für Klemmhalter
for Toolholder

Typ H274...E
Type

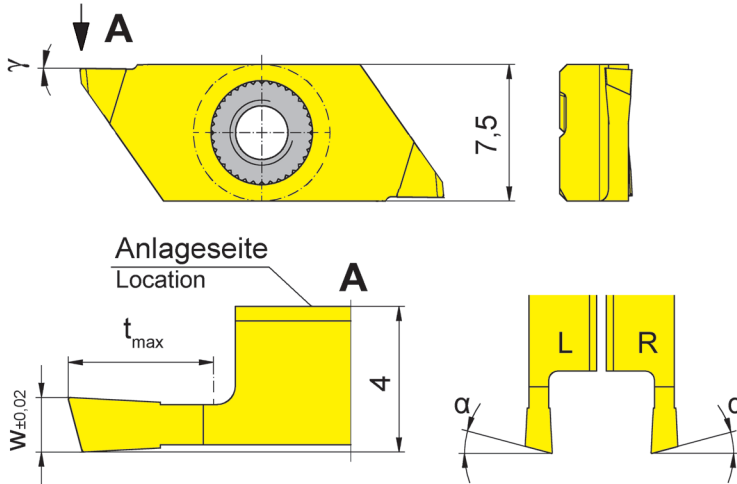

R = rechts wie gezeichnet
R = right hand version shown

L = links spiegelbildlich
L = left hand version

Wechselgenauigkeit
Länge ± 0,015 mm
Indexability length
± 0,015 mm

Bestellnummer Part number	w	t _{max}	α	γ	Größe Size	IG35	TH35
R/LS274.1508.03.M0.E	0,8	3	15°	0°	04	ΔΔ	ΔΔ
R/LS274.1510.03.M0.E	1,0	3	15°	0°	04	ΔΔ	ΔΔ
R/LS274.1515.04.M0.E	1,5	4	15°	0°	04	ΔΔ	ΔΔ
R/LS274.1520.06.M0.E	2,0	6	15°	0°	04	ΔΔ	ΔΔ

▲ ab Lager / on stock Δ 4 Wochen / 4 weeks x auf Anfrage / upon request

● empfohlen / recommended

o bedingt einsetzbar / alternative recommendation

- nicht geeignet / not suitable

■ unbeschichtete HM-Sorten / uncoated grades

■ beschichtete HM-Sorten / coated grades

■ bestückt/Cermet / brazed/Cermet

Abmessungen in mm

Dimensions in mm

Ausführung R oder L angeben

State R or L version

Hinweis:

t_{max} 6 mm nur bei Werkstück-Ø ≤ 25 mm erreichbar.

Note:

t_{max} 6 mm can be reached only with workpiece Ø ≤ 25 mm.

P	-	•
M	•	•
K	-	•
N	-	•
S	•	•
H	-	-

HM-Sorten
Carbide grades

F

Abstechen

Parting Off



Wendeschneidplatte

Indexable insert

S274...E

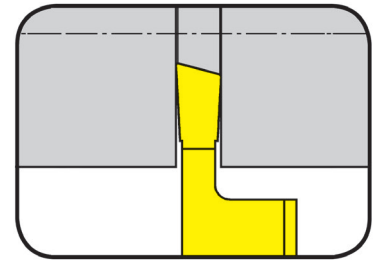

Stechtiefe bis Stechbreite	Depth of groove up to Width of groove	6 mm 0,8-2 mm
-------------------------------	--	------------------

präzisionsgeschliffen
precision ground

für Klemhalter
for Toolholder

Typ H274...E
Type

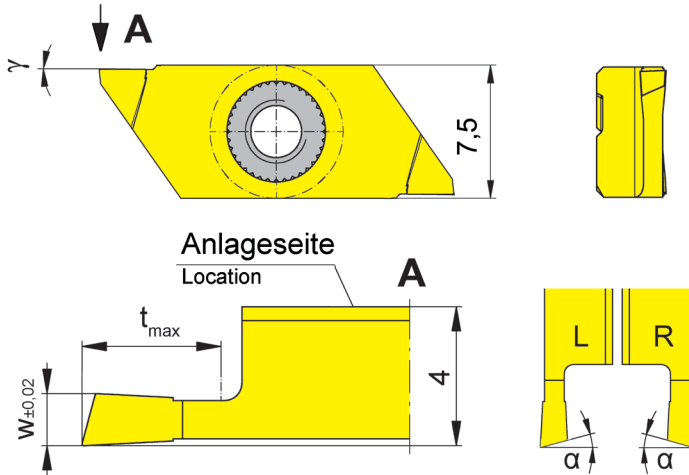

R = rechts wie gezeichnet
R = right hand version shown

L = links spiegelbildlich
L = left hand version

Wechselgenauigkeit
Länge ± 0,015 mm
Indexability length
± 0,015 mm

Bestellnummer Part number	w	t _{max}	α	γ	Größe Size	IG35	TH35
LS274.1508.03.MR.E	0,8	3	15°	0°	04	Δ	Δ
LS274.1510.03.MR.E	1,0	3	15°	0°	04	Δ	Δ
LS274.1515.04.MR.E	1,5	4	15°	0°	04	Δ	Δ
LS274.1520.06.MR.E	2,0	6	15°	0°	04	Δ	Δ
RS274.1508.03.ML.E	0,8	3	15°	0°	04	Δ	Δ
RS274.1510.03.ML.E	1,0	3	15°	0°	04	Δ	Δ
RS274.1515.04.ML.E	1,5	4	15°	0°	04	Δ	Δ
RS274.1520.06.ML.E	2,0	6	15°	0°	04	Δ	Δ

- ▲ ab Lager / on stock Δ 4 Wochen / 4 weeks x auf Anfrage / upon request
- empfohlen / recommended
- o bedingt einsetzbar / alternative recommendation
- nicht geeignet / not suitable
- unbeschichtete HM-Sorten / uncoated grades
- beschichtete HM-Sorten / coated grades
- bestückt/Cermet / brazed/Cermet

Abmessungen in mm
Dimensions in mm

Hinweis:

t_{max} 6 mm nur bei Werkstück-Ø ≤ 25 mm erreichbar.

Note:

t_{max} 6 mm can be reached only with workpiece Ø ≤ 25 mm.

P	-	●
M	●	●
K	-	●
N	-	●
S	●	●
H	-	-

HM-Sorten
Carbide grades



Gewindedrehen (außen) Teilprofil

Threading (external) Partial profile



Wendeschneidplatte

Indexable insert

S274

Metrisches ISO-Gewinde
Metric ISO thread

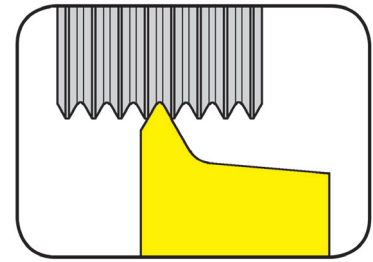

Steigung	Pitch	0,25-0,4 mm
----------	-------	-------------

präzisionsgeschliffen
precision ground

für Klemhalter
for Toolholder

Typ H274...E
Type

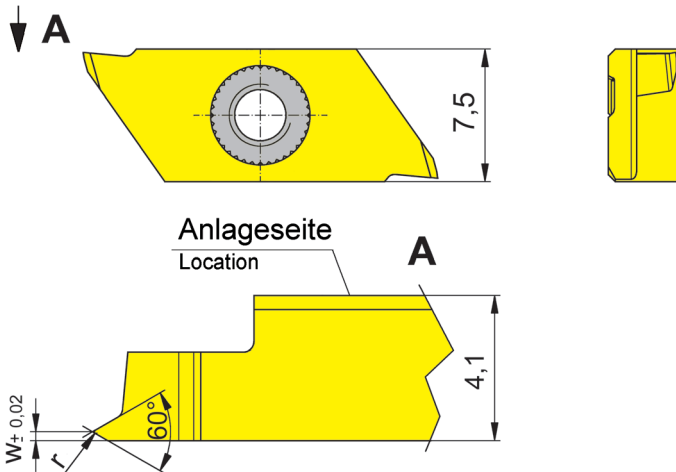

R = rechts wie gezeichnet
R = right hand version shown

Wechselgenauigkeit
Länge $\pm 0,015$ mm
Indexability length
 $\pm 0,015$ mm

Bestellnummer Part number	P	E	r	Größe Size	IG35	TH35
RS274.0102.01.E	0,25	0,20	0,04	04	Δ	Δ
RS274.0203.01.E	0,35	0,25	0,05	04	Δ	Δ
RS274.0204.01.E	0,40	0,30	0,06	04	Δ	Δ

	P	M	K	N	S	H
IG35	-	•	-	-	•	-
TH35	•	•	•	•	•	-

▲ ab Lager / on stock Δ 4 Wochen / 4 weeks x auf Anfrage / upon request

● empfohlen / recommended

o bedingt einsetzbar / alternative recommendation

- nicht geeignet / not suitable

□ unbeschichtete HM-Sorten / uncoated grades

■ beschichtete HM-Sorten / coated grades

■ bestückt/Cermet / brazed/Cermet

Abmessungen in mm

Dimensions in mm

HM-Sorten
Carbide grades

Keine Unterlegplatte erforderlich. Sämtliche HORN-Gewindeprofile sind mit einem **KEGELMANTEL-FREISCHLIFF** versehen.

No shims necessary. All HORN thread profiles are manufactured with **full ground radial clearance**.

F

Gewindedrehen (außen) Vollprofil

Threading (external) Full profile



Wendeschneidplatte

Indexable insert

S274

Metrisches ISO-Gewinde
Metric ISO thread

Steigung	Pitch	0,5-1,5 mm
----------	-------	------------

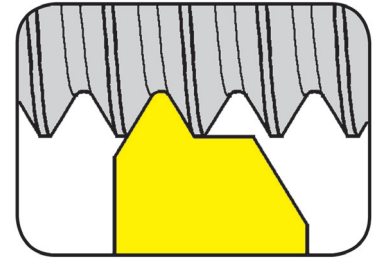

präzisionsgeschliffen
precision ground

für Klemmhalter
for Toolholder

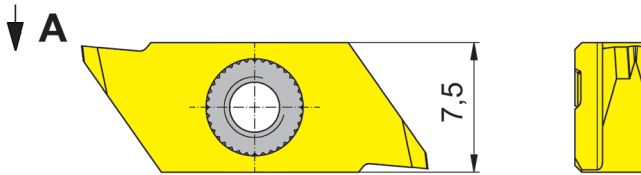

Typ H274...E
Type

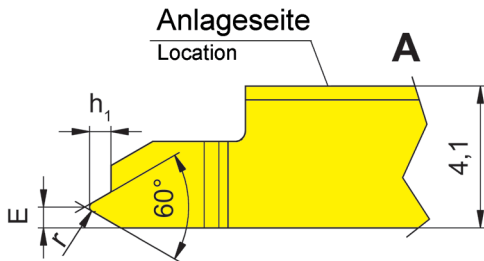

R = rechts wie gezeichnet
R = right hand version shown

L = links spiegelbildlich
L = left hand version

Wechselgenauigkeit
Länge ± 0,015 mm
Indexability length
± 0,015 mm

Bestellnummer Part number	P	E	r	h ₁	Größe Size	IG35	TH35
R/LS274.0305.02.E	0,50	0,40	0,07	0,31	04	ΔΔ	ΔΔ
R/LS274.0306.02.E	0,60	0,45	0,09	0,37	04	ΔΔ	ΔΔ
R/LS274.0307.02.E	0,70	0,50	0,10	0,43	04	ΔΔ	ΔΔ
R/LS274.0407.02.E	0,75	0,50	0,11	0,46	04	ΔΔ	ΔΔ
R/LS274.0408.02.E	0,80	0,55	0,12	0,49	04	ΔΔ	ΔΔ
R/LS274.0610.02.E	1,00	0,60	0,14	0,61	04	ΔΔ	ΔΔ
R/LS274.0712.02.E	1,25	0,70	0,15	0,77	04	ΔΔ	ΔΔ
R/LS274.0915.02.E	1,50	0,80	0,20	0,92	04	ΔΔ	ΔΔ

▲ ab Lager / on stock Δ 4 Wochen / 4 weeks x auf Anfrage / upon request

● empfohlen / recommended

o bedingt einsetzbar / alternative recommendation

- nicht geeignet / not suitable

■ unbeschichtete HM-Sorten / uncoated grades

■ beschichtete HM-Sorten / coated grades

■ bestückt/Cermet / brazed/Cermet

Abmessungen in mm

Dimensions in mm

Ausführung R oder L angeben

State R or L version

Keine Unterlegplatte erforderlich. Sämtliche HORN-Gewindeprofile sind mit einem **KEGELMANTEL-FREISCHLIFF** versehen.

No shims necessary. All HORN thread profiles are manufactured with **full ground radial clearance**.

P	-	●
M	●	●
K	-	●
N	-	●
S	●	●
H	-	-

HM-Sorten
Carbide grades



Gewindedrehen (außen) Vollprofil

Threading (external) Full profile



Wendeschneidplatte

Indexable insert

S274

Metrisches ISO-Gewinde
Metric ISO thread

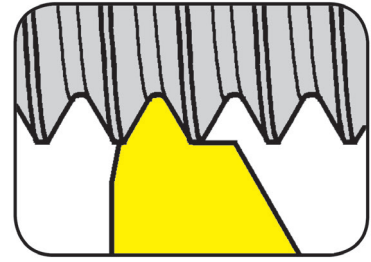

Steigung	Pitch	0,5-1,5 mm
----------	-------	------------

präzisionsgeschliffen
precision ground

für Klemhalter
for Toolholder

Typ H274...E
Type

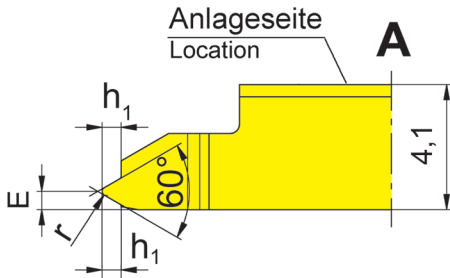
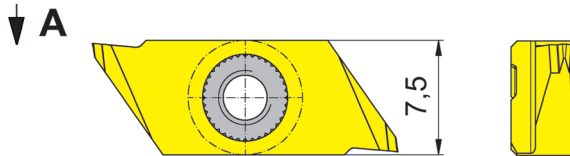

R = rechts wie gezeichnet
R = right hand version shown

L = links spiegelbildlich
L = left hand version

Wechselgenauigkeit
Länge ± 0,015 mm
Indexability length
± 0,015 mm

Bestellnummer Part number	P	E	r	h ₁	Größe Size	IG35	TH35
R/LS274.0305.03.E	0,50	0,40	0,07	0,31	04	ΔΔ	ΔΔ
R/LS274.0306.03.E	0,60	0,45	0,09	0,37	04	ΔΔ	ΔΔ
R/LS274.0307.03.E	0,70	0,50	0,10	0,43	04	ΔΔ	ΔΔ
R/LS274.0407.03.E	0,75	0,50	0,11	0,46	04	ΔΔ	ΔΔ
R/LS274.0408.03.E	0,80	0,55	0,12	0,49	04	ΔΔ	ΔΔ
R/LS274.0610.03.E	1,00	0,60	0,14	0,61	04	ΔΔ	ΔΔ
R/LS274.0712.03.E	1,25	0,70	0,15	0,77	04	ΔΔ	ΔΔ
R/LS274.0915.03.E	1,50	0,80	0,20	0,92	04	ΔΔ	ΔΔ

▲ ab Lager / on stock Δ 4 Wochen / 4 weeks x auf Anfrage / upon request

● empfohlen / recommended

o bedingt einsetzbar / alternative recommendation

- nicht geeignet / not suitable

■ unbeschichtete HM-Sorten / uncoated grades

■ beschichtete HM-Sorten / coated grades

■ bestückt/Cermet / brazed/Cermet

Abmessungen in mm

Dimensions in mm

Ausführung R oder L angeben

State R or L version

Keine Unterlegplatte erforderlich. Sämtliche HORN-Gewindeprofile sind mit einem **KEGELMANTEL-FREISCHLIFF** versehen.
No shims necessary. All HORN thread profiles are manufactured with **full ground radial clearance**.

P	-	•
M	•	•
K	-	•
N	-	•
S	•	•
H	-	-

HM-Sorten
Carbide grades

F

274 μ -Finish μ

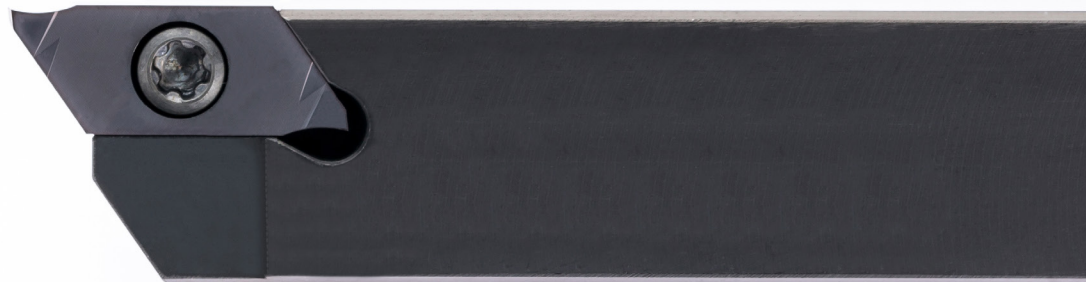

**Klemmhalter mit
Schneidplatten**

Stechbreite 0,5 - 2 mm

**Toolholder with
Inserts**

Width of groove 0,5 - 2 mm

F

Klemmhalter
Toolholder
H274...SF

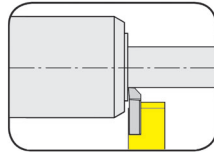

Seite/Page
F49-F50

Wendeschneidplatte
Indexable insert
S274...SF

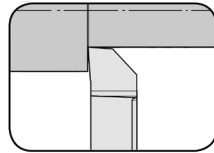

Seite/Page
F51

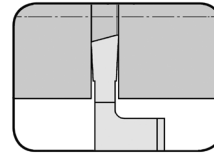

Seite/Page
F54-F55

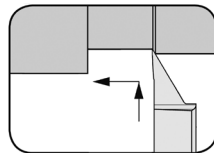

Seite/Page
F52-F53

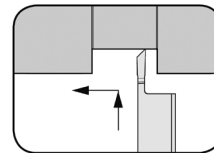

Seite/Page
F56-F57

μ

μ -Finish

ist der Begriff für eine besonders hohe Qualitätsstufe der Schneide. Die gebräuchlichsten Schneidplatten zum Drehen, Einstechen Rückwärtsdrehen und (Ab-)Stechen in der Mikro-Drehbearbeitung der Uhrenindustrie sind als Standard zur Feinstbearbeitung lieferbar. Die Geometrien sind für die Bearbeitung von Stählen wie 20AP, rostfreien Stählen wie 4C27A und Messing der Uhrenindustrie optimiert. In Kombination mit dem Hartmetall und einer neu entwickelten Beschichtung sind Ihnen höchste Standmengen sicher und Sie steigern unweigerlich Ihre Produktivität.

is the term used to describe a particularly high quality of cutting edge. The most frequently used inserts for turning, backturning, grooving and parting off in the micro-turning processes involved in the watch-making industry are available for ultrafine machining. The geometries are optimized for machining steels such as 20AP, stainless steels such as 4C27A and brass used in the watch-making industry. Combination with the carbide and a newly developed coating guarantees maximum tool life quantities and will inevitably improve your productivity.

Einstecken und Drehen

Grooving and Turning



Klemmhalter

Toolholder

H274...SF

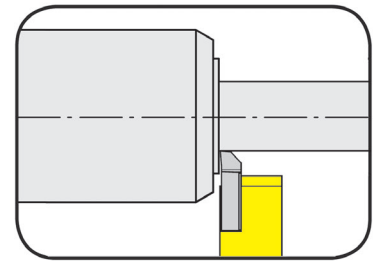

Stechtiefe bis
Stechbreite

Depth of groove up to
Width of groove

6 mm
0,5-2 mm

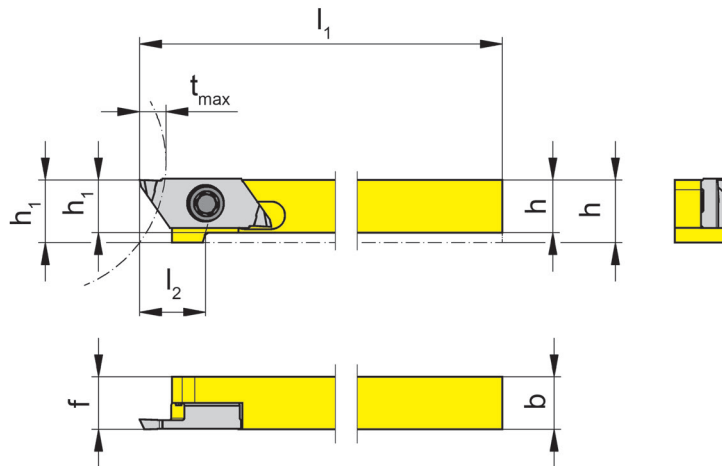

für Wendeschneidplatte
for Indexable insert

Typ S274...SF
Type



R = rechts wie gezeichnet
R = right hand version shown

L = links spiegelbildlich
L = left hand version

Bestellnummer Part number	h	b	l ₁	l ₂	h ₁	f	t _{max}	Größe Size
RH274.0808.SF.04	8	8	100	10	9,5	8	6	04
RH274.1010.SF.04	10	10	100	-	10,0	10	6	04
RH274.1212.SF.04	12	12	100	-	12,0	12	6	04

Weitere Abmessungen auf Anfrage
Further sizes upon request

Abmessungen in mm
Dimensions in mm

t_{max} 6 mm nur bei Werkstück-Ø ≤ 25 mm erreichbar.
t_{max} 6 mm can be reached only with workpiece Ø ≤ 25 mm.

Das Anzugsdrehmoment der Schrauben finden Sie in den Technischen Hinweisen.
For torque specification of the screw, please see Technical Instructions.

Ersatzteile

Spare Parts

Klemmhalter Toolholder	Spannschraube Clamping Screw	TORX PLUS®-Schlüssel TORX PLUS® Wrench
RH274...	030.350P.0852	T15PQ



Einstecken und Drehen

Grooving and Turning



Klemmhalter

Toolholder

H274...SF

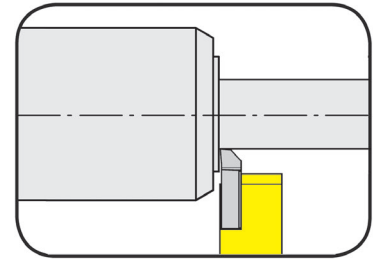

Stechtiefe	Depth of groove	6 mm
Stechbreite	Width of groove	0,5-2 mm

Schaftmaterial: Schwermetall (schwingungsarm)
Material of shank: tungsten alloy (giving good vibration resistance)

für Wendeschneidplatte
for Indexable insert

Typ S274...SF
Type

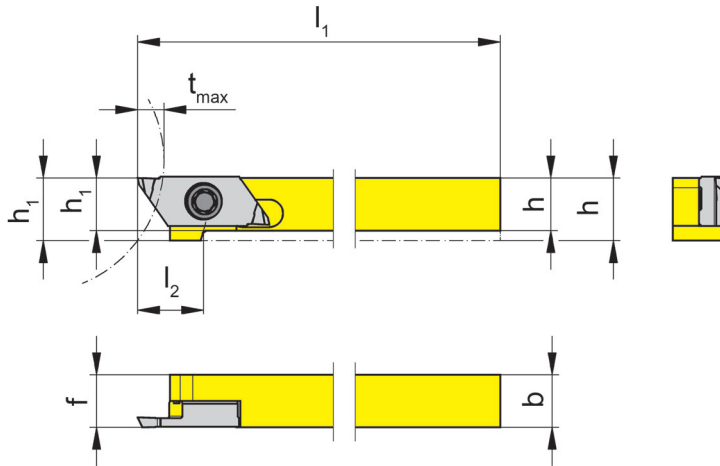

R = rechts wie gezeichnet
R = right hand version shown

L = links spiegelbildlich
L = left hand version

Bestellnummer Part number	h	b	l ₁	l ₂	h ₁	f	t _{max}	Größe Size
RH274.0808.SF.S4	8	8	100	10	9,5	8	6	04
RH274.1010.SF.S4	10	10	100	-	10,0	10	6	04
RH274.1212.SF.S4	12	12	100	-	12,0	12	6	04

Weitere Abmessungen auf Anfrage
Further sizes upon request

Abmessungen in mm
Dimensions in mm

t_{max} 6 mm nur bei Werkstück-Ø ≤ 25 mm erreichbar.
t_{max} 6 mm can be reached only with workpiece Ø ≤ 25 mm.

Das Anzugsdrehmoment der Schrauben finden Sie in den Technischen Hinweisen.
For torque specification of the screw, please see Technical Instructions.

F

Ersatzteile

Spare Parts

Klemmhalter Toolholder	Spannschraube Clamping Screw	TORX PLUS®-Schlüssel TORX PLUS® Wrench
RH274...	030.350P.0852	T15PQ

Längsdrehen

Side Turning



Wendeschneidplatte

Indexable insert

S274...SF

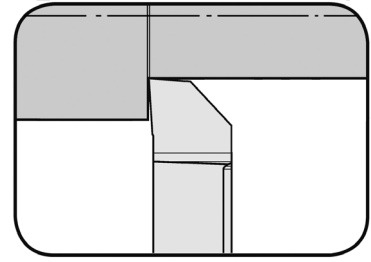

Schnitttiefe bis Depth of cut up to 2,5 mm

präzisionsgeschliffen
precision ground

für Klemhalter
for Toolholder

Typ H274...SF
Type

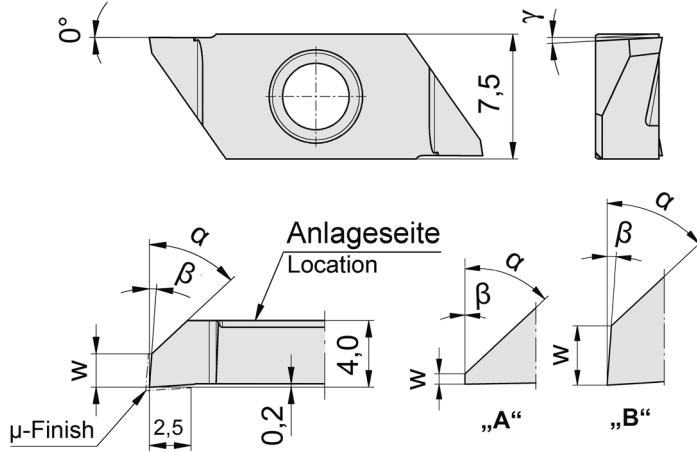

Wechselgenauigkeit
Länge ± 0,015 mm
Indexability length
± 0,015 mm

R = rechts wie gezeichnet
R = right hand version shown

L = links spiegelbildlich
L = left hand version

Bestellnummer Part number	w	γ	α	Form Form	β	Größe Size	MG12	AC25	AC2P	ES15	ES1P
RS274.0547.04.SF	0,05	0°	47°	A	0°	04	○	●	●	●	●
R/LS274.2047.03.SF	2,00	3°	47°	B	4°	04	△/△	△/△	△/△	▲/△	△/△

- ▲ ab Lager / on stock △ 4 Wochen / 4 weeks x auf Anfrage / upon request
- empfohlen / recommended
- bedingt einsetzbar / alternative recommendation
- nicht geeignet / not suitable
- unbeschichtete HM-Sorten / uncoated grades
- beschichtete HM-Sorten / coated grades
- bestückt/Cermet / brazed/Cermet

Abmessungen in mm
Dimensions in mm
Ausführung R oder L angeben
State R or L version

P	○	●	●	●	●
M	-	○	○	○	○
K	-	-	-	●	-
N	-	-	-	-	-
S	-	-	-	-	-
H	-	-	-	-	-

HM-Sorten
Carbide grades



Kopierdrehen (Schlichten)

Copy Turning (Finishing)



Wendeschneidplatte

Indexable insert

S274...SF

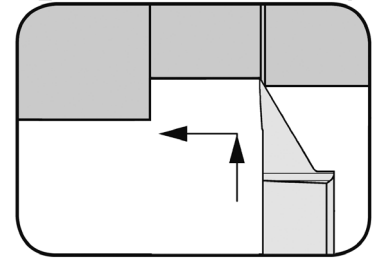

Schnitttiefe bis Depth of cut up to 2,5 mm

präzisionsgeschliffen
precision ground

für Klemhalter
for Toolholder

Typ H274...SF
Type

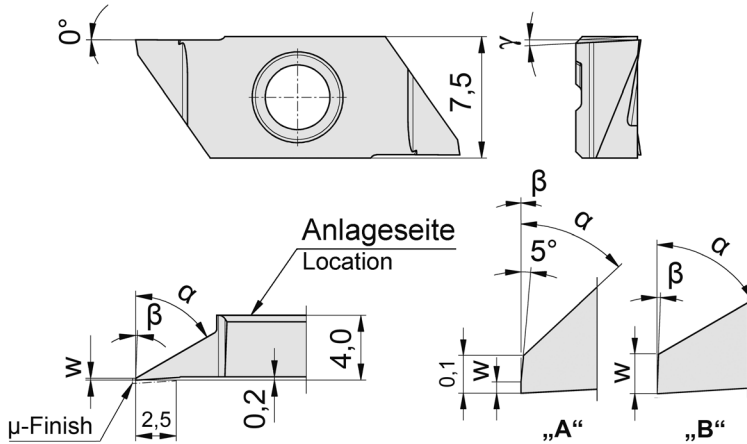

Wechselgenauigkeit
Länge ± 0,015 mm
Indexability length
± 0,015 mm

R = rechts wie gezeichnet
R = right hand version shown

L = links spiegelbildlich
L = left hand version

Bestellnummer Part number	w	γ	α	Form Form	β	Größe Size	MG12	AC25	AC2P	ES15	ES1P
RS274.0147.04.SF	0,030	0°	47°	A	0°	04	○	●	●	●	●
R/LS274.0160.03.SF	0,105	3°	60°	B	2°	04	△/△	△/△	△/△	△/△	△/△

- ▲ ab Lager / on stock Δ 4 Wochen / 4 weeks x auf Anfrage / upon request
- empfohlen / recommended
- bedingt einsetzbar / alternative recommendation
- nicht geeignet / not suitable
- unbeschichtete HM-Sorten / uncoated grades
- beschichtete HM-Sorten / coated grades
- bestückt/Cermet / brazed/Cermet

P	○	●	●	●	●
M	-	○	○	○	○
K	-	-	-	●	-
N	-	-	-	-	-
S	-	-	-	-	-
H	-	-	-	-	-

Abmessungen in mm
Dimensions in mm

Ausführung R oder L angeben
State R or L version

HM-Sorten
Carbide grades

F

Kopierdrehen (Schlichten)

Copy Turning (Finishing)



Wendeschneidplatte

Indexable insert

S274...SF

Schnitttiefe bis Depth of cut up to 4 mm

präzisionsgeschliffen
precision ground

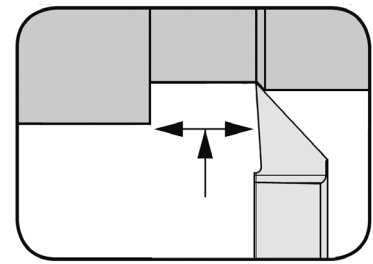

für Klemhalter
for Toolholder

Typ H274...SF
Type

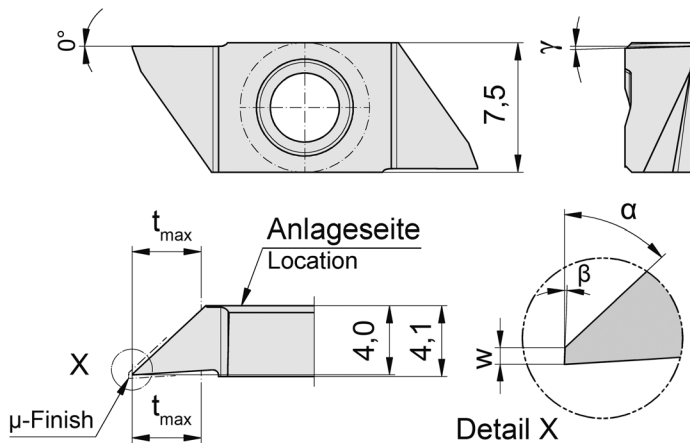

Wechselgenauigkeit
Länge ± 0,015 mm
Indexability length
± 0,015 mm

R = rechts wie gezeichnet
R = right hand version shown

Bestellnummer Part number	w	t _{max}	γ	α	β	Größe Size	AC25	AC2P	ES15	ES1P
RS274.0247.04.SF	0,025	4	1,5°	47°	2°	04	Δ	Δ	▲	Δ

- ▲ ab Lager / on stock Δ 4 Wochen / 4 weeks x auf Anfrage / upon request
- empfohlen / recommended
- o bedingt einsetzbar / alternative recommendation
- nicht geeignet / not suitable
- unbeschichtete HM-Sorten / uncoated grades
- beschichtete HM-Sorten / coated grades
- bestückt/Cermet / brazed/Cermet

Abmessungen in mm
Dimensions in mm

P	●	●	●	●
M	o	o	o	o
K	-	-	●	-
N	-	-	-	-
S	-	-	-	-
H	-	-	-	-

HM-Sorten
Carbide grades



Abstechen

Parting Off



Wendeschneidplatte

Indexable insert

S274...SF

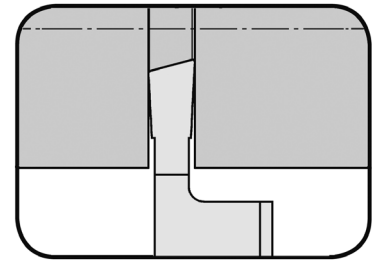

Stechtiefe bis Stechbreite	Depth of groove up to Width of groove	6 mm 0,8-1,5 mm
-------------------------------	--	--------------------

präzisionsgeschliffen
precision ground

für Klemmhalter
for Toolholder

Typ H274...SF
Type

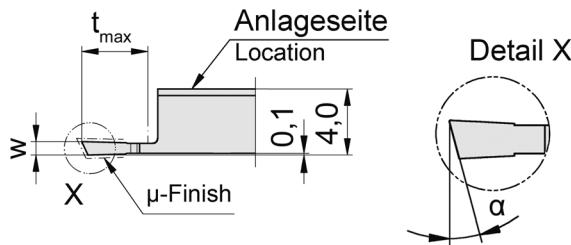
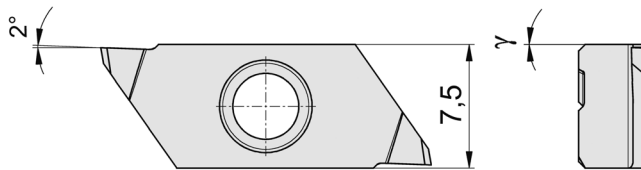

Wechselgenauigkeit
Länge ± 0,015 mm
Indexability length
± 0,015 mm

R = rechts wie gezeichnet
R = right hand version shown

L = links spiegelbildlich
L = left hand version

Bestellnummer Part number	w	t _{max}	α	γ	Größe Size	HM-Sorten Carbide grades				
						MG12	AC25	AC2P	ES15	ES1P
R/LS274.2508.04.SF	0,8	4	25°	0°	04	Δ/Δ	Δ/Δ	Δ/Δ	Δ/Δ	Δ/Δ
RS274.2509.04.SF	0,9	4	25°	0°	04		Δ	Δ	Δ	Δ
RS274.2510.04.SF	1,0	4	25°	0°	04		Δ	Δ	▲	Δ
RS274.2510.06.SF	1,0	6	25°	0°	04		Δ	Δ	Δ	Δ
RS274.2512.06.SF	1,2	6	25°	0°	04		Δ	Δ	Δ	Δ
RS274.2515.06.SF	1,5	6	25°	0°	04		Δ	Δ	Δ	Δ

▲ ab Lager / on stock Δ 4 Wochen / 4 weeks x auf Anfrage / upon request

● empfohlen / recommended

o bedingt einsetzbar / alternative recommendation

- nicht geeignet / not suitable

□ unbeschichtete HM-Sorten / uncoated grades

■ beschichtete HM-Sorten / coated grades

■ bestückt/Cermet / brazed/Cermet

Abmessungen in mm

Dimensions in mm

Ausführung R oder L angeben

State R or L version

t_{max} 6 mm nur bei Werkstück-Ø ≤ 25 mm erreichbar.

t_{max} 6 mm can be reached only with workpiece Ø ≤ 25 mm.

P	o	●	●	●	●
M	-	o	o	o	o
K	-	-	-	●	-
N	-	-	-	-	-
S	-	-	-	-	-
H	-	-	-	-	-

HM-Sorten
Carbide grades

F

Abstechen

Parting Off



Wendeschneidplatte

Indexable insert

S274...SF

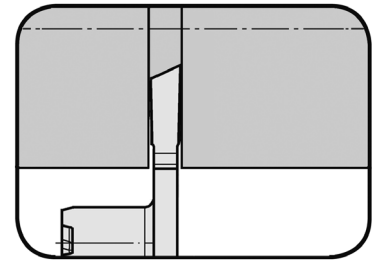

Stechtiefe bis Stechbreite	Depth of groove up to Width of groove	6 mm 0,8-1,5 mm
-------------------------------	--	--------------------

präzisionsgeschliffen
precision ground

für Klemmhalter
for Toolholder

Typ H274...SF
Type

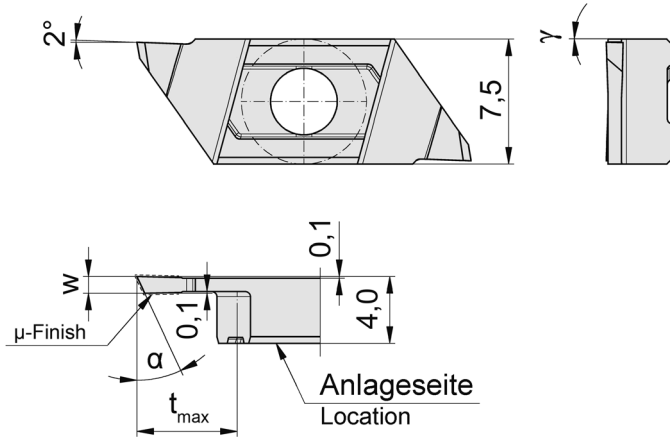

Wechselgenauigkeit
Länge ± 0,015 mm
Indexability length
± 0,015 mm

L = links wie gezeichnet
L = left hand version shown

Bestellnummer Part number	w	t _{max}	α	γ	Größe Size	AC25	AC2P	ES15	ES1P
LS274.2508.04.SF.R	0,8	4	25°	0°	04	Δ	Δ	Δ	Δ
LS274.2509.04.SF.R	0,9	4	25°	0°	04	Δ	Δ	Δ	Δ
LS274.2510.06.SF.R	1,0	6	25°	0°	04	Δ	Δ	Δ	Δ
LS274.2512.06.SF.R	1,2	6	25°	0°	04	Δ	Δ	Δ	Δ
LS274.2515.06.SF.R	1,5	6	25°	0°	04	Δ	Δ	▲	Δ

▲ ab Lager / on stock Δ 4 Wochen / 4 weeks x auf Anfrage / upon request

● empfohlen / recommended

o bedingt einsetzbar / alternative recommendation

- nicht geeignet / not suitable

■ unbeschichtete HM-Sorten / uncoated grades

■ beschichtete HM-Sorten / coated grades

■ bestückt/Cermet / brazed/Cermet

Abmessungen in mm

Dimensions in mm

t_{max} 6 mm nur bei Werkstück-Ø ≤ 25 mm erreichbar.

t_{max} 6 mm can be reached only with workpiece Ø ≤ 25 mm.

P	●	●	●	●
M	o	o	o	o
K	-	-	●	-
N	-	-	-	-
S	-	-	-	-
H	-	-	-	-

HM-Sorten
Carbide grades



Einstecken/Rückwärtsdrehen

Grooving/Backturning



Wendeschneidplatte

Indexable insert

S274...SF

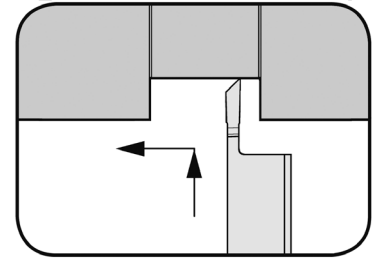

Stechtiefe bis Stechbreite	Depth of groove up to Width of groove	6 mm 0,8-1,8 mm
-------------------------------	--	--------------------

präzisionsgeschliffen
precision ground

für Klemhalter
for Toolholder

Typ H274...SF
Type

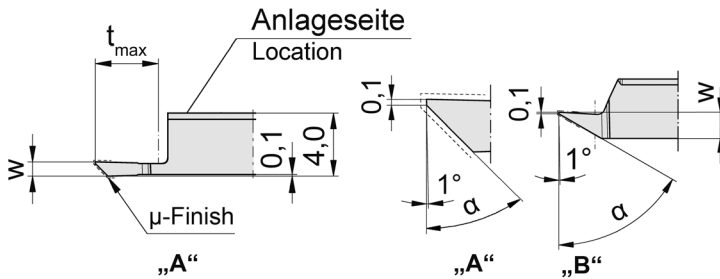
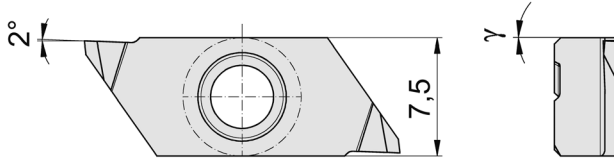

R = rechts wie gezeichnet
R = right hand version shown

L = links spiegelbildlich
L = left hand version



Wechselgenauigkeit
Länge ± 0,015 mm
Indexability length
± 0,015 mm

Bestellnummer Part number	w	t _{max}	α	γ	Form Form	Größe Size	MG12	AC25	AC2P	ES15	ES1P
RS274.4508.04.SF	0,8	4,0	45°	0°	A	04		Δ	Δ	Δ	Δ
R/LS274.4509.04.SF	0,9	4,0	45°	0°	A	04	Δ/Δ	Δ/Δ	Δ/Δ	▲/Δ	Δ/Δ
RS274.4510.06.SF	1,0	6,0	45°	0°	A	04		Δ	Δ	▲	Δ
RS274.4512.06.SF	1,2	6,0	45°	0°	A	04		Δ	Δ	Δ	Δ
RS274.6015.02.SF	1,8	2,5	60°	0°	B	04		Δ	Δ	▲	Δ
RS274.7010.02.SF	1,2	2,5	70°	0°	B	04		Δ	Δ	Δ	Δ

▲ ab Lager / on stock Δ 4 Wochen / 4 weeks x auf Anfrage / upon request

● empfohlen / recommended

o bedingt einsetzbar / alternative recommendation

- nicht geeignet / not suitable

■ unbeschichtete HM-Sorten / uncoated grades

■ beschichtete HM-Sorten / coated grades

■ bestückt/Cermet / brazed/Cermet

Abmessungen in mm

Dimensions in mm

Ausführung R oder L angeben

State R or L version

t_{max} 6 mm nur bei Werkstück-Ø ≤ 25 mm erreichbar.

t_{max} 6 mm can be reached only with workpiece Ø ≤ 25 mm.

P	o	●	●	●	●
M	-	o	o	o	o
K	-	-	-	●	-
N	-	-	-	-	-
S	-	-	-	-	-
H	-	-	-	-	-

HM-Sorten
Carbide grades

Einstecken/Rückwärtsdrehen

Grooving/Backturning



Wendeschneidplatte

Indexable insert

S274...SF

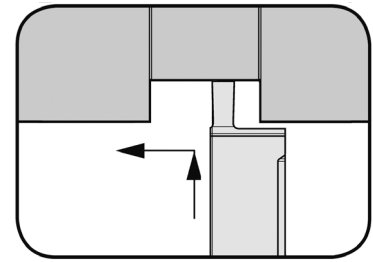

Stechtiefe bis Stechbreite	Depth of groove up to Width of groove	3 mm 0,5-2 mm
-------------------------------	--	------------------

präzisionsgeschliffen
precision ground

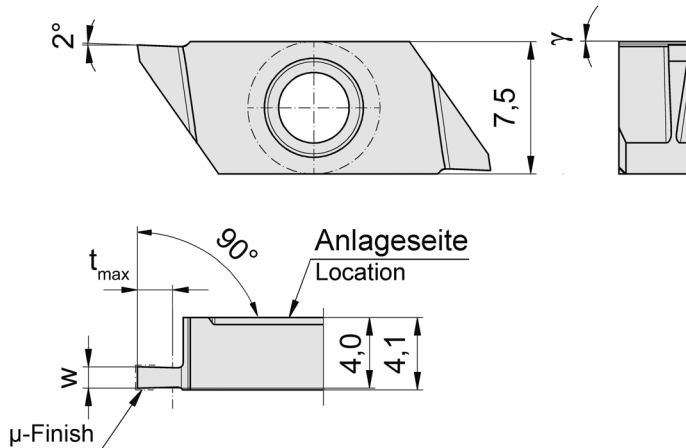

für Klemmhalter
for Toolholder

Typ H274...SF
Type



Wechselgenauigkeit
Länge ± 0,015 mm
Indexability length
± 0,015 mm

R = rechts wie gezeichnet
R = right hand version shown

Bestellnummer Part number	w	t _{max}	γ	Größe Size	AC25	AC2P	ES15	ES1P
RS274.0005.01.SF	0,5	1	0°	04	Δ	Δ	▲	Δ
RS274.0010.02.SF	1,0	2	0°	04	Δ	Δ	▲	Δ
RS274.0012.02.SF	1,2	2	0°	04	Δ	Δ	Δ	Δ
RS274.0015.03.SF	1,5	3	0°	04	Δ	Δ	Δ	Δ
RS274.0020.03.SF	2,0	3	0°	04	Δ	Δ	Δ	Δ

▲ ab Lager / on stock Δ 4 Wochen / 4 weeks x auf Anfrage / upon request

● empfohlen / recommended

o bedingt einsetzbar / alternative recommendation

- nicht geeignet / not suitable

■ unbeschichtete HM-Sorten / uncoated grades

■ beschichtete HM-Sorten / coated grades

■ bestückt/Cermet / brazed/Cermet

Abmessungen in mm

Dimensions in mm

P	●	●	●	●
M	o	o	o	o
K	-	-	●	-
N	-	-	-	-
S	-	-	-	-
H	-	-	-	-

HM-Sorten
Carbide grades



Werkzeuginformationen / Tool information	
Hersteller / Machine manufacturer	HORN
Schneidengüte / Cutting edge quality	μ-Finish
Bestellnummer / Part number	LS274.2047.03.SF ES15
Beschichtung / Coating	ES15
Schneidenzahl der WSP / Cutting edge number	2

Bearbeitung / Machining

Außendrehenschlichtoperation / External rotation finishing operation

Werkstück / Workpiece	
Material / Material	4C27A, Rohmaterial Ø 6 mm 4C27A, Feedstock Ø 6 mm
Bearbeitungsdurchmesser / Machining diameter	5.005 mm
Bearbeitungslänge / Machining length	0.35 mm

Schnittdaten Cutting data	Test / Test 1 aktuell current	Test / Test 2 HORN LS274.2047.03.SF ES15
Drehzahl $n = U/\text{min}$ Revolutions $n = \text{rev}/\text{min}$	2865	4135
Schnittgeschwindigkeit $v_c = \text{m}/\text{min}$ Cutting speed $v_c = \text{m}/\text{min}$	45	65
Vorschub/Umdrehung $s = \text{mm}/U$ Feed rate/revolution $s = \text{mm}/\text{rev}$	0,003	0,008
Vorschub $v_f = \text{mm}/\text{min}$ Feed rate $v_f = \text{mm}/\text{min}$	8,595	33,08
Schnitttiefe $a_p = \text{mm}$ Depth of cut $a_p = \text{mm}$	0,025	0,025

Bewertung / Review		
Bewertung Oberflächengüte optisch Optical surface quality	mittel medium	homogen, sehr gut homogeneous, excellent
Maßhaltigkeit Size accuracy	konstant constant	konstant constant
Standmenge Tool life	200	3000 +!

Material	ES15	ES1P	Bewertung
20AP (mit Blei)		X	optimales Substrat, maßhaltige Fertigung, sehr gute Oberflächengüte
20AP (ohne Blei)		X	optimales Substrat, maßhaltige Fertigung, sehr gute Oberflächengüte
Rostfreier Stahl	X		optimales Substrat, maßhaltige Fertigung, sehr gute Oberflächengüte
4C27A	X		optimales Substrat, maßhaltige Fertigung, sehr gute Oberflächengüte

Material	ES15	ES1P	Review
20AP (with lead)		X	ideal application material, good tool life, dimensional stable, very good surface qualities
20AP (without lead)		X	ideal application material, good tool life, dimensional stable, very good surface qualities
Stainless steel	X		ideal application material, good tool life, dimensional stable, very good surface qualities
4C27A	X		ideal application material, good tool life, dimensional stable, very good surface qualities

μ-Finish - Vorteile im Überblick

μ-Finish - Benefits at a glance



- ✓ feinstgeschliffene scharfe Schneiden
- ✓ exakte Spitzenhöhe der Schneide +/-0,0025 mm
- ✓ reduzierte Einricht- und Stillstandszeiten
- ✓ neue Beschichtung ES1 / ES1P für höchste Standzeiten
- ✓ Schneidplatten nach Kundenspezifikation herstellbar

- ✓ Exceptionally fine-ground sharp cutting edges
- ✓ Exact centre height of the cutting edge +/-0.0025 mm
- ✓ Reduced set-up times and downtimes
- ✓ New ES1 / ES1P coating for maximum durability
- ✓ Inserts can be manufactured according to customer specifications

Wendeschneidplatte - Schneidenkontur absolut ausbruchsfrei!

Indexable insert - cutting contour with absolutely no chipping!

F

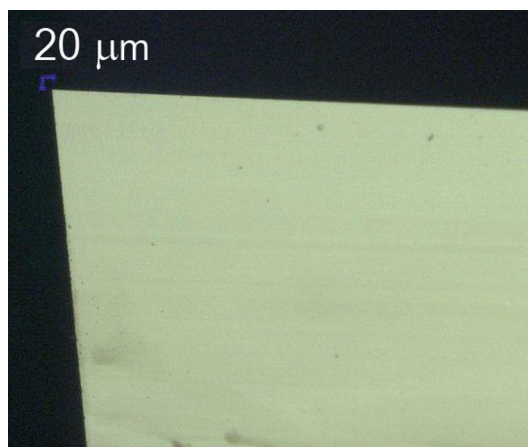

312



**Klemmhalter mit
Schneidplatten**

Stechbreite 0,5 - 6,3 mm

**Toolholder with
Inserts**

Width of groove 0,5 - 6,3 mm

G

Klemmhalter
Toolholder
360/361/369/391/368

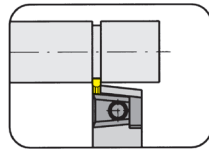

Seite/Page
G3-G5, G9

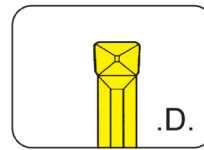

Seite/Page
G17

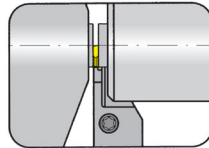

Seite/Page
G6-G7

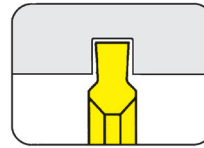

Seite/Page
G18, G22



Seite/Page
G8

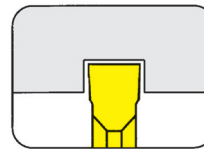

Seite/Page
G19-G21

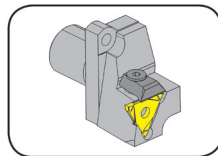

Seite/Page
G9

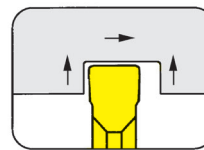

Seite/Page
G23

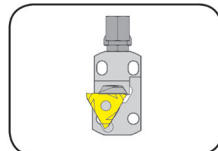

Seite/Page
G11-G13

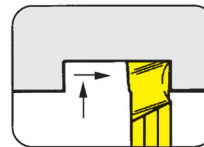

Seite/Page
G24

Wendeschneidplatte
Indexable insert
S312/312

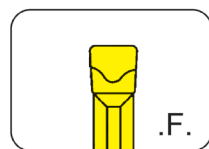

Seite/Page
G14

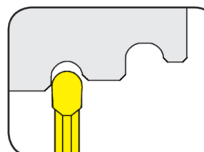

Seite/Page
G25

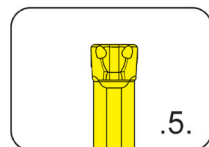

Seite/Page
G15

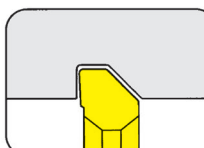

Seite/Page
G26-G27

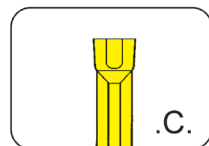

Seite/Page
G16

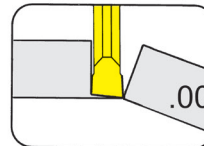

Seite/Page
G28-G32

Einstechen und Abstechen

Grooving and Parting Off



Klemmhalter

Toolholder

360

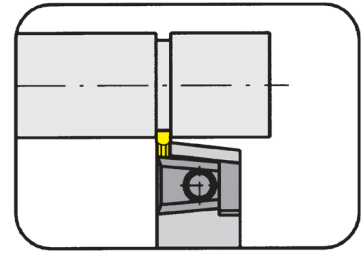

Stechtiefe bis Spannbereich	Depth of groove up to Clamping range	6 mm 0,5-6,3 mm
--------------------------------	---	--------------------

für Wendeschneidplatte
for Indexable insert

Typ 312
Type S312
N312

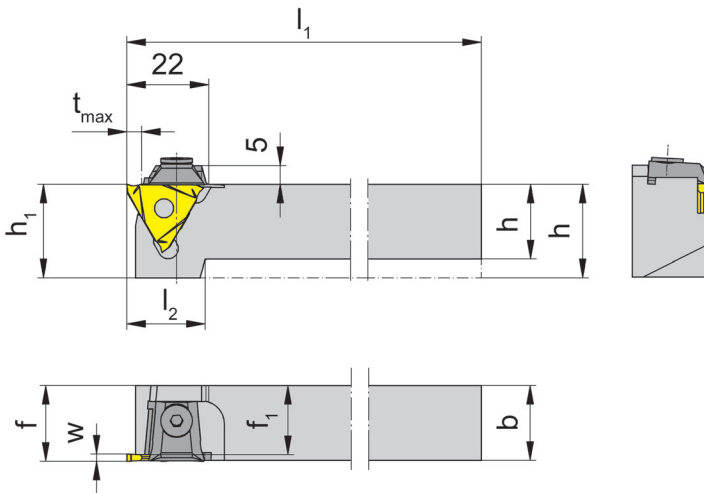

R = rechts wie gezeichnet
R = right hand version shown

L = links spiegelbildlich
L = left hand version

Bestellnummer Part number	h	b	l ₁	l ₂	h ₁	f ₁	f	t _{max}	Größe Size	Spannbereich Clamping range
R/L360.1212.01	12	12	100	24	25	10,5	f ₁ +w-a ₁	4	01	0,5-1,9
R/L360.1616.01	16	16	125	22	25	14,5	f ₁ +w-a ₁	4	01	0,5-1,9
R/L360.1212.02	12	12	100	24	25	9,5	f ₁ +w-a ₁	6	02	1,9-2,9
R/L360.1616.02	16	16	125	22	25	13,5	f ₁ +w-a ₁	6	02	1,9-2,9
R/L360.1212.03	12	12	100	24	25	8,5	f ₁ +w-a ₁	6	03	2,9-3,9
R/L360.1616.03	16	16	125	22	25	12,5	f ₁ +w-a ₁	6	03	2,9-3,9
R/L360.1616.04	16	16	125	22	25	10,8	f ₁ +w-a ₁	6	04	3,9-6,3

Ausführung R oder L angeben
State R or L version

w, a, siehe WSP
w, a, see indexable inserts

Abmessungen in mm
Dimensions in mm

Weitere Abmessungen auf Anfrage
Further sizes upon request

t_{max} nur bei Werkstück-Ø ≤ 40 mm erreichbar.
t_{max} can be reached only with workpiece Ø ≤ 40 mm

Das Anzugsdrehmoment der Schrauben finden Sie in den Technischen Hinweisen.
For torque specification of the screw, please see Technical Instructions.

Ersatzteile

Spare Parts

Klemmhalter Toolholder	Inbus-Schlüssel Allen Wrench	Spannelement Clamping element
R/L360...	SW3,0 DIN911	11.3
R/L360.1616.04	SW3,0 DIN911	13.4

G

Einstechen und Abstechen

Grooving and Parting Off



Klemmhalter

Toolholder

360

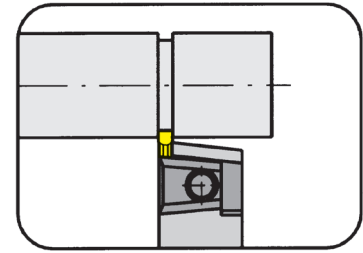

Stechtiefe bis Spannbereich	Depth of groove up to Clamping range	6 mm 0,5-3,9 mm
--------------------------------	---	--------------------

für Wendeschneidplatte
for Indexable insert

Typ 312
Type S312
N312

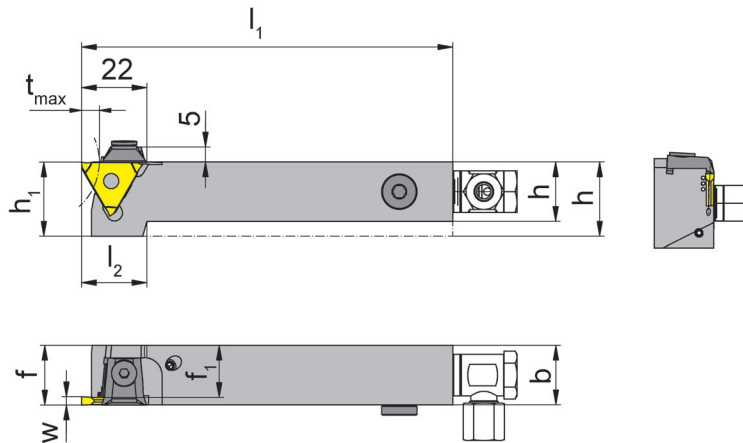

R = rechts wie gezeichnet
R = right hand version shown

L = links spiegelbildlich
L = left hand version

mit innerer
Kühlmittelzufuhr
with through coolant supply

Bestellnummer Part number	h	b	l ₁	l ₂	h ₁	f ₁	f	t _{max}	Größe Size	Spannbereich Clamping range
R/L360.1212.01.IK	12	12	100	24	25	10,5	f ₁ +w-a ₁	4	01	0,5-1,9
R/L360.1616.01.IK	16	16	125	22	25	14,5	f ₁ +w-a ₁	4	01	0,5-1,9
R/L360.1212.02.IK	12	12	100	24	25	9,5	f ₁ +w-a ₁	6	02	1,9-2,9
R/L360.1616.02.IK	16	16	125	22	25	13,5	f ₁ +w-a ₁	6	02	1,9-2,9
R/L360.1212.03.IK	12	12	100	24	25	8,5	f ₁ +w-a ₁	6	03	2,9-3,9
R/L360.1616.03.IK	16	16	125	22	25	12,5	f ₁ +w-a ₁	6	03	2,9-3,9

Ausführung R oder L angeben
State R or L version

w, a, siehe WSP
w, a, see indexable inserts

Abmessungen in mm
Dimensions in mm

t_{max} nur bei Werkstück-Ø ≤ 40 mm erreichbar.
t_{max} can be reached only with workpiece Ø ≤ 40 mm

Das Anzugsdrehmoment der Schrauben finden Sie in den Technischen Hinweisen.
For torque specification of the screw, please see Technical Instructions.

G

Ersatzteile

Spare Parts

Klemmhalter Toolholder	Gewindestift Threaded Pin	Inbus-Schlüssel Allen Wrench	Kühlmittelsanschluss Coolant supply	Spannelement Clamping element	Dichtstopfen Sealing plug
R/L360.1212....	3.03.913	SW2,0 DIN911	004.00.61	11.3	
R/L360.1616....	18.05.913	SW3,0 DIN911	004.00.16	11.3	
R/L360.1616.01/03.IK	18.05.913	SW3,0 DIN911	004.00.16	11.3	004.00.26

Einstecken (außen)

Grooving (external)



Klemmhalter

Toolholder

361

verringerte Kopfgröße
reduced head size

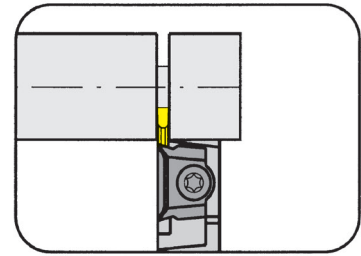

Stechtiefe bis
Spannbereich

Depth of groove up to
Clamping range

6 mm
0,5-3,9 mm

für Wendeschneidplatte
for Indexable insert

Typ 312
Type S312
N312

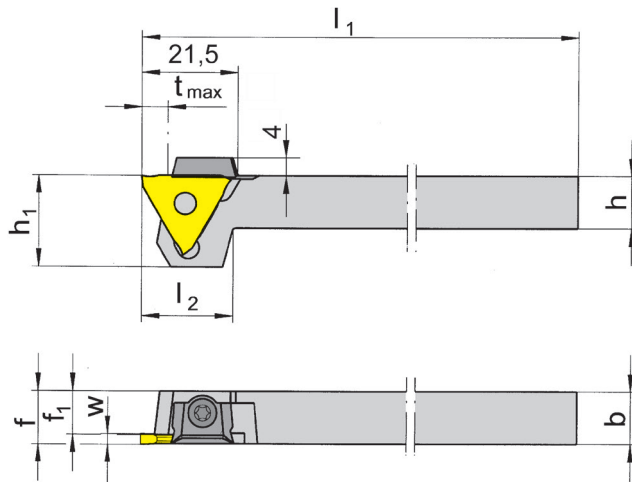

R = rechts wie gezeichnet
R = right hand version shown

L = links spiegelbildlich
L = left hand version

Bestellnummer Part number	h	b	l ₁	l ₂	h ₁	f ₁	f	t _{max}	Größe Size	Spannbereich Clamping range
R/L361.1212.01	12	12	100	17	19	10,5	f ₁ +w-a ₁	4	01	0,5-1,9
R/L361.1212.02	12	12	100	17	19	9,5	f ₁ +w-a ₁	6	02	1,9-2,9
R/L361.1212.03	12	12	100	21	21	8,5	f ₁ +w-a ₁	6	03	2,9-3,9

Ausführung R oder L angeben
State R or L version

w, a₁ siehe WSP
w, a₁ see indexable inserts

Abmessungen in mm
Dimensions in mm

Weitere Abmessungen auf Anfrage
Further sizes upon request

t_{max} nur bei Werkstück-Ø ≤ 40 mm erreichbar.
t_{max} can be reached only with workpiece Ø ≤ 40 mm

Das Anzugsdrehmoment der Schrauben finden Sie in den Technischen Hinweisen.
For torque specification of the screw, please see Technical Instructions.

Ersatzteile

Spare Parts

Klemmhalter Toolholder	Spannelement Clamping element	Spannschraube Clamping Screw	TORX PLUS®-Schlüssel TORX PLUS® Wrench
R/L361...	12.3	030.0422.T10P	T10PL

G

Abstechen

Parting Off



Klemmhalter

Toolholder

368

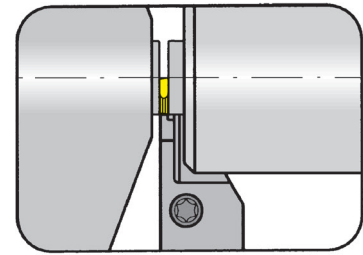

Stechtiefe bis Stechbreite	Depth of groove up to Width of groove	8 mm 0,5-1,5 mm
-------------------------------	--	--------------------

für TRAUB-Maschinen (TNL12/7)
for machines TRAUB (TNL12/7)

für Wendeschneidplatte
for Indexable insert

Typ 312 w < 1,5 mm
Type

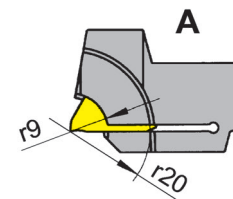
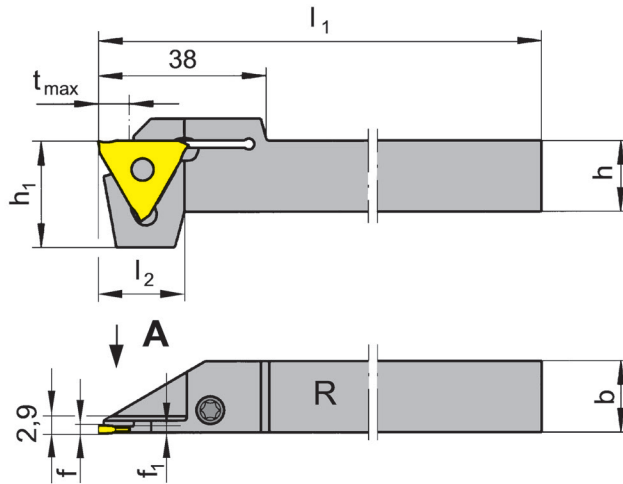

nur für umfangs-
geschliffene Form-WSP
only for periferal grounded
profiled inserts

R = rechts wie gezeichnet
R = right hand version shown

L = links spiegelbildlich
L = left hand version

Bestellnummer Part number	h	b	l ₁	l ₂	h ₁	f ₁	f	t _{max}
R/L368.1212.08	12	12	95	19,5	24	1,0	f ₁ +a ₁	8
R/L368.1212.11	12	12	95	19,5	24	1,3	f ₁ +a ₁	8
R/L368.1616.08	16	16	95	19,5	24	1,0	f ₁ +a ₁	8
R/L368.1616.11	16	16	95	19,5	24	1,3	f ₁ +a ₁	8

Ausführung R oder L angeben
State R or L version

a₁ siehe WSP
a₁ see indexable inserts

Abmessungen in mm
Dimensions in mm

Halter R/L368...08 für WSP:

R/L312.0805... / R/L312.0808... / R/L312.0510... R/L312.0512... / R/L312.1210... / R/L312.0012...

Toolholder R/L368...08 for indexable inserts:

R/L312.0805... / R/L312.0808... / R/L312.0510... R/L312.0512... / R/L312.1210... / R/L312.0012...

Halter R/L368...11 für WSP:

R/L312.0515... / R/L312.0015...V1

Toolholder R/L368...11 for indexable inserts:

R/L312.0515... / R/L312.0015...V1

Das Anzugsdrehmoment der Schrauben finden Sie in den Technischen Hinweisen.

For torque specification of the screw, please see Technical Instructions.

G

Ersatzteile

Spare Parts

Klemmhalter Toolholder	Spannschraube Clamping Screw	TORX PLUS®-Schlüssel TORX PLUS® Wrench
R/L368...	4.15T15P	T15PQ

Abstechen

Parting Off



Klemmhalter

Toolholder

368

mit innerer Kühlmittelzufuhr
with through coolant supply

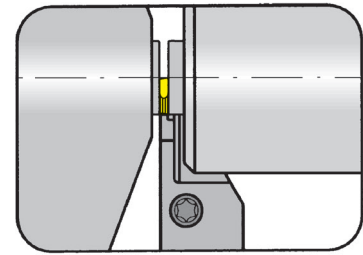

Stechtiefe bis Stechbreite	Depth of groove up to Width of groove	8 mm 0,5-1,5 mm
-------------------------------	--	--------------------

für TRAUB-Maschinen (TNL12/7)
for machines TRAUB (TNL12/7)

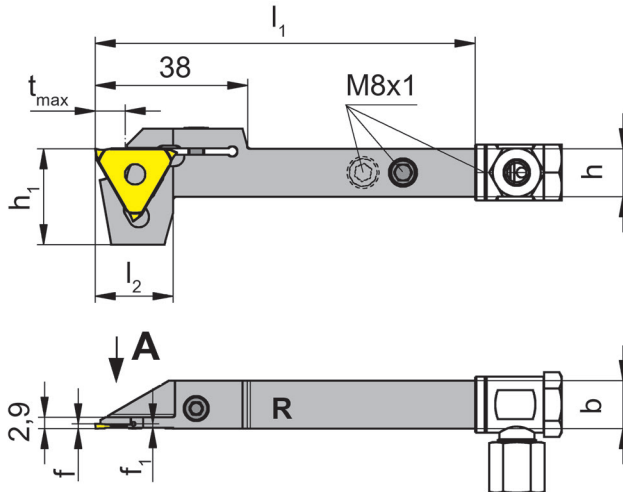

R = rechts wie gezeichnet
R = right hand version shown

L = links spiegelbildlich
L = left hand version

für Wendeschneidplatte
for Indexable insert

Typ 312 w ≤ 1,5 mm
Type

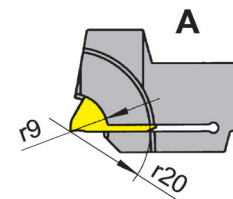

nur für umfangs-
geschliffene Form-WSP
only for periferal grounded
profiled inserts

Bestellnummer Part number	h	b	l ₁	l ₂	h ₁	f ₁	f	t _{max}
R/L368.1212.08.IK	12	12	95	19,5	24	1,0	f ₁ +a ₁	8
R/L368.1212.11.IK	12	12	95	19,5	24	1,3	f ₁ +a ₁	8
R/L368.1616.08.IK	16	16	95	19,5	24	1,0	f ₁ +a ₁	8
R/L368.1616.11.IK	16	16	95	19,5	24	1,3	f ₁ +a ₁	8

Ausführung R oder L angeben
State R or L version

a₁ siehe WSP
a₁ see indexable inserts

Abmessungen in mm
Dimensions in mm

Halter R/L368...08.IK für WSP:

R/L312.0805... / R/L312.0808... / R/L312.0510... R/L312.0512... / R/L312.1210... / R/L312.0012...

Toolholder R/L368...08.IK for indexable inserts:

R/L312.0805... / R/L312.0808... / R/L312.0510... R/L312.0512... / R/L312.1210... / R/L312.0012...

Halter R/L368...11.IK für WSP:

R/L312.0515... / R/L312.0015...V1

Toolholder R/L368...11.IK for indexable inserts

R/L312.0515... / R/L312.0015...V1

Das Anzugsdrehmoment der Schrauben finden Sie in den Technischen Hinweisen.

For torque specification of the screw, please see Technical Instructions.

Ersatzteile

Spare Parts

Klemmhalter Toolholder	Spannschraube Clamping Screw	Gewindestift Threaded Pin	Kühlmittelanschluss Coolant supply	TORX PLUS®-Schlüssel TORX PLUS® Wrench
R/L368.1212...	4.15T15P	3.03.913	004.00.61	T15PQ
R/L368.1616...	4.15T15P	18.05.913	004.00.16	T15PQ

Klemmhalter

Toolholder

912

mit innerer Kühlmittelzufuhr
with through coolant supply



Stechtiefe bis Depth of groove up to 6 mm

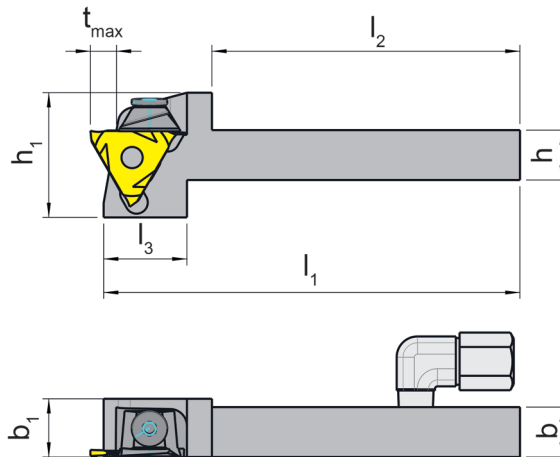

für Wendeschneidplatte
for Indexable insert

Typ 312
Type S312
 N312

R = rechts wie gezeichnet
R = right hand version shown

L = links spiegelbildlich
L = left hand version

Bestellnummer Part number	h	b	l ₁	l ₃	h ₁	l ₂	t _{max}	Spannbereich Clamping range
912.L.1012.01.IK	10	12	100	20	30	74	6	0,5-1,9
912.L.1012.02.IK	10	12	100	20	30	74	6	1,9-2,9
912.L.1212.01.IK	12	12	100	20	30	74	6	0,5-1,9
912.L.1212.02.IK	12	12	100	20	30	74	6	1,9-2,9
912.L.1616.01.IK	16	16	100	20	34	74	6	0,5-1,9
912.L.1616.02.IK	16	16	100	20	34	74	6	1,9-2,9
912.R.1012.01.IK	10	12	100	20	30	74	6	0,5-1,9
912.R.1012.02.IK	10	12	100	20	30	74	6	1,9-2,9
912.R.1212.01.IK	12	12	100	20	30	74	6	0,5-1,9
912.R.1212.02.IK	12	12	100	20	30	74	6	1,9-2,9
912.R.1616.01.IK	16	16	100	20	34	74	6	0,5-1,9
912.R.1616.02.IK	16	16	100	20	34	74	6	1,9-2,9

Abmessungen in mm
Dimensions in mm

G

Ersatzteile

Klemmhalter Toolholder	Kühlmittelanschluss Coolant supply
912...	004.00.22

Einstecken und Drehen

Grooving and Turning



Klemmhalter

Toolholder

369

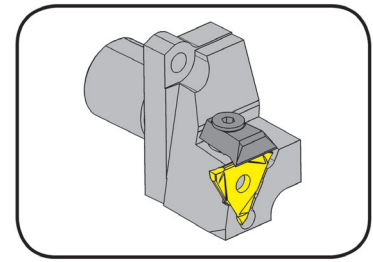

Stechtiefe Spannbereich	Depth of groove Clamping range	4-6 mm 0,5-2,9 mm
----------------------------	-----------------------------------	----------------------

Lochbild 13,7 x 37,6 mm
Hole pattern 13,7 x 37,6 mm

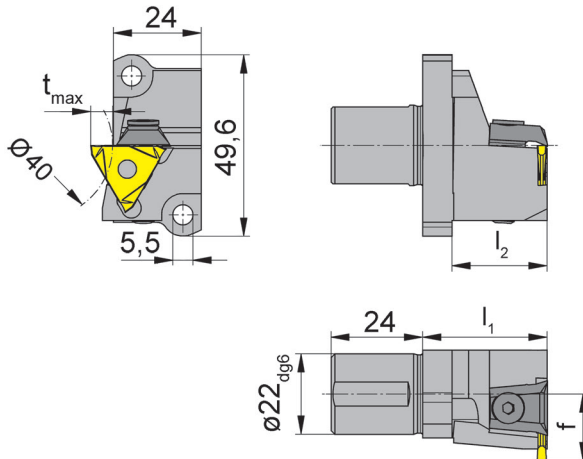

für Wendeschneidplatte
for Indexable insert

Typ 312
Type S312
N312

für Star
Langdrehautomaten
for Swiss type machines Star

L = links wie gezeichnet
L = left hand version shown

Bestellnummer Part number	l_2	f	t_{max}	l_1	Größe Size	Spannbereich Clamping range
L369.A022.18.01	26	18,2	4	34	01	0,5-1,9
L369.A022.18.02	26	18,2	6	34	02	1,9-2,9

Weitere Abmessungen auf Anfrage
Further sizes upon request

Abmessungen in mm
Dimensions in mm

Das Anzugsdrehmoment der Schrauben finden Sie in den Technischen Hinweisen.
For torque specification of the screw, please see Technical Instructions.

Star Langdrehautomaten: ECAS-12/20, SB16D/E, SR-20, SR20J/JN, RS-20RII, RS-20RIII, RS-20RIV, RS-32J/JN, SW-12RIII

Swiss Type Machines Star: ECAS-12/20, SB16D/E, SR-20, SR20J/JN, RS-20RII, RS-20RIII, RS-20RIV, RS-32J/JN, SW-12RII

Ersatzteile

Spare Parts

Klemmhalter Toolholder	Inbus-Schlüssel Allen Wrench	Spannelement Clamping element
L369...	SW3,0 DIN911	16.4

G

Einstecken (außen)

Grooving (external)



Klemmhalter

Toolholder

391

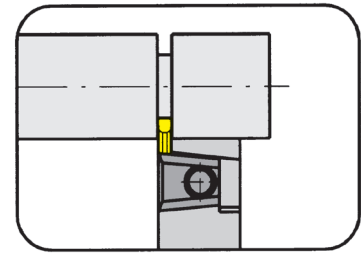

Stechtiefe bis
Spannbereich

Depth of groove up to
Clamping range

8 mm
0,5-1,9 mm

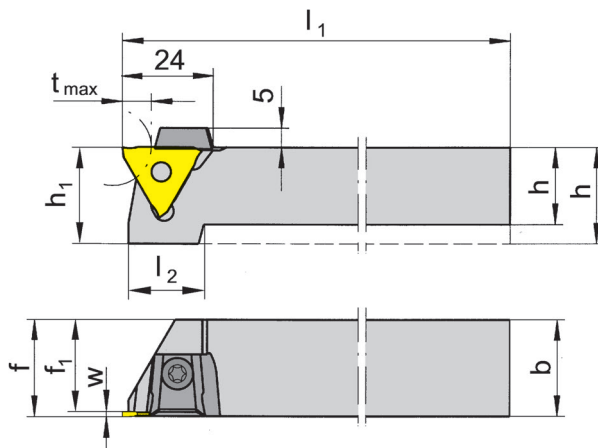

für Wendeschneidplatte
for Indexable insert

Typ 312
Type S312
N312

R = rechts wie gezeichnet
R = right hand version shown

L = links spiegelbildlich
L = left hand version

Bestellnummer Part number	h	b	l ₁	l ₂	h ₁	f ₁	f	t _{max}	Größe Size	Spannbereich Clamping range
R/L391.1212.01	12	12	100	21	21	10,5	f ₁ +w-a ₁	8	01	0,5-1,9
R/L391.1616.01	16	16	125	21	21	14,5	f ₁ +w-a ₁	8	01	0,5-1,9

Ausführung R oder L angeben
State R or L version

w, a₁ siehe WSP
w, a₁ see indexable inserts

Abmessungen in mm
Dimensions in mm

Weitere Abmessungen auf Anfrage
Further sizes upon request

t_{max} nur bei Werkstück-Ø ≤ 20 mm erreichbar.
t_{max} can be reached only with workpiece Ø ≤ 20 mm

Das Anzugsdrehmoment der Schrauben finden Sie in den Technischen Hinweisen.
For torque specification of the screw, please see Technical Instructions.

G

Ersatzteile

Spare Parts

Klemmhalter Toolholder	Spannelement Clamping element	TORX PLUS®-Schlüssel TORX PLUS® Wrench
R/L391.1212.01	12.3	T10PL
R/L391.1616.01	14.4	T15PQ

Einstecken und Drehen

Grooving and Turning



Einbauhalter Graf

Cartridge Graf

64/65

mit innerer Kühlmittelzufuhr
with through coolant supply

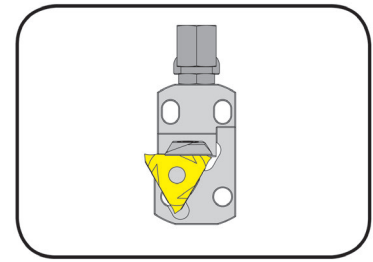

Stechtiefe
Spannbereich

Depth of groove
Clamping range

4 mm
0,5-2,9 mm

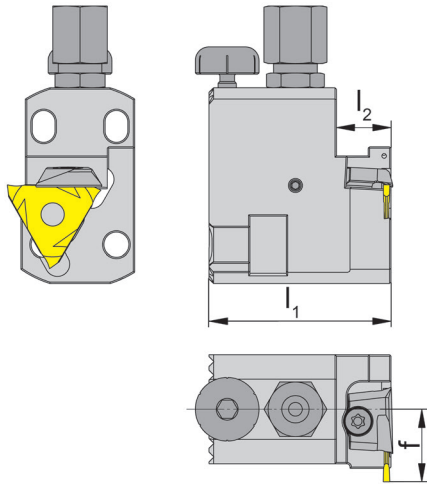

für Wendeschneidplatte
for Indexable insert

Typ 312
Type S312
N312

R = rechts wie gezeichnet
R = right hand version shown

L = links spiegelbildlich
L = left hand version

Bestellnummer Part number	l_1	l_2	f	Größe Size	Spannbereich Clamping range
R/L.64.IK	40	12	16	01	0,5-1,9
R/L.65.IK	40	12	16	02	1,9-2,9

Ausführung R oder L angeben
State R or L version

Abmessungen in mm
Dimensions in mm

Weitere Abmessungen auf Anfrage
Further sizes upon request

Ersatzteile

Spare Parts

Einbauhalter Graf Cartridge Graf	Höhenverstellungsschraube Screw to adjust the height	Kühlmittelanschluss Coolant supply	Spannelement Clamping element
L.6...	002.00.69	004.00.19	4.082L
R.6..	002.00.69	004.00.19	4.081R

G

Einstecken und Drehen

Grooving and Turning



Einbauhalter Graf

Cartridge Graf

64/65/99

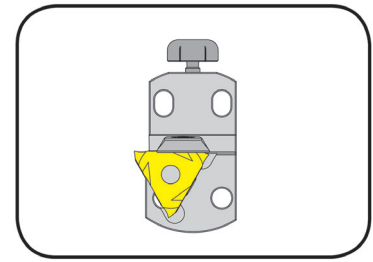

Stechtiefe
Spannbereich

Depth of groove
Clamping range

4 mm
0,5-3,9 mm

für Wendeschneidplatte
for Indexable insert

Typ 312
Type S312
N312

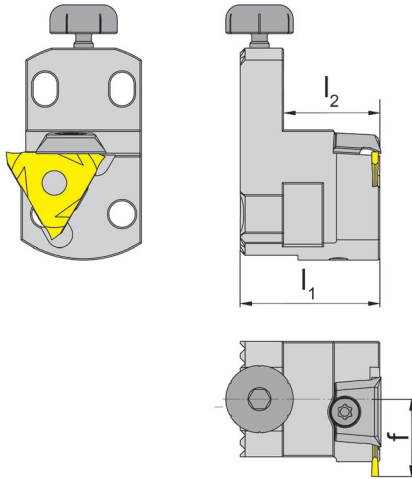

R = rechts wie gezeichnet
R = right hand version shown

L = links spiegelbildlich
L = left hand version

Bestellnummer Part number	l_1	l_2	f	Größe Size	Spannbereich Clamping range
R/L.64	29	20	16	01	0,5-1,9
R/L.65	29	20	16	02	1,9-2,9
R/L99	29	20	16	03	2,9-3,9

Ausführung R oder L angeben
State R or L version

Weitere Abmessungen auf Anfrage
Further sizes upon request

Abmessungen in mm
Dimensions in mm

G

Ersatzteile

Spare Parts

Einbauhalter Graf Cartridge Graf	Höhenverstellungsschraube Screw to adjust the height	Spannelement Clamping element
R/L6.../99	002.00.69	12.3

Einstecken und Drehen

Grooving and Turning



Einstellbare Halter

Adjustable holder

N67/N68/N98

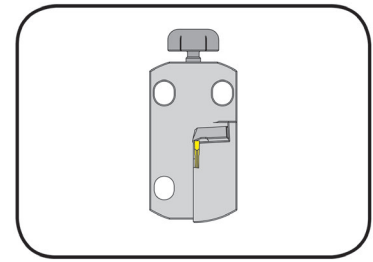

Stechtiefe Spannbereich	Depth of groove Clamping range	4 mm 0,5-3,9 mm
----------------------------	-----------------------------------	--------------------

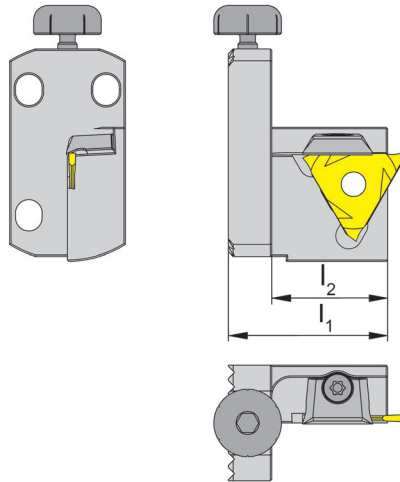

für Wendeschneidplatte
for Indexable insert

Typ 312
Type S312
N312

Bestellnummer Part number	l_1	l_2	Größe Size	Spannbereich Clamping range
N.67	33	29	01	0,5-1,9
N.68	33	29	02	1,9-2,9
N98	33	29	02	2,9-3,9

Weitere Abmessungen auf Anfrage
Further sizes upon request

Abmessungen in mm
Dimensions in mm

Ersatzteile

Spare Parts

Einstellbare Halter Adjustable holder	Höhenverstellungsschraube Screw to adjust the height	Spannelement Clamping element
N.67	002.00.69	12.3

G

Einstechen und Abstechen

Grooving and Parting Off



Wendeschneidplatte

Indexable insert

S312

mit gesinterter Geometrie
with sintered geometries

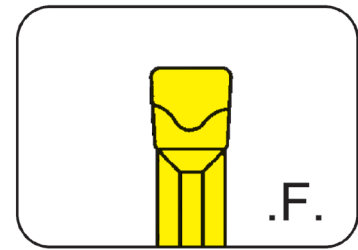

Stechbreite Width of groove 2-5 mm

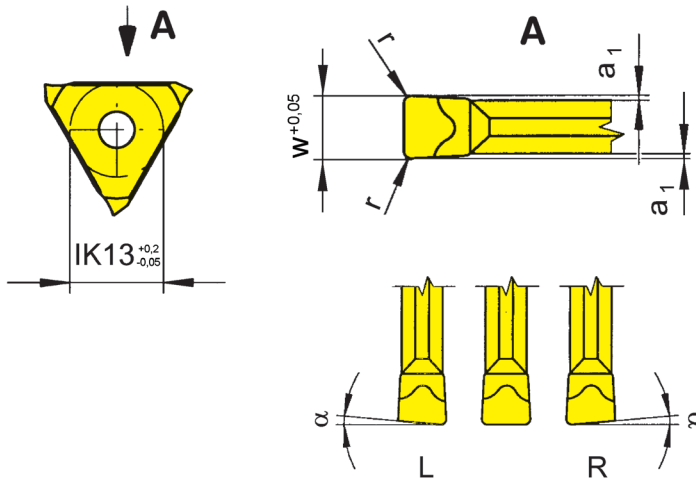

R = rechts wie gezeichnet
R = right hand version shown

L = links spiegelbildlich
L = left hand version

für Klemmhalter
for Toolholder

Typ 360
Type 361
368
369
391
64/65/99
N67/N68/N98

Geometrie .F
Geometry .F

Bestellnummer Part number	w	r	α	a_1	Größe Size	AL96	EG56	TC92	TF45	TF46	TI25
R/LS312.0520.F2	2,0	0,2	5°	0,25	02		Δ/Δ			▲/Δ	▲/▲
S312.0200.F2	2,0	0,2	0°	0,25	02	Δ	▲	Δ	Δ	▲	▲
R/LS312.0525.F2	2,5	0,2	5°	0,25	02		▲/Δ			▲/Δ	▲/▲
S312.0250.F2	2,5	0,2	0°	0,25	02	Δ	Δ	Δ	Δ	▲	▲
S312.0400.F2	4,0	0,2	0°	0,25	04		Δ			▲	Δ
S312.0400.F4	4,0	0,4	0°	0,25	04		▲			▲	▲
S312.0500.F2	5,0	0,2	0°	0,25	04		▲			▲	
S312.0500.F4	5,0	0,4	0°	0,25	04		Δ			Δ	

▲ ab Lager / on stock Δ 4 Wochen / 4 weeks x auf Anfrage / upon request

● empfohlen / recommended

o bedingt einsetzbar / alternative recommendation

- nicht geeignet / not suitable

■ unbeschichtete HM-Sorten / uncoated grades

■ beschichtete HM-Sorten / coated grades

■ bestückt/Cermet / brazed/Cermet

Abmessungen in mm

Dimensions in mm

Ausführung R oder L angeben

State R or L version

Wendeschneidplatten sind in rechten und linken Klemmhaltern verwendbar.

Indexable inserts can be used in right and left hand toolholders.

P	●	●	●	●	●	●
M	-	o	-	●	o	●
K	●	o	-	●	●	●
N	●	-	-	●	●	●
S	-	-	-	●	o	●
H	-	-	-	-	-	-

HM-Sorten
Carbide grades

G

Einstecken (außen und innen)

Grooving (external and internal)



Wendeschneidplatte

Indexable insert

S312

mit gesinterter Geometrie
with sintered geometries

Stechbreite	Width of groove	2,5-3 mm
-------------	-----------------	----------

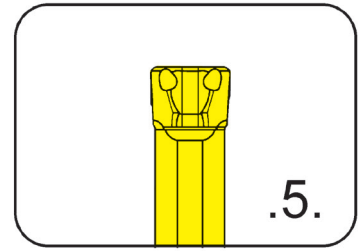

für Klemhalter
for Toolholder

- Typ 360
Type 361
368
369
391
64/65/99
N67/N68/N98

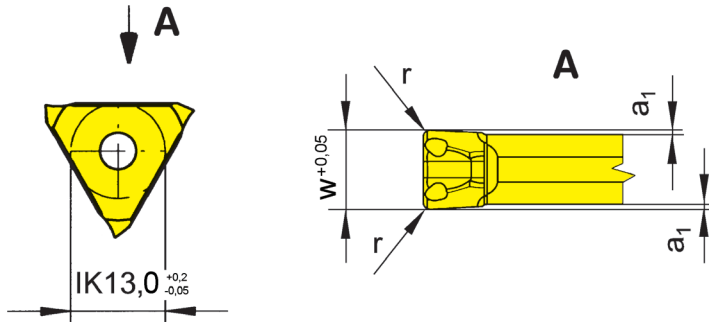

Geometrie .5
Geometry .5

Bestellnummer Part number	w	r	a ₁	Größe Size	AL96	AS62	AS66	EG56	TC92	TF45	TF46	TI25	TN32	TN35
S312.0250.52	2,5	0,2	0,25	02	▲	▲	▲	▲	△	▲	▲	▲	▲	▲
S312.0250.54	2,5	0,4	0,25	02	△	▲	▲	▲	△	▲	▲	▲	▲	▲
S312.0300.52	3,0	0,2	0,25	03	△	▲	▲	▲	△	▲	▲	▲	▲	▲
S312.0300.54	3,0	0,4	0,25	03	△	▲	▲	▲	△	▲	▲	▲	▲	▲
▲ ab Lager / on stock △ 4 Wochen / 4 weeks x auf Anfrage / upon request					P	•	•	•	•	•	•	•	•	•
● empfohlen / recommended					M	-	-	o	o	-	•	o	•	-
o bedingt einsetzbar / alternative recommendation					K	•	-	•	o	-	•	•	-	•
- nicht geeignet / not suitable					N	•	-	•	-	-	•	•	-	•
■ unbeschichtete HM-Sorten / uncoated grades					S	-	-	o	-	-	o	•	-	•
■ beschichtete HM-Sorten / coated grades					H	-	-	-	-	-	-	-	-	-
■ bestückt/Cermet / brazed/Cermet														

Abmessungen in mm
Dimensions in mm

Wendeschneidplatten sind in rechten und linken Klemmaltern verwendbar.
Indexable inserts can be used in right and left hand toolholders.

HM-Sorten
Carbide grades



Wendeschneidplatte

Indexable insert

S312

mit gesinterter Geometrie
with sintered geometries

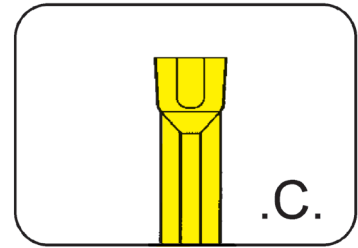

Stechtiefe bis Stechbreite	Depth of groove up to Width of groove	5 mm 2-3 mm
-------------------------------	--	----------------

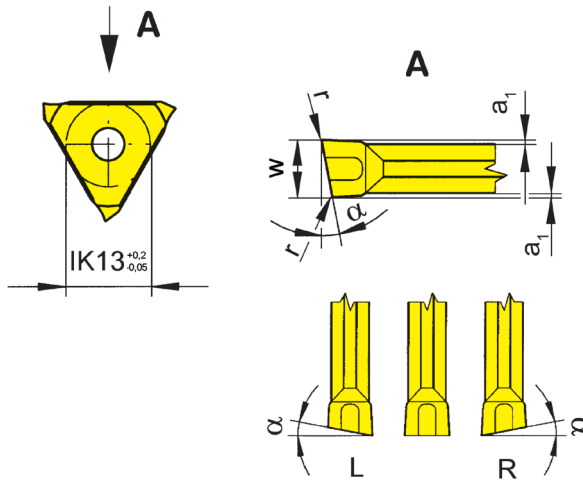

R = rechts wie gezeichnet
R = right hand version shown

L = links spiegelbildlich
L = left hand version

für Klemmhalter
for Toolholder

- Typ 360
Type 361
368
369
391
64/65/99
N67/N68/N98

Geometrie .C
Geometry .C

Bestellnummer Part number	w	r	α	a ₁	Größe Size	EG55	TF46	TI25
S312.0200.C2	2,0	0,2	0°	0,25	02	▲	▲	▲
R/LS312.0520.C2	2,0	0,2	5°	0,25	02	▲/▲	▲/▲	▲/▲
S312.0250.C2	2,5	0,2	0°	0,25	02	▲	Δ	▲
R/LS312.0525.C2	2,5	0,2	5°	0,25	02	Δ/▲	▲/Δ	▲/▲
S312.0300.C2	3,0	0,2	0°	0,25	03	Δ	Δ	Δ
R/LS312.0530.C2	3,0	0,2	5°	0,25	03	Δ/Δ	Δ/Δ	▲/Δ

▲ ab Lager / on stock Δ 4 Wochen / 4 weeks x auf Anfrage / upon request

● empfohlen / recommended

o bedingt einsetzbar / alternative recommendation

- nicht geeignet / not suitable

■ unbeschichtete HM-Sorten / uncoated grades

■ beschichtete HM-Sorten / coated grades

■ bestückt/Cermet / brazed/Cermet

Abmessungen in mm

Dimensions in mm

Ausführung R oder L angeben

State R or L version

Wendeschneidplatten sind in rechten und linken Klemmhaltern verwendbar.

Indexable inserts can be used in right and left hand toolholders.

	P	M	K	N	S	H
EG55	●	●	●	-	-	-
TF46	●	○	●	●	○	-
TI25	●	●	●	●	●	-

HM-Sorten
Carbide grades

G

Einstechen und Abstechen

Grooving and Parting Off



Wendeschneidplatte

Indexable insert

S312

mit gesinterter Geometrie
with sintered geometries

Stechbreite	Width of groove	2-3 mm
-------------	-----------------	--------

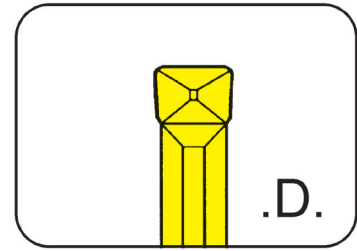

für Klemmhalter
for Toolholder

- Typ 360
Type 361
368
369
391
64/65/99
N67/N68/N98

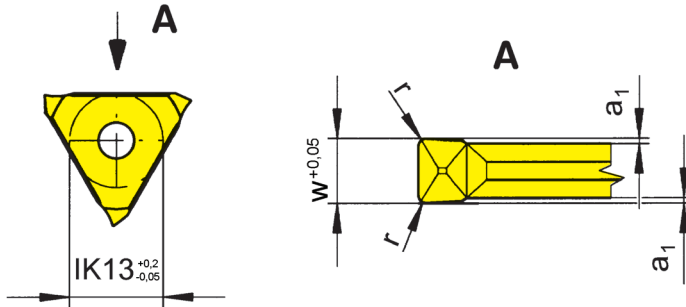

Geometrie .D
Geometry .D

Bestellnummer Part number	w	r	a ₁	Größe Size	AL96	AS62	AS66	EG56	TC92	TF45	TF46	Ti25	TN32
S312.0200.D2	2,0	0,2	0,25	02	▲	▲	▲	▲	▲	▲	▲	▲	▲
S312.0200.D4	2,0	0,4	0,25	02	▲	▲	▲	▲	▲	▲	▲	▲	▲
S312.0250.D2	2,5	0,2	0,25	02	▲	▲	▲	▲	▲	▲	▲	▲	▲
S312.0250.D4	2,5	0,4	0,25	02	▲	▲	▲	▲	▲	▲	▲	▲	▲
S312.0300.D2	3,0	0,2	0,25	03	▲	▲	▲	▲	▲	▲	▲	▲	▲
S312.0300.D4	3,0	0,4	0,25	03	▲	▲	▲	▲	▲	▲	▲	▲	▲
▲ ab Lager / on stock Δ 4 Wochen / 4 weeks x auf Anfrage / upon request					P	●	●	●	●	●	●	●	●
● empfohlen / recommended					M	-	-	o	o	-	●	o	-
o bedingt einsetzbar / alternative recommendation					K	●	-	●	o	-	●	●	-
- nicht geeignet / not suitable					N	●	-	●	-	-	●	●	-
■ unbeschichtete HM-Sorten / uncoated grades					S	-	-	o	-	-	●	o	-
■ beschichtete HM-Sorten / coated grades					H	-	-	-	-	-	-	-	-
■ bestückt/Cermet / brazed/Cermet													

Abmessungen in mm
Dimensions in mm

Wendeschneidplatten sind in rechten und linken Klemmhaltern verwendbar.
Indexable inserts can be used in right and left hand toolholders.

HM-Sorten
Carbide grades



Einstecken (außen)

Grooving (external)



Wendeschneidplatte

Indexable insert

312

mit runder Spanleitstufe
with round chip breaker

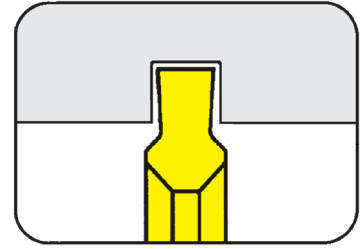

Seegerringnuten
Nutnennbreite Nw

Circlip grooves
Width of circlip Nw

DIN 471/472
0,5-1 mm

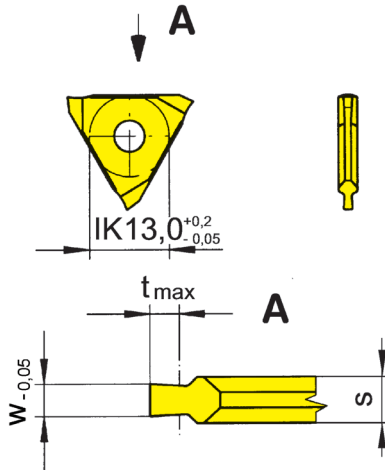

für Klemmhalter
for Toolholder

Typ 360
Type 361
368
369
391
64/65/99
N67/N68/N98

Wechselgenauigkeit
Länge $\pm 0,02$ mm
Indexability length $\pm 0,02$ mm

Bestellnummer Part number	w	Nw	t _{max}	s	Größe Size	EG52	TN32
312.0050.15	0,57	0,5	0,7	1,5	01	▲	▲
312.0060.15	0,67	0,6	0,8	1,5	01	▲	▲
312.0070.15	0,77	0,7	1,1	1,5	01	▲	▲
312.0080.15	0,87	0,8	1,2	1,5	01	▲	▲
312.0090.15	0,97	0,9	1,4	1,5	01	▲	▲
312.0100.15	1,07	1,0	1,6	1,5	01	▲	▲

▲ ab Lager / on stock Δ 4 Wochen / 4 weeks x auf Anfrage / upon request

● empfohlen / recommended

o bedingt einsetzbar / alternative recommendation

- nicht geeignet / not suitable

□ unbeschichtete HM-Sorten / uncoated grades

■ beschichtete HM-Sorten / coated grades

■ bestückt/Cermet / brazed/Cermet

Abmessungen in mm

Dimensions in mm

Wendeschneidplatten sind in rechten und linken Klemmhaltern verwendbar.

Indexable inserts can be used in right and left hand toolholders.

Weitere Abmessungen auf Anfrage

Further sizes upon request

P	●	●
M	○	-
K	-	-
N	-	-
S	-	-
H	-	-

HM-Sorten
Carbide grades

G

Einstechen (außen und innen)

Grooving (external and internal)



Wendeschneidplatte

Indexable insert

312

mit runder Spanleitstufe
with round chip breaker

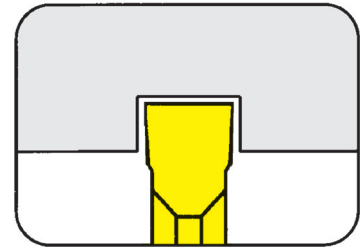

Seegerringnuten
Nutnennbreite Nw

Circlip grooves
Width of circlip Nw

DIN 471/472
0,5-5,15 mm

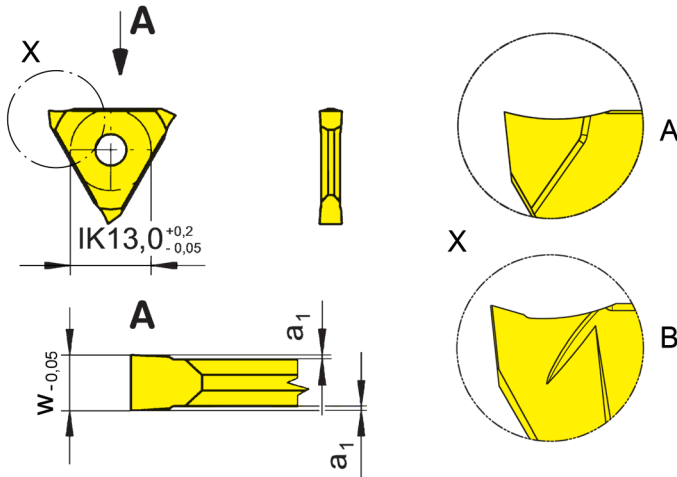

Form A = komplett geschliffen
Form A = completely ground

Form B = teilgeschliffen
Form B = partially ground

für Klemmhalter
for Toolholder

Typ 360
Type 361
368
369
391
64/65/99
N67/N68/N98

Wechselgenauigkeit
Länge ± 0,02 mm
Indexability length ± 0,02 mm

Bestellnummer Part number	w	Nw	a ₁	Form Form	Größe Size	K10	MG12	EG35	EG55	EG56	H20	HS32	HS36	P20	TA45	TC92	TF45	TF46	TI25	TN32	TN35
312.0050.00	0,57	0,50	0,07	A	01	▲			▲					▲			▲	▲		▲	
312.0060.00	0,67	0,60	0,07	A	01	▲			▲					▲			▲	▲		▲	
312.0070.00	0,77	0,70	0,08	A	01	▲			▲					▲			▲	▲		▲	
312.0080.00	0,87	0,80	0,08	A	01	▲			▲					▲			▲	▲		▲	
312.0090.00	0,97	0,90	0,08	A	01	▲			▲					▲			▲	▲		▲	▲
312.0100.00	1,07	1,00	0,09	A	01	▲			▲		Δ			▲			▲	▲		▲	▲
312.0110.00	1,24	1,10	0,20	A	01	▲			▲			Δ	Δ	▲		▲	▲	▲		▲	▲
312.0130.00	1,44	1,30	0,20	A	01	▲			▲					▲		▲	▲	▲		▲	▲
312.0160.00	1,74	1,60	0,20	A	01	▲			▲					▲		▲	▲	▲		▲	▲
312.0185.00	1,99	1,85	0,20	B	01	▲	▲		▲	Δ	▲			▲		▲	▲	▲	▲	▲	▲
312.0215.00	2,29	2,15	0,20	B	02	▲	▲		▲		▲			▲	▲	▲	▲	▲		▲	▲
312.0265.00	2,79	2,65	0,20	B	02	▲	▲		▲		▲			▲	Δ	▲	▲	▲		▲	▲
312.0315.00	3,29	3,15	0,20	B	03	▲			▲		▲			▲		▲	▲	▲		▲	▲
312.0415.00	4,29	4,15	0,20	B	04	▲			▲		▲			▲		▲	▲	▲		▲	▲
312.0515.00	5,29	5,15	0,20	B	04	▲			▲		Δ			▲		Δ	▲	▲		▲	▲

- ▲ ab Lager / on stock Δ 4 Wochen / 4 weeks
- x auf Anfrage / upon request
- empfohlen / recommended
- bedingt einsetzbar / alternative recommendation
- nicht geeignet / not suitable
- unbeschichtete HM-Sorten / uncoated grades
- beschichtete HM-Sorten / coated grades
- bestückt/Cermet / brazed/Cermet

P	●	○	●	●	●	○	-	●	●	●	●	●	●	●	●	●	●	●	●	●	●
M	○	●	●	○	○	○	-	-	●	-	●	-	●	○	○	○	○	○	○	○	○
K	●	●	○	○	○	-	-	-	-	-	-	-	-	-	-	-	-	-	-	-	-
N	●	●	-	-	-	-	-	-	-	-	-	-	-	-	-	-	-	-	-	-	-
S	○	●	-	-	-	-	-	-	-	-	-	-	-	-	-	-	-	-	-	-	-
H	-	-	-	-	-	-	-	-	-	-	-	-	-	-	-	-	-	-	-	-	-

Abmessungen in mm
Dimensions in mm

HM-Sorten
Carbide grades

Wendeschneidplatten sind in rechten und linken Klemmhaltern verwendbar.
Indexable inserts can be used in right and left hand toolholders.



Einstecken (außen und innen)

Grooving (external and internal)



Wendeschneidplatte

Indexable insert

312

mit runder Spanleitstufe
with round chip breaker

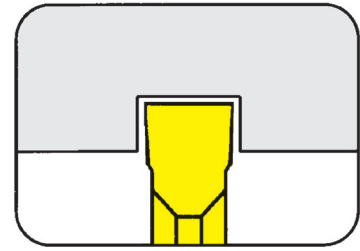

Seegerringnuten
Nutnennbreite Nw

Circlip grooves
Width of circlip Nw

DIN 471/472
1,85-5,15 mm

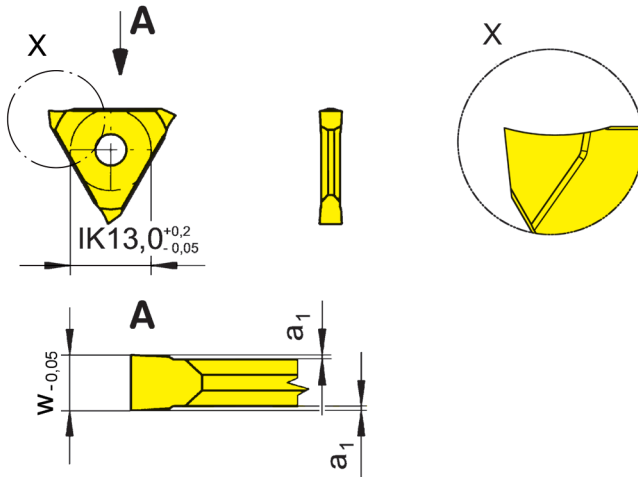

komplett geschliffen
completely ground

für Klemmhalter
for Toolholder

Typ 360
Type 361
368
369
391
64/65/99
N67/N68/N98

Wechselgenauigkeit
Länge $\pm 0,02$ mm
Indexability length $\pm 0,02$ mm

Bestellnummer Part number	w	Nw	a ₁	Größe Size	K10	P20	EG56	TN32
312.0185.10	1,99	1,85	0,2	01	▲	▲	▲	▲
312.0215.10	2,29	2,15	0,2	02	▲	▲	▲	▲
312.0265.10	2,79	2,65	0,2	02	▲	▲	▲	▲
312.0315.10	3,29	3,15	0,2	03	▲	▲	▲	▲
312.0415.10	4,29	4,15	0,2	04	▲	▲	▲	▲
312.0515.10	5,29	5,15	0,2	04	▲	▲	▲	▲

▲ ab Lager / on stock Δ 4 Wochen / 4 weeks x auf Anfrage / upon request

● empfohlen / recommended

o bedingt einsetzbar / alternative recommendation

- nicht geeignet / not suitable

□ unbeschichtete HM-Sorten / uncoated grades

■ beschichtete HM-Sorten / coated grades

■ bestückt/Cermet / brazed/Cermet

Abmessungen in mm

Dimensions in mm

Wendeschneidplatten sind in rechten und linken Klemmhaltern verwendbar.

Indexable inserts can be used in right and left hand toolholders.

	P	M	K	N	S	H
K10	●	○	●	●	○	-
P20	●	-	○	-	-	-
EG56	●	○	○	-	-	-
TN32	●	-	-	-	-	-

HM-Sorten
Carbide grades

G

Einstecken (außen)

Grooving (external)



Wendeschneidplatte

Indexable insert

312

mit runder Spanleitstufe
with round chip breaker

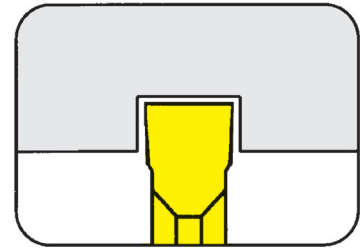

Seegerringnuten
Nutnennbreite Nw

Circlip grooves
Width of circlip Nw

DIN 471/472
1,1-5,15 mm

besonders geeignet für unterbrochenen Schnitt
recommended for interrupted cut

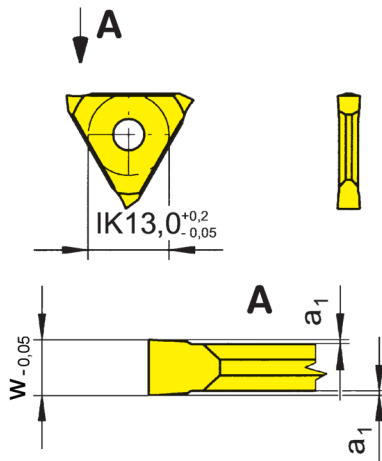

für Klemmhalter
for Toolholder

Typ 360
Type 361
368
369
391
64/65/99
N67/N68/N98

Wechselgenauigkeit
Länge $\pm 0,02$ mm
Indexability length $\pm 0,02$ mm

Bestellnummer Part number	w	Nw	a ₁	Größe Size	EG55	TN35
312.0110.80	1,24	1,10	0,2	01	▲	▲
312.0130.80	1,44	1,30	0,2	01	▲	▲
312.0160.80	1,74	1,60	0,2	01	▲	▲
312.0185.80	1,99	1,85	0,2	01	▲	▲
312.0215.80	2,29	2,15	0,2	02	▲	▲
312.0265.80	2,79	2,65	0,2	02	▲	▲
312.0315.80	3,29	3,15	0,2	03	▲	▲
312.0415.80	4,29	4,15	0,2	04	▲	▲
312.0515.80	5,29	5,15	0,2	04	▲	▲

▲ ab Lager / on stock Δ 4 Wochen / 4 weeks x auf Anfrage / upon request

● empfohlen / recommended

o bedingt einsetzbar / alternative recommendation

- nicht geeignet / not suitable

■ unbeschichtete HM-Sorten / uncoated grades

■ beschichtete HM-Sorten / coated grades

■ bestückt/Cermet / brazed/Cermet

Abmessungen in mm

Dimensions in mm

Wendeschneidplatten sind in rechten und linken Klemmhaltern verwendbar.

Indexable inserts can be used in right and left hand toolholders.

P	●	●
M	o	●
K	o	●
N	-	●
S	-	●
H	-	-

HM-Sorten
Carbide grades

G

Einstechen (außen und innen)

Grooving (external and internal)



Wendeschneidplatte

Indexable insert

312

mit runder Spanleitstufe
with round chip breaker

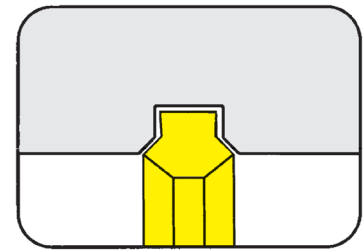

Seegerringnuten
Nutnennbreite Nw

Circlip grooves
Width of circlip Nw

DIN 471/472
1,1-5,15 mm

mit Nutaußenkantenfasung
with chamfer

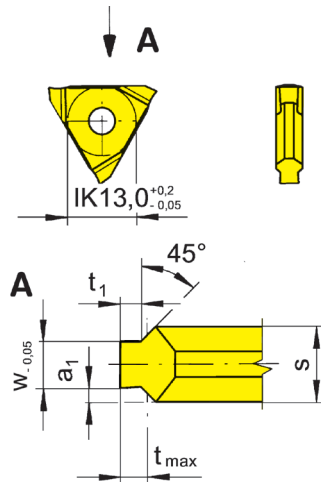

für Klemmhalter
for Toolholder

Typ 360
Type 361
368
369
391
64/65/99
N67/N68/N98

Wechselgenauigkeit
Länge ± 0,02 mm
Indexability length ± 0,02 mm

Bestellnummer Part number	w	Nw	t _{max}	a ₁	s	t ₁	Größe Size	P20	EG52	TN32	TN35
312.1101.25	1,24	1,10	0,20	0,64	2,5	0,19	02		Δ	Δ	
312.1102.25	1,24	1,10	0,25	0,64	2,5	0,24	02		▲	▲	
312.1103.25	1,24	1,10	0,30	0,64	2,5	0,29	02		▲	▲	
312.1104.25	1,24	1,10	0,35	0,64	2,5	0,33	02		Δ	▲	
312.1105.25	1,24	1,10	0,40	0,64	2,5	0,36	02	▲	▲	▲	Δ
312.1306.25	1,44	1,30	0,55	0,54	2,5	0,45	02	Δ	▲	▲	
312.1607.33	1,74	1,60	0,70	0,79	3,3	0,60	03		▲	▲	
312.1608.33	1,74	1,60	0,85	0,79	3,3	0,75	03	Δ	▲	▲	
312.1609.33	1,74	1,60	1,00	0,79	3,3	0,85	03		▲	▲	
312.1810.33	1,99	1,85	1,00	0,67	3,3	0,85	03		▲	▲	
312.1812.33	1,99	1,85	1,25	0,67	3,3	1,10	03	Δ	▲	▲	
312.2115.43	2,29	2,15	1,50	1,02	4,3	1,35	04	▲	▲	▲	
312.2616.43	2,79	2,65	1,50	0,77	4,3	1,35	04	Δ	▲	▲	
312.2617.43	2,79	2,65	1,75	0,77	4,3	1,60	04	Δ	▲	▲	
312.3118.53	3,29	3,15	1,75	1,02	5,3	1,60	04	Δ	▲	▲	
312.4120.53	4,29	4,15	2,00	0,52	5,3	1,85	04		▲	▲	
312.4125.53	4,29	4,15	2,50	0,52	5,3	2,35	04		Δ	▲	
312.5130.63	5,29	5,15	3,00	0,52	6,3	2,85	04		Δ	▲	

▲ ab Lager / on stock Δ 4 Wochen / 4 weeks x auf Anfrage / upon request

● empfohlen / recommended

○ bedingt einsetzbar / alternative recommendation

- nicht geeignet / not suitable

■ unbeschichtete HM-Sorten / uncoated grades

■ beschichtete HM-Sorten / coated grades

■ bestückt/Cermet / brazed/Cermet

Abmessungen in mm

Dimensions in mm

Wendeschneidplatten sind in rechten und linken Klemmhaltern verwendbar.

	P	M	K	N	S	H
P	●	●	●	●	●	●
M	-	○	-	-	●	-
K	-	-	-	-	●	-
N	-	-	-	-	●	-
S	-	-	-	-	●	-
H	-	-	-	-	-	-

HM-Sorten
Carbide grades

NC-Universaldrehplatte

Finishing on NC-Lathes



Wendeschneidplatte

Indexable insert

312

mit runder Spanleitstufe
with round chip breaker

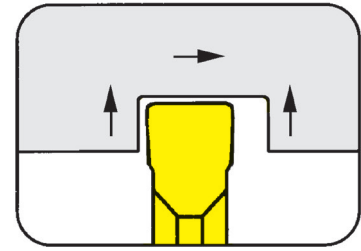

Stechtiefe bis Stechbreite	Depth of groove up to Width of groove	6 mm 1-4 mm
-------------------------------	--	----------------

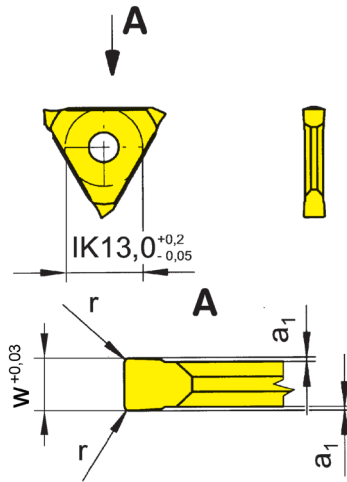

für Klemmhalter
for Toolholder

- Typ 360
Type 361
368
369
391
64/65/99
N67/N68/N98

Wechselgenauigkeit
Länge ± 0,02 mm
Indexability length ± 0,02 mm

Bestellnummer Part number	w	r	a ₁	Größe Size	K10	P20	AS62	EG52	TF45	TI22	TI25	TN32	TN35	TN38	H20
312.0100.02	1,0	0,2	0,10	01				▲			▲	▲			
312.0150.02	1,5	0,2	0,25	01	Δ	▲		▲			▲	▲	▲		
312.0200.02	2,0	0,2	0,25	02	▲	▲		▲	▲	▲	▲	▲	▲		▲
312.0200.04	2,0	0,4	0,25	02		▲	▲	▲			▲	▲			▲
312.0300.02	3,0	0,2	0,25	03	Δ	▲		▲			▲	▲			▲
312.0300.06	3,0	0,6	0,25	03		▲		▲			▲	▲			▲
312.0300.08	3,0	0,8	0,25	03		Δ		▲			▲	▲		Δ	▲
312.0400.02	4,0	0,2	0,25	04		▲		▲			▲	▲			▲
312.0400.08	4,0	0,8	0,25	04		Δ		▲			▲	▲			▲
312.0400.12	4,0	1,2	0,25	04		Δ		Δ							
▲ ab Lager / on stock Δ 4 Wochen / 4 weeks x auf Anfrage / upon request															
● empfohlen / recommended															
○ bedingt einsetzbar / alternative recommendation															
- nicht geeignet / not suitable															
■ unbeschichtete HM-Sorten / uncoated grades															
■ beschichtete HM-Sorten / coated grades															
■ bestückt/Cermet / brazed/Cermet															
Abmessungen in mm Dimensions in mm															
Wendeschneidplatten sind in rechten und linken Klemmhaltern verwendbar. Indexable inserts can be used in right and left hand toolholders.															

HM-Sorten
Carbide grades



Einstecken und Längsdrehen

Grooving and Side Turning



Wendeschneidplatte

Indexable insert

312

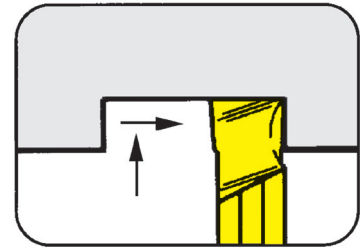

Schnitttiefe bis	Depth of cut up to	3,5 mm
------------------	--------------------	--------

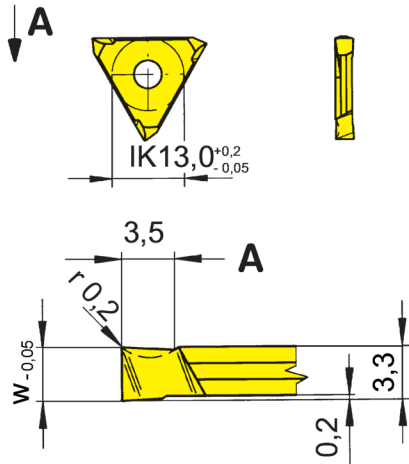

für Klemmhalter
for Toolholder

- Typ 360
Type 361
368
369
391
64/65/99
N67/N68/N98

Wechselgenauigkeit
Länge ± 0,02 mm
Indexability length ± 0,02 mm

L = links wie gezeichnet
L = left hand version shown

R = rechts spiegelbildlich
R = right hand version

Bestellnummer Part number	w	Größe Size		P20	EG52	TC92	TN32
R/L312.3031.33	3,29	03		▲/△	▲/▲	△/△	▲/▲
▲ ab Lager / on stock △ 4 Wochen / 4 weeks x auf Anfrage / upon request			P	•	•	•	•
● empfohlen / recommended			M	-	o	-	-
o bedingt einsetzbar / alternative recommendation			K	-	-	-	-
- nicht geeignet / not suitable			N	-	-	-	-
■ unbeschichtete HM-Sorten / uncoated grades			S	-	-	-	-
■ beschichtete HM-Sorten / coated grades			H	-	-	-	-
■ bestückt/Cermet / brazed/Cermet							

Abmessungen in mm
Dimensions in mm

Ausführung R oder L angeben
State R or L version

Wendeschneidplatten sind in rechten und linken Klemmhaltern verwendbar.
Indexable inserts can be used in right and left hand toolholders.

Die besondere Schneidengeometrie erlaubt unter Beibehaltung einer geraden und rechtwinkligen Hauptschneide sowohl in radialer als auch in axialer Richtung positive Spanwinkel.

The special cutting geometry permits a positive chip breaking angle when keeping a straight and right angled cutting edge.

HM-Sorten
Carbide grades

G

Einstecken/Profildrehen (Vollradius)

Grooving and Profiling (Full radius)



Wendeschneidplatte

Indexable insert

312

mit runder Spanleitstufe
with round chip breaker

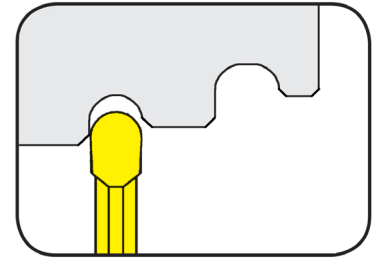

Stechtiefe bis
Vollradius

Depth of groove up to
Full radius

6 mm
0,25-2 mm

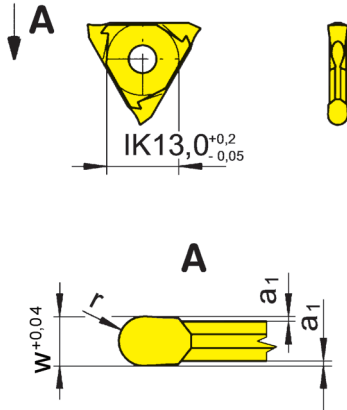

für Klemhalter
for Toolholder

Typ 360
Type 361
368
369
391
64/65/99
N67/N68/N98

Wechselgenauigkeit
Länge $\pm 0,02$ mm
Indexability length $\pm 0,02$ mm

Bestellnummer Part number	w	a ₁	r	Größe Size	P20	AS45	EG35	EG55	TF45	TH35	TI25	TN32	TN35
312.0050.02	0,5	0,07	0,25	01	▲	▲	▲					▲	
312.0100.05	1,0	0,09	0,50	01	▲	▲	▲			Δ		▲	Δ
312.0110.05	1,1	0,09	0,55	01		▲		Δ					
312.0120.06	1,2	0,20	0,60	01	▲	▲		▲				▲	
312.0140.07	1,4	0,20	0,70	01		▲		▲					
312.0160.08	1,6	0,25	0,80	01	▲	▲		▲				▲	
312.0180.09	1,8	0,25	0,90	01		▲		▲					
312.0200.10	2,0	0,25	1,00	01	▲	▲		▲	Δ		Δ	▲	
312.0220.11	2,2	0,25	1,10	02		▲		▲					
312.0250.12	2,5	0,25	1,25	02	▲	▲		Δ				▲	
312.0280.14	2,8	0,25	1,40	02		▲		Δ					
312.0300.15	3,0	0,25	1,50	02	▲	▲		▲				▲	
312.0360.18	3,6	0,25	1,80	03		▲		Δ					
312.0400.20	4,0	0,25	2,00	03	▲	▲		Δ				▲	
312.0400.20	4,0	0,25	2,00	03	▲	▲		Δ				▲	

- ▲ ab Lager / on stock Δ 4 Wochen / 4 weeks x auf Anfrage / upon request
- empfohlen / recommended
- o bedingt einsetzbar / alternative recommendation
- nicht geeignet / not suitable
- unbeschichtete HM-Sorten / uncoated grades
- beschichtete HM-Sorten / coated grades
- bestückt/Cermet / brazed/Cermet

Weitere Radien auf Anfrage
Further radii upon request

Abmessungen in mm
Dimensions in mm

HM-Sorten
Carbide grades

Bearbeitungshinweis:

Nutbreiten bis 1,6 mm nur zum Nutzenstechdrehen empfohlen

Note:

Width of groove up to 1,6 mm recommend only for grooving

G

Einstechen (außen)

Grooving (external)



Wendeschneidplatte

Indexable insert

312

mit runder Spanleitstufe
with round chip breaker

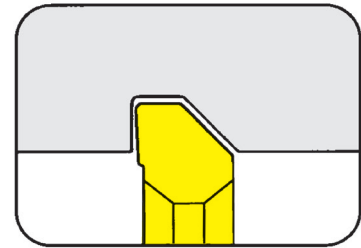

Gewindfreistriche DIN 76 „Kurzausführung“
Thread relief DIN 76 „Short form“

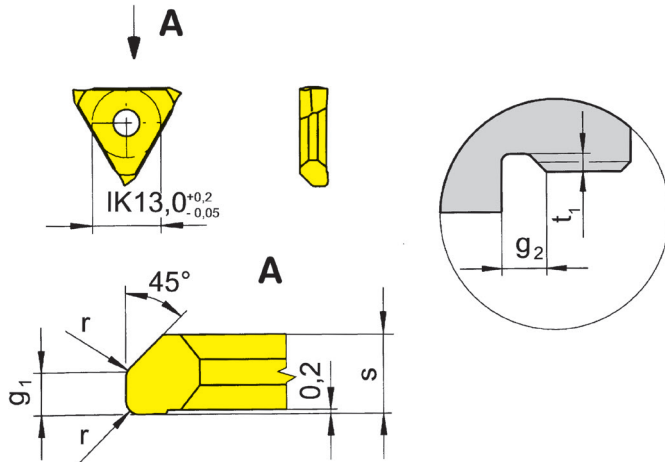

für Klemmhalter
for Toolholder

Typ 360
Type 361
368
369
391
64/65/99
N67/N68/N98

R = rechts wie gezeichnet
R = right hand version shown

L = links spiegelbildlich
L = left hand version

Wechselgenauigkeit
Länge ± 0,02 mm
Indexability length ± 0,02 mm

Bestellnummer Part number	P	r	t ₁	s	g ₁	g ₂	Größe Size	P20	EG55	TN35
R/L312.1050.17	0,50	0,2	0,40	1,7	0,60	1,0	01	▲/▲	▲/▲	▲/▲
R/L312.1060.17	0,60	0,4	0,50	1,7	0,70	1,2	01	▲/▲	▲/▲	▲/▲
R/L312.1070.17	0,70	0,4	0,55	1,7	0,85	1,4	01	▲/▲	▲/▲	▲/▲
R/L312.1080.27	0,80	0,4	0,65	2,7	0,95	1,6	02	▲/▲	▲/▲	▲/▲
R/L312.1100.27	1,00	0,6	0,80	2,7	1,20	2,0	02	▲/▲	▲/▲	▲/▲
R/L312.1125.27	1,25	0,6	1,00	2,7	1,50	2,5	02	▲/▲	▲/▲	▲/▲
R/L312.1150.37	1,50	0,8	1,15	3,7	1,85	3,0	03	▲/▲	▲/▲	▲/▲
R/L312.1175.37	1,75	1,0	1,30	3,7	2,20	3,5	03	▲/▲	▲/▲	▲/▲
R/L312.1200.53	2,00	1,0	1,50	5,3	2,50	4,0	04	▲/▲	▲/▲	▲/▲
R/L312.1250.53	2,50	1,2	1,80	5,3	3,20	5,0	04	▲/▲	▲/▲	▲/▲
R/L312.1300.63	3,00	1,6	2,20	6,3	3,80	6,0	04	▲/▲	▲/▲	▲/▲

▲ ab Lager / on stock Δ 4 Wochen / 4 weeks x auf Anfrage / upon request

● empfohlen / recommended

o bedingt einsetzbar / alternative recommendation

- nicht geeignet / not suitable

■ unbeschichtete HM-Sorten / uncoated grades

■ beschichtete HM-Sorten / coated grades

■ bestückt/Cermet / brazed/Cermet

Abmessungen in mm

Dimensions in mm

Ausführung R oder L angeben

State R or L version

Rechte WSP in rechten, linke WSP in linken Klemmhaltern verwenden.

Use right hand inserts in right hand toolholders and left hand inserts in left hand toolholders

P	●	●	●
M	-	○	●
K	-	○	●
N	-	-	●
S	-	-	●
H	-	-	-

HM-Sorten
Carbide grades

G

Einstecken (außen)

Grooving (external)



Wendeschneidplatte

Indexable insert

312

mit runder Spanleitstufe
with round chip breaker

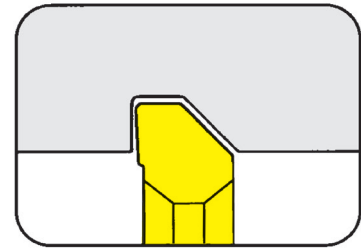

Gewindereifstiche DIN 76 „Regelausführung“
Thread relief DIN 76 „Standard form“

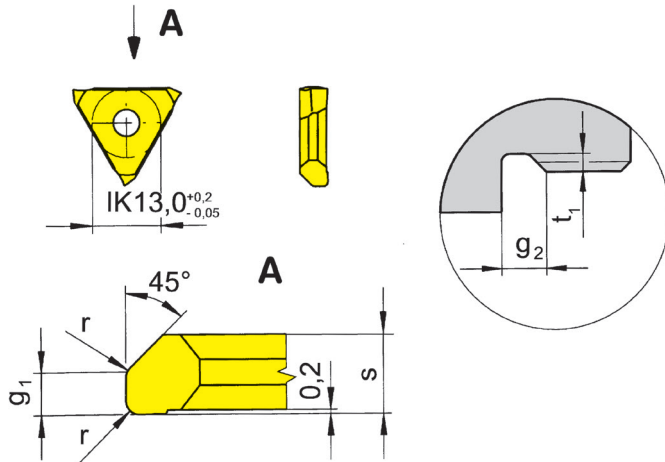

für Klemmhalter
for Toolholder

Typ 360
Type 361
368
369
391
64/65/99
N67/N68/N98

Wechselgenauigkeit
Länge ± 0,02 mm
Indexability length ± 0,02 mm

R = rechts wie gezeichnet
R = right hand version shown

L = links spiegelbildlich
L = left hand version

Bestellnummer Part number	P	r	t ₁	s	g ₁	g ₂	Größe Size	P20	EG55	TN35
R/L312.3050.17	0,50	0,2	0,40	1,7	1,10	1,5	01	x/Δ	Δ/Δ	Δ/Δ
R/L312.3060.27	0,60	0,4	0,50	2,7	1,30	1,8	02	Δ/Δ	▲/▲	▲/Δ
R/L312.3070.27	0,70	0,4	0,55	2,7	1,55	2,1	02	Δ/Δ	Δ/Δ	Δ/Δ
R/L312.3080.27	0,80	0,4	0,65	2,7	1,75	2,4	02	Δ/Δ	Δ/Δ	Δ/Δ
R/L312.3100.37	1,00	0,6	0,80	3,7	2,20	3,0	03	Δ/Δ	▲/Δ	▲/Δ
R/L312.3125.53	1,25	0,6	1,00	5,3	2,80	3,8	04	Δ/Δ	Δ/Δ	Δ/Δ
R/L312.3150.53	1,50	0,8	1,15	5,3	3,35	4,5	04	Δ/Δ	▲/Δ	▲/Δ
R/L312.3175.56	1,75	1,0	1,30	5,6	4,00	5,3	04	Δ/Δ	Δ/Δ	Δ/Δ
R/L312.3200.63	2,00	1,0	1,50	6,3	4,50	6,0	04	Δ/Δ	Δ/Δ	Δ/Δ

▲ ab Lager / on stock Δ 4 Wochen / 4 weeks x auf Anfrage / upon request

● empfohlen / recommended

o bedingt einsetzbar / alternative recommendation

- nicht geeignet / not suitable

■ unbeschichtete HM-Sorten / uncoated grades

■ beschichtete HM-Sorten / coated grades

■ bestückt/Cermet / brazed/Cermet

Abmessungen in mm

Dimensions in mm

Ausführung R oder L angeben

State R or L version

Rechte WSP in rechten, linke WSP in linken Klemmhaltern verwenden.

Use right hand inserts in right hand toolholders and left hand inserts in left hand toolholders

P	•	•	•
M	-	o	•
K	-	o	•
N	-	-	•
S	-	-	•
H	-	-	-

HM-Sorten
Carbide grades

G

Einstechen und Abstechen

Grooving and Parting Off



Wendeschneidplatte

Indexable insert

312

mit runder Spanleitstufe
with round chip breaker

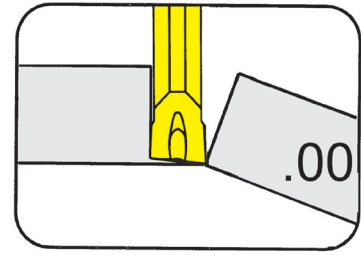

Stechtiefe bis Stechbreite	Depth of groove up to Width of groove	5 mm 1,07-1,44 mm
-------------------------------	--	----------------------

für Klemmhalter
for Toolholder

Typ 360
Type 391

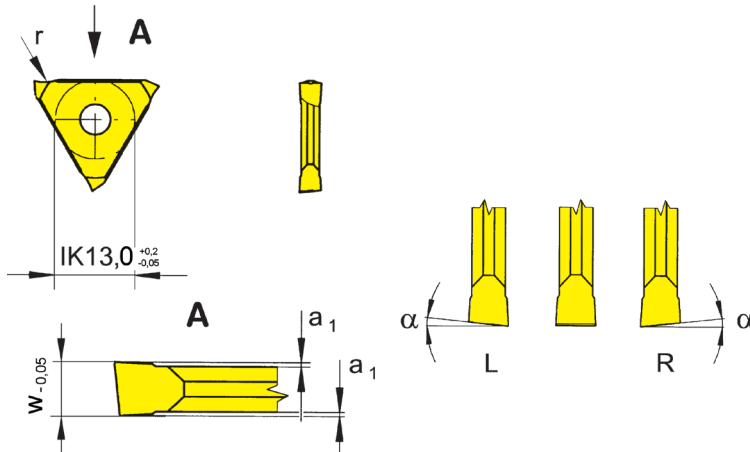

R = rechts wie gezeichnet
R = right hand version shown

L = links spiegelbildlich
L = left hand version

Bestellnummer Part number	w	α	a ₁	Form Form	Größe Size	HM-Sorten														
						K10	P20	EG35	EG55	TC92	TF45	TF46	TI25	TN32	TN35	H20				
312.0100.00	1,07	-	0,09	A	01	▲	▲	■	▲	■	▲	▲	▲	▲	▲	▲	▲	▲	▲	▲
312.0130.00	1,44	-	0,20	A	01	▲	▲	■	▲	■	▲	▲	▲	▲	▲	▲	▲	▲	▲	▲
R/L312.0614.00	1,44	6°	0,20	-	01			▲/▲			▲/▲	▲/▲	▲/▲		▲/▲			▲/▲		
▲ ab Lager / on stock Δ 4 Wochen / 4 weeks x auf Anfrage / upon request						P	●	●	●	●	●	●	●	●	●	●	●	●	●	●
● empfohlen / recommended						M	○	-	○	-	○	○	○	○	○	○	○	○	○	○
○ bedingt einsetzbar / alternative recommendation						K	●	-	○	-	○	○	○	○	○	○	○	○	○	○
- nicht geeignet / not suitable						N	●	-	-	-	-	●	●	●	●	●	●	●	●	●
■ unbeschichtete HM-Sorten / uncoated grades						S	○	-	-	-	-	○	○	○	○	○	○	○	○	○
■ beschichtete HM-Sorten / coated grades						H	-	-	-	-	-	-	-	-	-	-	-	-	-	-
■ bestückt/Cermet / brazed/Cermet																				

Abmessungen in mm
Dimensions in mm

Ausführung R oder L angeben
State R or L version

HM-Sorten
Carbide grades

Außenbearbeitung:

für Klemmhalter Typ 360 rechte WSP in linken, linke WSP in rechten Klemmhaltern verwenden.

External machining:

for Toolholder type 360 use right hand inserts in left hand toolholders and left hand inserts in right hand toolholders

Abstechen von Wellen
parting off solid bars

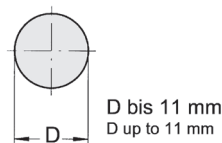

Abstechen von Ringen
parting off tubes

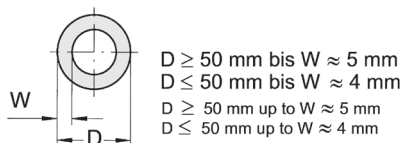

G

Abstechen

Parting Off



Wendeschneidplatte

Indexable insert

312

mit runder Spanleitstufe
with round chip breaker

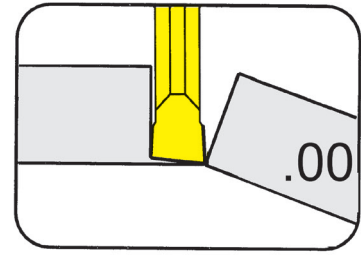

Stechtiefe bis Stechbreite	Depth of groove up to Width of groove	8 mm 0,5-1,5 mm
-------------------------------	--	--------------------

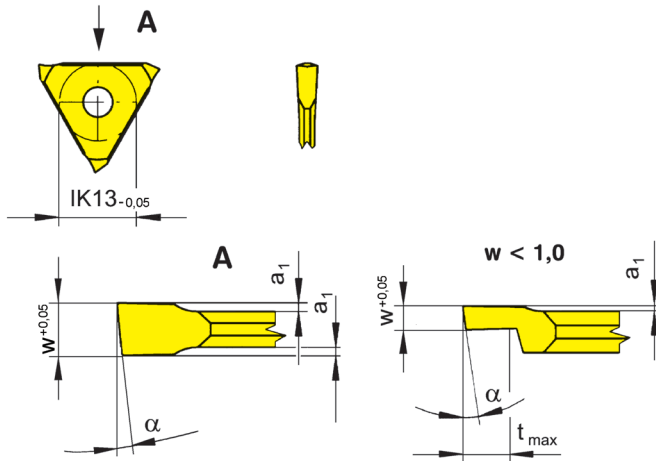

für Klemhalter
for Toolholder

- Typ 360
Type 361
368
369
391
64/65/99
N67/N68/N98

R = rechts wie gezeichnet
R = right hand version shown

L = links spiegelbildlich
L = left hand version

Bestellnummer Part number	w	t _{max}	α	a ₁	Größe Size	K10	P20	EG35	EG55	TC92	TF45	TF46	TI25	TN32	TN35	H20
R/L312.0805.00	0,5	1,0	8°	0,1	01			▲/▲			▲/▲					
R/L312.0808.00	0,8	1,5	8°	0,1	01			▲/▲			▲/▲					
R/L312.0510.00	1,0	8,0	5°	0,1	01			▲/▲			▲/▲					
R/L312.1210.00	1,0	8,0	12°	0,1	01			▲/▲			▲/▲		Δ/Δ		▲/▲	
R/L312.0512.00	1,2	8,0	5°	0,2	01			▲/▲			▲/▲					
R/L312.0515.00	1,5	8,0	5°	0,2	01	▲/x	▲/x	▲/▲	▲/x	Δ/x	▲/▲	▲/x		▲/x		▲/x

- ▲ ab Lager / on stock Δ 4 Wochen / 4 weeks x auf Anfrage / upon request
- empfohlen / recommended
- o bedingt einsetzbar / alternative recommendation
- nicht geeignet / not suitable
- unbeschichtete HM-Sorten / uncoated grades
- beschichtete HM-Sorten / coated grades
- bestückt/Cermet / brazed/Cermet

Abmessungen in mm
Dimensions in mm
Ausführung R oder L angeben
State R or L version

P	●	●	●	●	●	●	●	●	●	●	●	●	●	●	●	●
M	o	-	●	o	-	●	o	●	●	●	o	●	●	-	●	o
K	●	-	o	o	-	●	●	●	●	●	●	●	●	-	●	-
N	●	-	-	-	-	●	-	-	-	●	●	●	●	-	●	-
S	o	-	-	-	-	●	o	●	●	o	o	●	o	-	●	-
H	-	-	-	-	-	-	-	-	-	-	-	-	-	-	-	-

HM-Sorten
Carbide grades



Abstechen

Parting Off



Wendeschneidplatte

Indexable insert

312

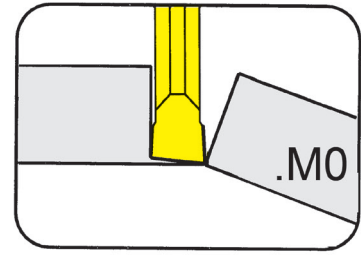

Stechtiefe bis Stechbreite	Depth of groove up to Width of groove	8 mm 1,2-1,5 mm
-------------------------------	--	--------------------

für Klemmhalter
for Toolholder

- Typ 360
Type 361
368
369
391
64/65/99
N67/N68/N98

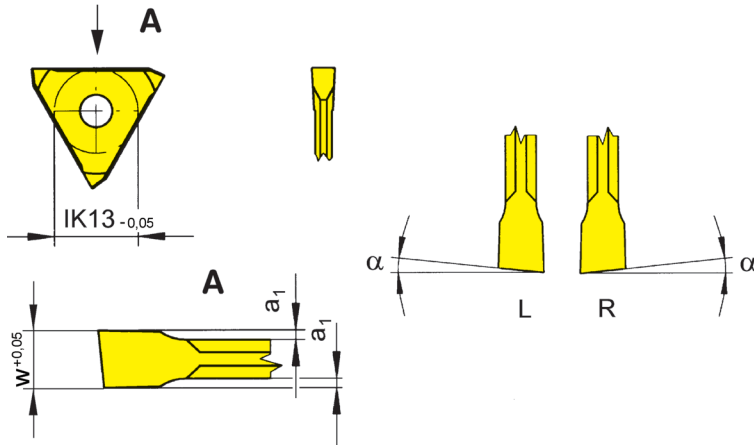

R = rechts wie gezeichnet
R = right hand version shown

L = links spiegelbildlich
L = left hand version

Bestellnummer Part number	w	t _{max}	α	a ₁	Größe Size	K10	EG35	TF45
R/L312.0512.M0	1,2	8	5°	0,2	01	Δ/Δ	▲/▲	▲/▲
R/L312.0515.M0	1,5	8	5°	0,2	01	▲/Δ	▲/▲	▲/▲

▲ ab Lager / on stock Δ 4 Wochen / 4 weeks x auf Anfrage / upon request

● empfohlen / recommended

o bedingt einsetzbar / alternative recommendation

- nicht geeignet / not suitable

□ unbeschichtete HM-Sorten / uncoated grades

■ beschichtete HM-Sorten / coated grades

■ bestückt/Cermet / brazed/Cermet

	P	M	K	N	S	H
K10	●	●	●	●	●	-
EG35	○	●	●	-	-	-
TF45	●	●	●	●	●	-

HM-Sorten
Carbide grades

Abmessungen in mm

Dimensions in mm

Ausführung R oder L angeben

State R or L version

G

Einstechen und Abstechen

Grooving and Parting Off



Wendeschneidplatte

Indexable insert

312

mit runder Spanleitstufe
with round chip breaker

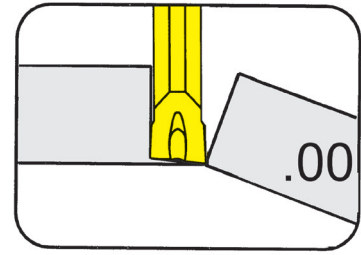

Stechtiefe bis Stechbreite	Depth of groove up to Width of groove	5 mm 1,44-2,29 mm
-------------------------------	--	----------------------

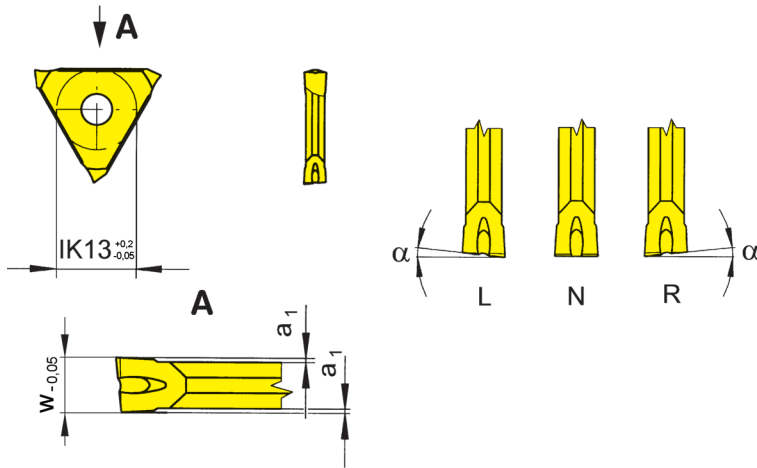

für Klemmhalter
for Toolholder

- Typ 360
Type 361
368
369
391
64/65/99
N67/N68/N98

R = rechts wie gezeichnet
R = right hand version shown

L = links spiegelbildlich
L = left hand version

Bestellnummer Part number	w	α	a_1	Größe Size	MG12	P20	EG55	TC92	TF45	TN32	TN35
R/L312.0514.00	1,44	5°	0,2	01/02		Δ/Δ	Δ/Δ		▲/Δ		
R/L312.0518.00	1,99	5°	0,2	02		▲/▲	▲/▲	Δ/Δ		▲/▲	▲/▲
R/L312.0521.00	2,29	5°	0,2	02	Δ/Δ	Δ/▲	▲/Δ	Δ/Δ		▲/▲	▲/▲
N312.0014.00	1,44	0°	0,2	01/02			▲	Δ	▲		
N312.0018.00	1,99	0°	0,2	02			▲	Δ	▲	Δ	Δ
N312.0021.00	2,29	0°	0,2	02		Δ	▲	Δ			▲

- ▲ ab Lager / on stock Δ 4 Wochen / 4 weeks x auf Anfrage / upon request
- empfohlen / recommended
- o bedingt einsetzbar / alternative recommendation
- nicht geeignet / not suitable
- unbeschichtete HM-Sorten / uncoated grades
- beschichtete HM-Sorten / coated grades
- bestückt/Cermet / brazed/Cermet

P	o	●	●	●	●	●	●	●	●	●	●
M	-	-	o	-	●	-	-	-	-	-	●
K	-	-	o	-	●	-	-	-	●	-	●
N	-	-	-	-	●	-	-	-	●	-	●
S	-	-	-	-	●	-	-	-	●	-	●
H	-	-	-	-	-	-	-	-	-	-	-

HM-Sorten
Carbide grades

Abmessungen in mm
Dimensions in mm

Ausführung R oder L angeben
State R or L version

Außenbearbeitung:

für Klemmhalter Typ 360 rechte WSP in linken, linke WSP in rechten Klemmhaltern verwenden.

External machining:

for Toolholder type 360 use right hand inserts in left hand toolholders and left hand inserts in right hand toolholders

Abstechen von Wellen
parting off solid bars

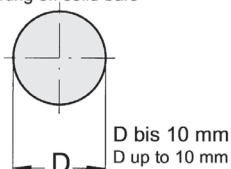

Abstechen von Rohren
parting off tubes

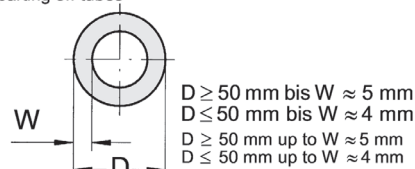

G

Abstechen

Parting Off



Wendeschneidplatte

Indexable insert

312

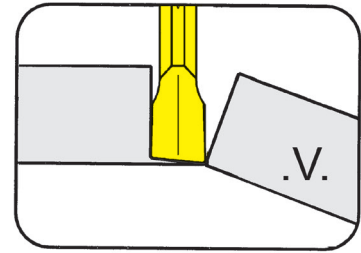

Stechtiefe bis Stechbreite	Depth of groove up to Width of groove	8 mm 1,2-2 mm
-------------------------------	--	------------------

für Klemmhalter
for Toolholder

- Typ 360
Type 361
368
369
391
64/65/99
N67/N68/N98

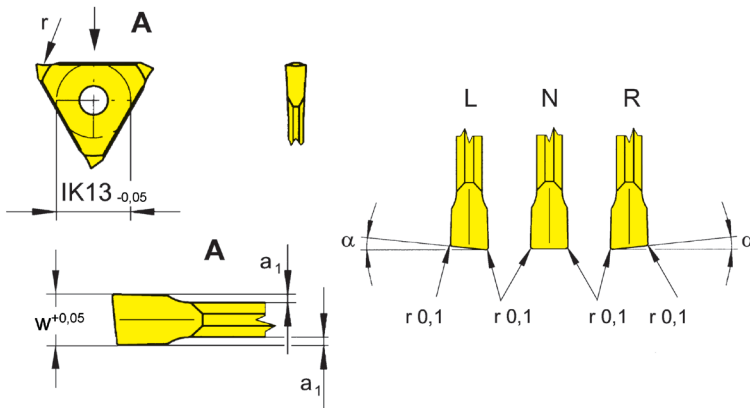

R = rechts wie gezeichnet
R = right hand version shown

L = links spiegelbildlich
L = left hand version

Bestellnummer Part number	w	α	a_1	Größe Size	EG35	TF45	TH35
312.0012.V1	1,2	0°	0,2	01	▲	▲	
R/L312.0512.V1	1,2	5°	0,2	01	▲/▲	▲/▲	
312.0015.V1	1,5	0°	0,2	01	▲	▲	
R/L312.0515.V1	1,5	5°	0,2	01	▲/▲	▲/▲	
R/L312.0520.V2	2,0	5°	0,2	01	▲/▲		▲/▲

▲ ab Lager / on stock Δ 4 Wochen / 4 weeks x auf Anfrage / upon request

● empfohlen / recommended

o bedingt einsetzbar / alternative recommendation

- nicht geeignet / not suitable

■ unbeschichtete HM-Sorten / uncoated grades

■ beschichtete HM-Sorten / coated grades

■ bestückt/Cermet / brazed/Cermet

Abmessungen in mm

Dimensions in mm

Ausführung R oder L angeben

State R or L version

WSP R/L312...V2 für Halter R/L368.2608.10.01

Indexable insert R/L312...V2 for Toolholder R/L368.2608.10.01

P	●	●	●
M	●	●	●
K	○	●	●
N	-	●	●
S	-	●	●
H	-	-	-

HM-Sorten
Carbide grades

G

32T

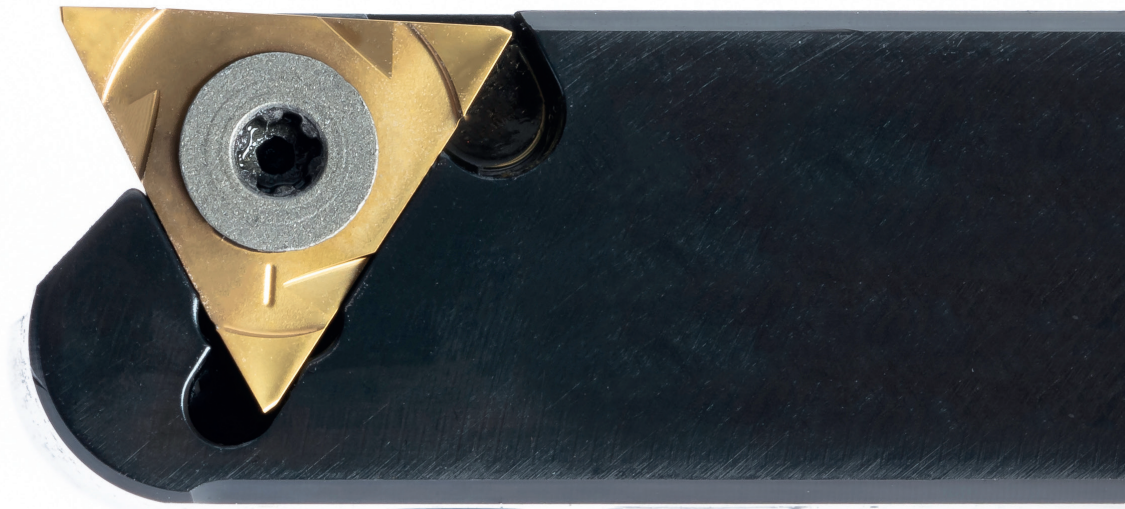

**Klemmhalter mit
Schneidplatten**

Stechbreite 0,5 - 2,5 mm

**Toolholder with
Inserts**

Width of groove 0,5 - 2,5 mm

Klemmhalter
Toolholder
H32T

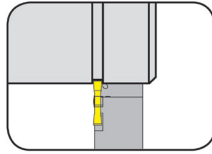

Seite/Page
H3

Wendeschneidplatte
Indexable insert
S32T

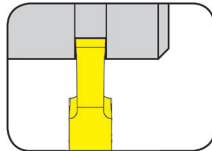

Seite/Page
H4-H5

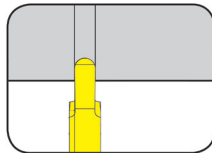

Seite/Page
H6

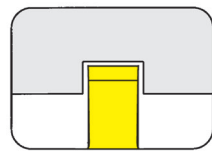

Seite/Page
H7

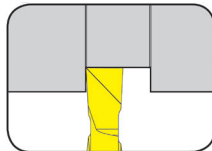

Seite/Page
H8

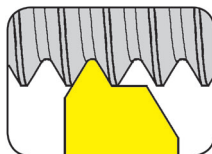

Seite/Page
H9

Einstechen und Abstechen (außen)

Grooving and Parting off (external)



Klemmhalter

Toolholder

H32T

mit innerer Kühlmittelzufuhr
with through coolant supply

Stechtiefe	Depth of groove	3,5 mm
------------	-----------------	--------

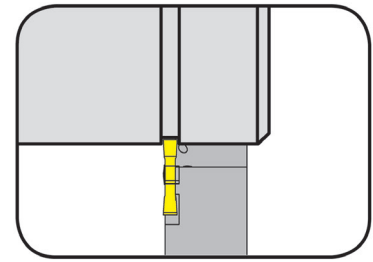

für Wendeschneidplatte
for Indexable insert

Typ S32T
Type

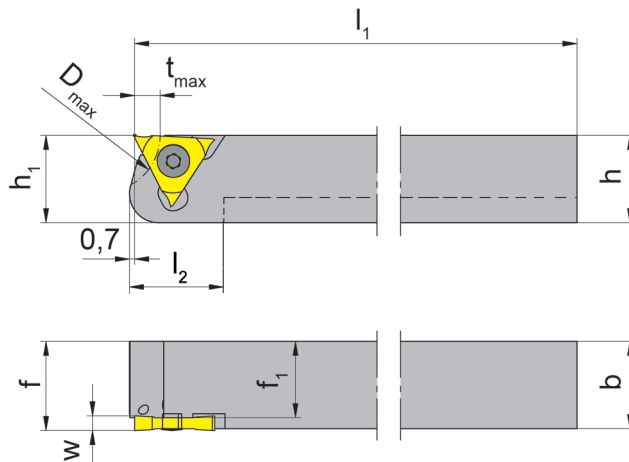

R = rechts wie gezeichnet
R = right hand version shown

L = links spiegelbildlich
L = left hand version

Bestellnummer Part number	h	b	l ₁	l ₂	h ₁	f ₁	f	D _{max}	t _{max}	Größe Size
R/LH32T.0808.6.10.IK	8	8	100	13	8	6,5	f ₁ +s ₁	15,5	3,5	01
R/LH32T.0808.6.20.IK	8	8	100	13	8	6,0	f ₁ +s ₁	15,5	3,5	02
R/LH32T.1010.6.10.IK	10	10	100	-	10	8,5	f ₁ +s ₁	15,5	3,5	01
R/LH32T.1010.6.20.IK	10	10	100	-	10	8,0	f ₁ +s ₁	15,5	3,5	02
R/LH32T.1212.6.10.IK	12	12	100	-	12	10,5	f ₁ +s ₁	15,5	3,5	01
R/LH32T.1212.6.20.IK	12	12	100	-	12	10,0	f ₁ +s ₁	15,5	3,5	02
R/LH32T.1616.6.10.IK	16	16	125	-	16	14,5	f ₁ +s ₁	15,5	3,5	01
R/LH32T.1616.6.20.IK	16	16	125	-	16	14,0	f ₁ +s ₁	15,5	3,5	02

Ausführung R oder L angeben
State R or L version

w, s₁ siehe WSP
w, s₁ see indexable inserts

Abmessungen in mm
Dimensions in mm

Das Anzugsdrehmoment der Schraube 030.2507.T7P beträgt 1,5 Nm.
Torque specification of the screw 030.2507.T7P = 1,5 Nm.

Ersatzteile

Spare Parts

Klemmhalter Toolholder	Gewindestift Threaded Pin	Spannschraube Clamping Screw	TORX PLUS®-Schlüssel TORX PLUS® Wrench	Kühlmittelanschluss Coolant supply
R/LH32T.0808.6...	3.03.913	030.2507.T7P	T7PL	004.00.37
R/LH32T.1010.6...	3.03.913	030.2507.T7P	T7PL	004.00.22
R/LH32T.1212.6...	3.03.913	030.2507.T7P	T7PL	004.00.22
R/LH32T.1616.6...	18.05.913	030.2507.T7P	T7PL	004.00.16

Einstecken und Abstecken (außen)

Grooving and Parting off (external)



Wendeschneidplatte

Indexable insert

S32T

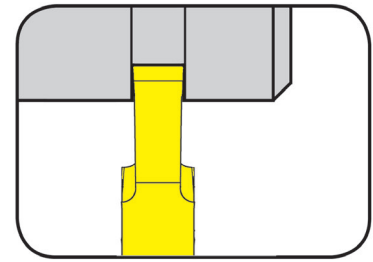

Stechtiefe bis Stechbreite	Depth of groove up to Width of groove	3,5 mm 0,5-2,5 mm
-------------------------------	--	----------------------

für Klemhalter
for Toolholder

Typ H32T
Type HU32T

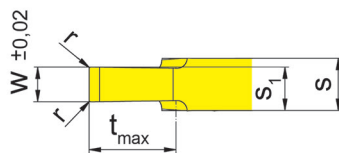
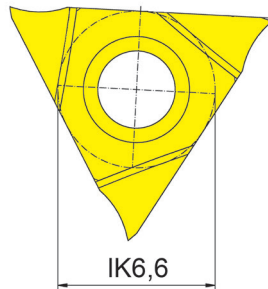

Bestellnummer Part number	w	r	s	s ₁	t _{max}	Größe Size	EG35	EG55
S32T.0050.00	0,5	0,05	1,5	1,00	1,5	01	▲	
S32T.0070.00	0,7	0,05	1,5	1,10	2,0	01	▲	
S32T.0080.00	0,8	0,05	1,5	1,15	2,5	01	▲	
S32T.0100.00	1,0	0,05	1,5	1,25	2,5	01		▲
S32T.0120.00	1,2	0,05	1,5	1,35	2,5	01		▲
S32T.0150.00	1,5	0,05	1,5	1,50	2,5	01		▲
S32T.0200.00	2,0	0,05	1,5	1,75	3,5	01		▲
S32T.0250.00	2,5	0,05	2,0	2,25	3,5	02		▲

▲ ab Lager / on stock Δ 4 Wochen / 4 weeks x auf Anfrage / upon request

● empfohlen / recommended

o bedingt einsetzbar / alternative recommendation

- nicht geeignet / not suitable

■ unbeschichtete HM-Sorten / uncoated grades

■ beschichtete HM-Sorten / coated grades

■ bestückt/Cermet / brazed/Cermet

Abmessungen in mm

Dimensions in mm

Wendeschneidplatten sind in rechten und linken Klemmaltern verwendbar.

Indexable inserts can be used in right and left hand toolholders.

P	●	●
M	●	○
K	○	○
N	-	-
S	-	-
H	-	-

HM-Sorten
Carbide grades

Einstechen und Abstechen (außen)

Grooving and Parting off (external)



Wendeschneidplatte

Indexable insert

S32T

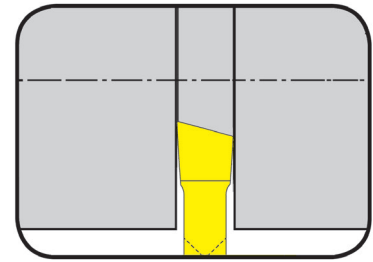

Stechtiefe bis Stechbreite	Depth of groove up to Width of groove	3,5 mm 2 mm
-------------------------------	--	----------------

für Klemmhalter
for Toolholder

Typ H32T
Type

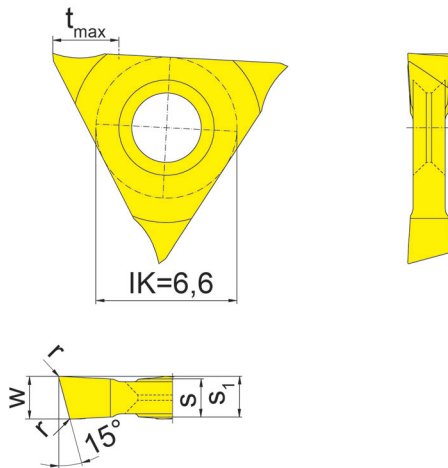

R = rechts wie gezeichnet
R = right hand version shown

L = links spiegelbildlich
L = left hand version

Bestellnummer Part number	w	r	s	s ₁	t _{max}	Größe Size	EG55
R/LS32T.1520.10	2	0,05	1,5	1,75	3,5	01	▲/▲

- ▲ ab Lager / on stock Δ 4 Wochen / 4 weeks x auf Anfrage / upon request
- empfohlen / recommended
- o bedingt einsetzbar / alternative recommendation
- nicht geeignet / not suitable
- unbeschichtete HM-Sorten / uncoated grades
- beschichtete HM-Sorten / coated grades
- bestückt/Cermet / brazed/Cermet

Abmessungen in mm
Dimensions in mm

Ausführung R oder L angeben
State R or L version

Rechte WSP in rechten, linke WSP in linken Klemmhaltern verwenden.
Use right hand inserts in right hand toolholders and left hand inserts in left hand toolholders

HM-Sorten
Carbide grades

P	●
M	○
K	○
N	-
S	-
H	-

Einstecken (außen)

Grooving (external)



Wendeschneidplatte

Indexable insert

S32T

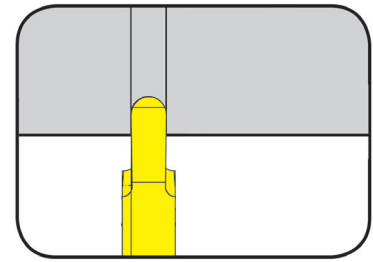

Stechbreite Vollradius	Width of groove Full radius	0,5-2 mm 0,25-1 mm
---------------------------	--------------------------------	-----------------------

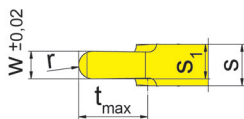
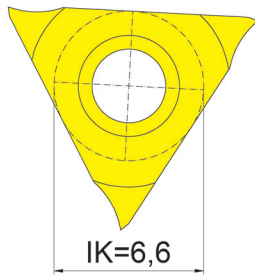

für Klemmhalter
for Toolholder

Typ H32T
Type

Bestellnummer Part number	w	s	s ₁	t _{max}	r	Größe Size	EG35	EG55
S32T.0050.25	0,5	1,5	1,00	1,5	0,25	01	▲	▲
S32T.0100.50	1,0	1,5	1,25	2,5	0,50	01		▲
S32T.0200.10	2,0	1,5	1,75	3,5	1,00	01		▲

▲ ab Lager / on stock Δ 4 Wochen / 4 weeks x auf Anfrage / upon request

● empfohlen / recommended

o bedingt einsetzbar / alternative recommendation

- nicht geeignet / not suitable

■ unbeschichtete HM-Sorten / uncoated grades

■ beschichtete HM-Sorten / coated grades

■ bestückt/Cermet / brazed/Cermet

Abmessungen in mm

Dimensions in mm

Wendeschneidplatten sind in rechten und linken Klemmhaltern verwendbar.

Indexable inserts can be used in right and left hand toolholders.

	EG35	EG55
P	●	●
M	●	○
K	○	○
N	-	-
S	-	-
H	-	-

HM-Sorten
Carbide grades

Einstechen und Abstechen

Grooving and Parting Off



Wendeschneidplatte

Indexable insert

S32T

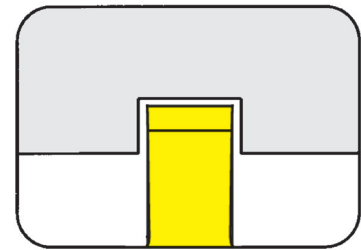

Seegerringnuten
Nutnennbreite Nw

Circlip grooves
Width of circlip Nw

DIN471/472
0,34-2,15 mm

für Klemmhalter
for Toolholder

Typ H32T
Type

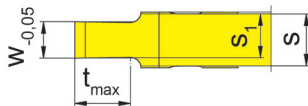
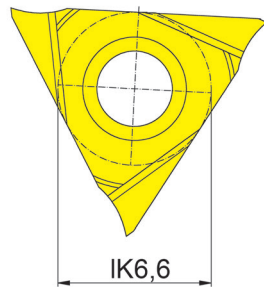

Bestellnummer Part number	w	Nw	s	s ₁	t _{max}	Größe Size	EG35	EG55
S32T.0034.01.00	0,41	0,34	1,5	0,94	0,6	01	Δ	
S32T.0044.01.00	0,51	0,44	1,5	0,99	0,7	01	Δ	
S32T.0050.01.00	0,57	0,50	1,5	1,02	0,7	01	▲	
S32T.0060.01.00	0,67	0,60	1,5	1,07	0,8	01	▲	
S32T.0070.01.00	0,77	0,70	1,5	1,12	1,1	01	▲	
S32T.0080.01.00	0,87	0,80	1,5	1,17	1,2	01	▲	
S32T.0090.01.00	0,97	0,90	1,5	1,22	1,4	01	▲	
S32T.0100.01.00	1,07	1,00	1,5	1,27	1,6	01		▲
S32T.0110.01.00	1,24	1,10	1,5	1,36	1,6	01		▲
S32T.0130.01.00	1,44	1,30	1,5	1,46	2,0	01		▲
S32T.0160.01.00	1,74	1,60	1,5	1,61	3,0	01		▲
S32T.0185.01.00	1,99	1,85	1,5	1,73	3,0	01		▲
S32T.0215.01.00	2,29	2,15	2,0	2,13	3,0	02		▲

▲ ab Lager / on stock Δ 4 Wochen / 4 weeks x auf Anfrage / upon request

● empfohlen / recommended

o bedingt einsetzbar / alternative recommendation

- nicht geeignet / not suitable

■ unbeschichtete HM-Sorten / uncoated grades

■ beschichtete HM-Sorten / coated grades

■ bestückt/Cermet / brazed/Cermet

Abmessungen in mm

Dimensions in mm

Wendeschneidplatten sind in rechten und linken Klemmhaltern verwendbar.

Indexable inserts can be used in right and left hand toolholders.

P	●	●
M	●	○
K	○	○
N	-	-
S	-	-
H	-	-

HM-Sorten
Carbide grades

H

Einstecken und Längsdrehen

Grooving and Side Turning



Wendeschneidplatte

Indexable insert

S32T

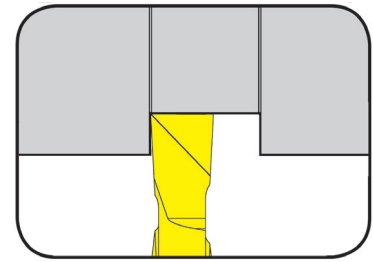

Stechtiefe bis Stechbreite	Depth of groove up to Width of groove	2 mm 1,5-2,5 mm
-------------------------------	--	--------------------

für Klemhalter
for Toolholder

Typ H32T
Type

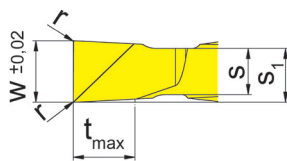
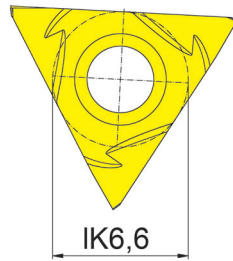

R = rechts wie gezeichnet
R = right hand version shown

L = links spiegelbildlich
L = left hand version

Bestellnummer Part number	w	r	s	s ₁	t _{max}	Größe Size	EG55
R/LS32T.0150.P0	1,5	0,05	1,5	1,70	2	01	▲▲
R/LS32T.0200.P0	2,0	0,05	1,5	1,75	2	01	▲▲
R/LS32T.0250.P0	2,5	0,10	2,0	2,25	2	02	▲▲

▲ ab Lager / on stock Δ 4 Wochen / 4 weeks x auf Anfrage / upon request

● empfohlen / recommended

o bedingt einsetzbar / alternative recommendation

- nicht geeignet / not suitable

■ unbeschichtete HM-Sorten / uncoated grades

■ beschichtete HM-Sorten / coated grades

■ bestückt/Cermet / brazed/Cermet

Abmessungen in mm

Dimensions in mm

Ausführung R oder L angeben

State R or L version

P	●
M	○
K	○
N	-
S	-
H	-

HM-Sorten
Carbide grades

Gewindedrehen (außen) Vollprofil

Threading (external) Full profile



Wendeschneidplatte

Indexable insert

S32T

Metrisches ISO-Gewinde
Metric ISO thread

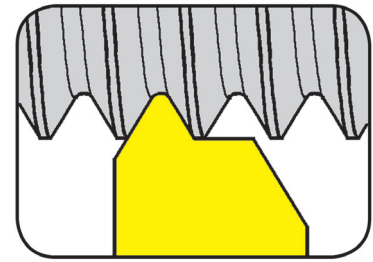

Steigung	Pitch	0,5-1,5 mm
----------	-------	------------

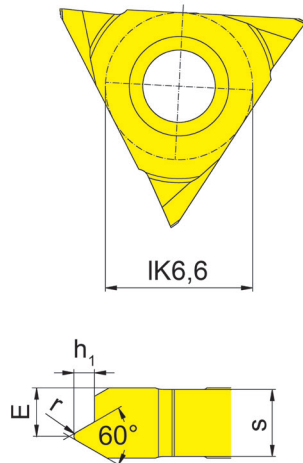

für Klemhalter
for Toolholder

Typ H32T
Type

R = rechts wie gezeichnet
R = right hand version shown

L = links spiegelbildlich
L = left hand version

Bestellnummer Part number	P	E	r	h ₁	s	Größe Size	EG55
R/LS32T.0305.02	0,50	1,6	0,07	0,32	2	02	▲▲
R/LS32T.0306.02	0,60	1,5	0,09	0,38	2	02	▲▲
R/LS32T.0307.02	0,70	1,5	0,10	0,44	2	02	▲▲
R/LS32T.0407.02	0,75	1,5	0,11	0,47	2	02	▲▲
R/LS32T.0408.02	0,80	1,4	0,12	0,50	2	02	▲▲
R/LS32T.0610.02	1,00	1,4	0,14	0,62	2	02	▲▲
R/LS32T.0712.02	1,25	1,4	0,18	0,78	2	02	▲▲
R/LS32T.0915.02	1,50	1,3	0,22	0,93	2	02	▲▲

▲ ab Lager / on stock Δ 4 Wochen / 4 weeks x auf Anfrage / upon request

● empfohlen / recommended

o bedingt einsetzbar / alternative recommendation

- nicht geeignet / not suitable

■ unbeschichtete HM-Sorten / uncoated grades

■ beschichtete HM-Sorten / coated grades

■ bestückt/Cermet / brazed/Cermet

Abmessungen in mm

Dimensions in mm

Ausführung R oder L angeben

State R or L version

P	●
M	○
K	○
N	-
S	-
H	-

HM-Sorten
Carbide grades

H



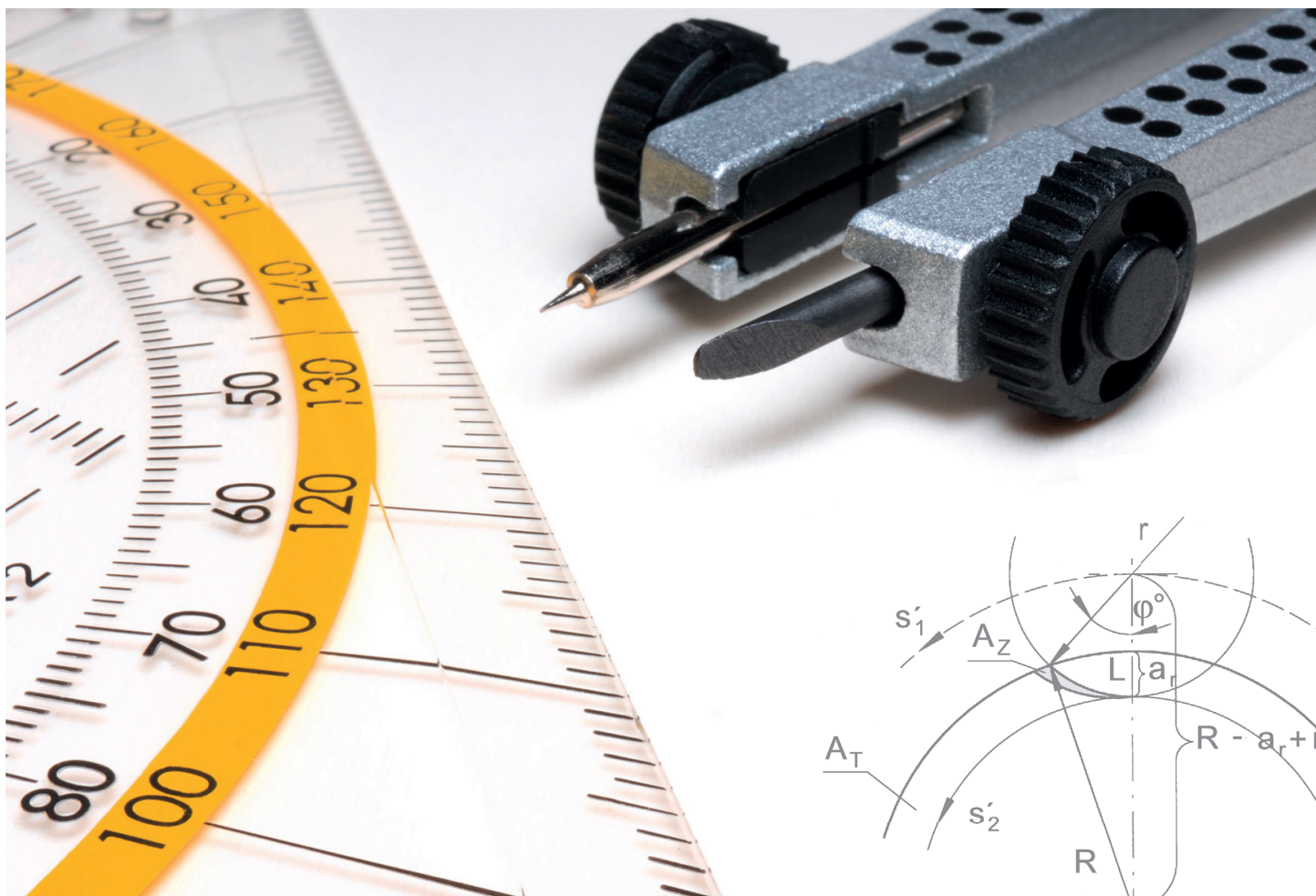

Inhalt/Summary	Seite/Page
Beschreibung HM-Sorten	I2-I3
Description Carbide Grades	
Beschichtungsleitfaden	I4-I5
Coating Guide Line	
Anzugsmomente	I6-I7
Torque Specification	
Technische Informationen	I8-I13
Technical Information	
Geometrien und Vorschübe	I14-I20
Geometries and feed rates	
Schnittdaten	I21-I23
Cutting Data	

HORN-Sorten	ISO513	Eigenschaften	Hauptanwendung	Anwendungsgebiete
H20 H54	HT	Cermet	unlegierte C-Stähle, niedrig legierte Stähle, Stahlguss, rostfreie Stähle, exotische Legierungen	zum Vor- und Fertigstechen mit hervorragender Oberflächengüte, neigt nicht zur Aufbauschnneidenbildung, verschleißfest
K10	HW	unbeschichtetes Hartmetall	Aluminium- und Kupferlegierungen	zum Vor- und Fertigstechen
MG12	HF	unbeschichtetes Hartmetall (Feinkorn)	Aluminium- und Kupferlegierungen	zum Vor- und Fertigstechen bei niedriger Schnittgeschwindigkeit, ungünstige Bedingungen
AS62	HC	AlTiN-Beschichtung	alle Arten von Stahl und Stahlguss	zum Vor- und Fertigstechen bei mittlerer Schnittgeschwindigkeit
TH36 AS46 AS66	HC	AlTiN-Beschichtung	alle Arten von Stahl und Stahlguss	zum Vor- und Fertigstechen bei sehr hoher Schnittgeschwindigkeit, warmfest, geeignet für Trockenbearbeitung
EG35 EG55	HC	AlTiN- Beschichtung mit TiN-Verschleißerkennung	alle Arten von Stahl und Stahlguss, ausgenommen nichtrostender Stahl mit austenitischem Gefüge	zum Vor- und Fertigstechen bei hoher Schnittgeschwindigkeit
ES15	HC	AlTiN-Beschichtung	alle Arten von Stahl und Stahlguss	zum Fertigstechen und Feinstbearbeitungen sowie μ -Finish-Anwendungen
TH35 AS6G	HC	AlTiN-Beschichtung	alle Arten von Stahl und Stahlguss	zum Vor- und Fertigstechen bei hoher Schnittgeschwindigkeit
HP65 HP66	HC	AlTiN-Beschichtung	alle Arten von Stahl und Stahlguss martensitischer rostfreier Stahl	zum Vor- und Fertigstechen bei mittlerer Schnittgeschwindigkeit, warmfest
IG35 IG36	HC	AlTiSiN-Beschichtung	nichtrostender, austenitischer Stahl und austenitisch-ferritischer Stahl und Stahlguss sowie Superlegierungen und Titan	zum Vor- und Fertigstechen bei hoher Schnittgeschwindigkeit, warmfest, geeignet für Trockenbearbeitung
DD25 DD26	HC	Titandiborid-Beschichtung	legierte Nichteisen-Metalle wie Aluminiumlegierungen oder bleifreies Messing	zum Vor- und Fertigstechen bei sehr hoher Schnittgeschwindigkeit, warmfest
HS35 HS36	HC	AlTiSiN-Beschichtung	Warmfeste, schwer zerspanbare Superlegierungen mit hohen Bestandteilen aus Eisen, Nickel, Kobalt und/oder Titan	zum Vor- und Fertigstechen bei hoher Schnittgeschwindigkeit, warmfest, geeignet für Trockenbearbeitung

PKD- oder CBN-bestückte Schneidplatten auf Anfrage lieferbar..

Lagerhaltige HM-Sorten sind im Katalog bzw. in der Preis- und Lagerliste aufgeführt. Nicht aufgeführte HM-Sorten können auf Bestellung gefertigt werden.

Description carbide grades



HORN-Grades	ISO513	Properties	Main applications	Recommended applications
H20	HT	Cermet	carbon steels, low alloyed steels, cast steel, stainless steel, exotic alloys	for grooving and finishing, for high quality surface finish, no tendency to built up edge, resistant to wear
K10	HW	uncoated grades	Aluminium and copper alloys	for grooving and finishing
MG12	HF	uncoated grades (micro grain)	Aluminium and copper alloys	for grooving and finishing, at low cutting speed, unfavourable conditions
AS62	HC	AlTiN coating	all types of steel and cast steel	for grooving and finishing at medium cutting speed
TH36 AS46 AS66	HC	AlTiN coating	all types of steel and cast steel	for grooving and finishing, at very high cutting speed, heat resistant, suitable for dry cutting
EG35 EG55	HC	AlTiN coating with TiN wear detection	all types of steel and cast steel, excluding stainless steel with austenitic structure	for grooving and finishing at high cutting speed
ES15	HC	AlTiN coating	all types of steel and cast steel	for finishing, ultrafine machining and μ -finish applications
TH35 AS6G	HC	AlTiN coating	all types of steel and cast steel	for grooving and finishing at high cutting speed
HP65 HP66	HC	AlTiN coating	all types of steel and cast steel martensitic stainless steel	for grooving and finishing at medium cutting speed, heat resistant
IG35 IG36	HC	AlTiSiN coating	stainless, austenitic steel and austenitic-ferritic steel and cast steel as well as superalloys and titanium	for grooving and finishing, at high cutting speed, heat resistant, suitable for dry cutting
DD25 DD26	HC	Titanium diboride coating	alloyed non-ferrous metals such as aluminium alloys or unleaded brass	for grooving and finishing at very high cutting speed, heat resistant
HS35 HS36	HC	AlTiSiN coating	heat resistant, difficult to machine superalloys with high contents of iron, nickel, cobalt and/or titanium	for grooving and finishing, at high cutting speed, heat resistant, suitable for dry cutting

PCD- or PCBN-tipped inserts upon request..

Carbide grades in stock are shown in the catalogue or in the price and stock list. Grades not listed can be supplied only to order.

Produkt	Werkstoffgruppe						HM-Sortenwahl
	P	M	K	N1	N2	S	
Supermini®	EG35 (ES35*)	IG35* (ES35*)	ES35* (EG35)	MG12 (NE25*)	DD25* (NE25*)	HS3_* (ES3_*)	<p>Beim Stechen und Supermini ISO-S ist die Hartmetallwahl stark vom zu zerspanenden Werkstoff und der Werkzeuggeometrie abhängig. Daher kann nur die Beschichtung allgemein empfohlen werden.</p> <p>Beim Stechen und Supermini ISO-S ist die Hartmetallwahl stark vom zu zerspanenden Werkstoff und der Werkzeuggeometrie abhängig. Daher kann nur die Beschichtung allgemein empfohlen werden.</p> <p>Mit * markierte Sorten können nicht mit Prio3 (GreenLine) gefertigt werden.</p>
Mini	EG55 (ES35*)	IG35* (ES35*)	ES35* (EG55)	MG12 (NE25*)	DD25* (NE25*)	HS35* (IG35*)	
	EG35 (ES15*)	ES15* (EG35)	ES35* (EG35)	MG12 (NE25*)	DD25* (NE25*)	ES35* (IG35*)	
µ-Finish-Werkzeuge	ES15* (AC25*)		-	-	-	-	
Nuststoßen	EG35 (AN25*)	IG35* (ES35*)	ES35* (EG35)	MG12 (NE25*)	DD25* (NE25*)	HS35* (IG35*)	
	EG5_* (ES3_*)	IG3_* (HP6_*)	ES3_* (EG5_)	MG12 (NE2_*)	DD2_* (NE2_*)	HS3_* (IG3_*)	
Stechen (Schneidbreite ≤ 3,0 mm)	EG5_* (ES6_*)		ES6_* (EG5_)				
	AN4_* (ES3_*)	-	ES3_* (AN4_*)	-	-	-	
Trocken / MMS	EG55 (ES65*)	IG35* (ES35*)	ES65* (EG55)	MG12 (NE25*)	DD25* (NE25*)	IG35* (HS35*)	
P	alle Arten von Stahl und Stahlguss, ausgenommen nichtrostender Stahl mit austenitischem Gefüge (z.B. C45 / 1.0503, 100Cr6 / 1.3505)						
M	nichtrostender, austenitischer Stahl und austenitisch-fertischer Stahl und Stahlguss (z. B. X2CrNiMoCuWN25-7-4 / 1.4501, X6CrNiMoTi17-12-2 / 1.4571)						
K	Gusseisen mit Lamellen- und Kugelgraphit, Temperguss (z. B. EN-GJS-400-15 / GGG-40)						
N1	bleinartiges Messing und unlegierte Nichtisen-Metalle (z.B. reines Aluminium / reines Kupfer)						
N2	unlegiertes Titan und legierte Nichtisen-Metalle (z.B. Aluminiumlegierungen / bleifreies Messing)						
S	Warmfeste, schwer zerspanbare Superlegierungen mit hohen Bestandteilen aus Eisen, Nickel, Kobalt und/oder Titan (z.B. Inconel 718 / 2.4668, A286 / 1.4980, Stellite)						

Product	Material group						Choice of carbide grade
	P	M	K	N1	N2	S	
Supermini®	EG35 (ES35*)	IG35* (ES35*)	ES35* (EG35)	MG12 (NE25*)	DD25* (NE25*)	HS3_* (ES3_*)	<p>In the case of grooving and Supermini ISO-S, the choice of carbide is heavily dependent on the material being machined and on the tool geometry. Therefore, only a general recommendation can be given for the coating.</p> <p>Grades marked with * cannot be produced with priority 3 (GreenLine).</p>
Mini	EG55 (ES35*)	IG35* (ES35*)	ES35* (EG55)	MG12 (NE25*)	DD25* (NE25*)	HS35* (IG35*)	
Sharp abrasive tools	EG35 (ES15*)	ES15* (EG35)	ES35* (EG35)	MG12 (NE25*)	DD25* (NE25*)	ES35* (IG35*)	
µ-finish tools	ES15* (AC25*)		-	-	-	-	
Broaching	EG35 (AN25*)	IG35* (ES35*)	ES35* (EG35)	MG12 (NE25*)	DD25* (NE25*)	HS35* (IG35*)	
Grooving (cutting width ≤ 3.0 mm)	EG5_* (ES3_*)	IG3_* (HP6_*)	ES3_* (EG5_)	MG12 (NE2_*)	DD2_* (NE2_*)	HS3_* (IG3_*)	
Grooving (cutting width ≥ 3.0 mm)	EG5_* (ES6_*)		ES6_* (EG5_)				
Dry / MQL	AN4_* (ES3_*)	-	ES3_* (AN4_*)	-	-	-	
Milling	EG55 (ES65*)	IG35* (ES35*)	ES65* (EG55)	MG12 (NE25*)	DD25* (NE25*)	IG35* (HS35*)	
P	All types of steel and cast steel, excluding stainless steel with an austenitic structure (e.g. C45 / 1.0503, 100Cr6 / 1.3505)						
M	Stainless austenitic and duplex steel, plus cast steel (e.g. X2CrNiMoCuWN25-7-4 / 1.4501, X6CrNiMoTi17-12-2 / 1.4571)						
K	Grey and ductile cast iron, malleable cast iron (z.B. EN-GJS-400-15 / GGG-40)						
N1	leaded brass and unalloyed non-ferrous metals (e.g., pure aluminium / pure copper)						
N2	unalloyed titanium and alloyed non-ferrous metals (e.g., aluminium alloys / unleaded brass)						
S	Heat resistant, difficult to machine superalloys with high content of iron, nickel, cobalt and / or titanium (e.g. Inconel 718 / 2.4668, A286 / 1.4980, Stellite)						

Anzugsmomente

Torque of Screws



Nachstehende Drehmomente sind für die Spannschrauben zulässig. Wir empfehlen keine zusätzlichen Gleitmittel wie Kupferpaste oder ähnliches für die Schrauben zu verwenden. Die passenden Drehmomentschlüssel finden Sie im Kapitel Zubehör.

Following torques are allowed for screws of MINI inserts. We recommend to use no additional gliding means (such as copper paste) for screws. For torque screw drivers please see chapter additional equipment.

Typ Kapitel A Type Chapter A	Schraube Screw	M _d Nm	Schlüssel Clamping wrench	Klinge Blade
B105	6.075T15P	5,0	T15PQ	DT15PK
B105.00...S...03/04/05	030.0000.0991	2,0	T15PL	DT15PK
BGT001.C...	DIN912M5x14	5,0	SW4DIN911	DSW40K
BU105	6.075T15P	5,0	T15PQ	DT15PK
H105	6.075T15P	5,0	T15PQ	DT15PK
HC105	6.075T15P	5,0	T15PQ	DT15PK
IR105	6.075T15P	5,0	T15PQ	DT15PK
N...	6.075T15P	5,0	T15PQ	DT15PK
962	6.075T15P	5,0	T15PQ	DT15PK
963	6.075T15P	5,0	T15PQ	DT15PK

Typ Kapitel B Type Chapter B	Schraube Screw	M _d Nm	Schlüssel Clamping wrench	Klinge Blade
H100...01/...11/...21 + IK H100...02/...12/...22 + IK	4.15T15P	5,0	T15PQ	DT15PK
H100...03/...13/...23 H100...22.IK	5.17T20P	6,5	T20PQ	DT20PK/DT20PQ
H100...23.IK	6.23T25P	7,0	T25PQ	DT25PK/DT25PQ

Typ Kapitel C Type Chapter C	Schraube Screw	M _d Nm	Schlüssel Clamping wrench	Klinge Blade
H101	3.5.12T10EP	3,0	T10PL	DT10PK

Typ Kapitel D Type Chapter D	Schraube Screw	M _d Nm	Schlüssel Clamping wrench	Klinge Blade
H262	030.2557.T8P	1,0	T8PL	DT8PK

Typ Kapitel E Type Chapter E	Schraube Screw	M _d Nm	Schlüssel Clamping wrench	Klinge Blade
H264	3.5.12T10EP	3,0	T10PL	DT10PK

Nachstehende Drehmomente sind für die Spannschrauben zulässig. Wir empfehlen keine zusätzlichen Gleitmittel wie Kupferpaste oder ähnliches für die Schrauben zu verwenden. Die passenden Drehmomentschlüssel finden Sie im Kapitel Zubehör.

Following torques are allowed for screws of MINI inserts. We recommend to use no additional gliding means (such as copper paste) for screws. For torque screw drivers please see chapter additional equipment.

Typ Kapitel F Type Chapter F	Schraube Screw	M _d Nm	Schlüssel Clamping wrench	Klinge Blade
H274...04/...04.E	030.3509.T15P	3,0	T15PQ	DT15PK
H274...07	030.3513.T15P	3,0	T15PQ	DT15PK
KT274 KTC274	030.3509.T15P	3,0	T15PQ	DT15PK
974	030.3509.T15P	3,0	T15PQ	DT15PK
H274...SF	030.350P.0852	3,0	T15PQ	DT15PK

Typ Kapitel G Type Chapter G	Schraube Screw	M _d Nm	Schlüssel Clamping wrench	Klinge Blade
360	6.25	4,5	SW3DIN911	DSW30K
361	030.0422.T10P	3,0	T10PL	DT10PK
368	4.15T15P	4,0	T15PQ	DT15PK
391.1212...	030.0422.T10P	3,0	T10PL	DT10PK
391.1616...	5.32.3T15P	5,0	T15PQ	DT15PK
391.2...	6.25	4,5	SW3DIN911	DSW30K

Typ Kapitel H Type Chapter H	Schraube Screw	M _d Nm	Schlüssel Clamping wrench	Klinge Blade
H32T...	030.2507.T7P	1,5	T7PL	DT7PK

Längsdrehen Side Turning

HORN-Einsteckwerkzeuge gewährleisten auch bei Formeinstichen mit einseitigen Schnittkräften absolute Form- und Winkelgenauigkeit.

Ein Auslenken der Schneide ist drehtechnisch wünschenswert, beim Einstechen jedoch nicht vertretbar.

HORN-Grooving Tools will give you absolute accuracy of profile and angles, even when profiling with one-sided cutting forces.

A flexible cutting edge would be desirable for turning, but not useful for precision grooving.

Bitte beim Einrichten des Werkzeuges beachten:

Richten Sie das Werkzeug (Schneide) stets rechtwinklig zur Werkstückachse aus.

Please note when setting tool:

Always ensure that the tool is perpendicular to the axis of the workpiece.

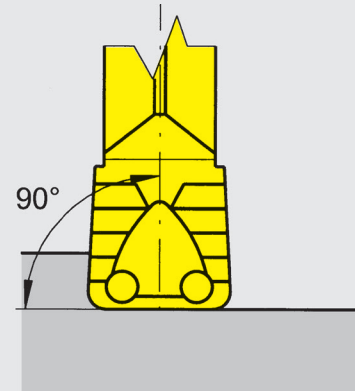

Unsachgemäße Ausrichtung:

Bei Vorschubrichtung **1** treten Vibrationen auf. Stabile oder stabil gespannte Werkstücke erhöhen die Vibrationsneigung.

Vorschubrichtung **2** ist für das DREHEN ideal und hat auf die Funktionen keine negativen Auswirkungen.

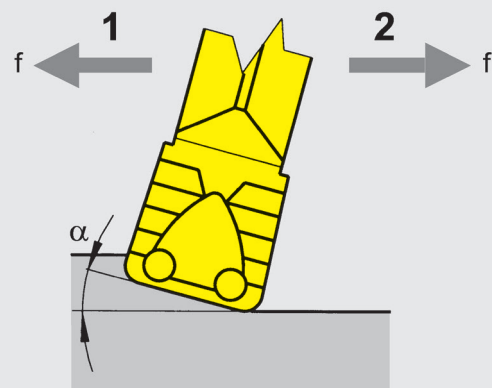

Improper setting:

Feed direction **1** will create vibrations. The tendency to vibrate will increase on rigid workpieces.

Feed direction **2** is suitable for turning and will have no negative effects to the operation.

Längsdrehen Side Turning

Einstechwerkzeuge sind kein Ersatz für Drehwerkzeuge mit DIN-Wendepplatten. Bei bestimmten Arbeitsgängen, z.B. beim Auskesseln, können Werkzeugwechselzeiten und damit die Hauptzeit durch Einstechwerkzeuge drastisch gesenkt werden.

The grooving tool should not be seen as a replacement for a turning tool with ISO-inserts. On certain operations, for instance grooving and turning can reduce the number of tool changes and offer reduced cycle time.

Schneidbreite:

Die Breiten 4, 5 und 6 mm sind bevorzugt für das Längsdrehen zu verwenden. Die Kontur und Stabilität des Werkstücks entscheidet über die Schneidbreite. Der größtmögliche Eckenradius ist zu wählen.

Width of insert:

The width 4, 5 and 6 mm are recommended for side turning. The profile and rigidity of the workpiece determines the width of insert. Always choose the largest possible edge radius.

Breite Width	4 mm	5 mm	6 mm	
$a_{p \max}$ f	2.8 0.15 - 0.30	3.5 0.15 - 0.40	4.0 0.15 - 0.40	.3.
$a_{p \max}$ f	2.8 0.15 - 0.30	3.5 0.15 - 0.50	4.0 0.15 - 0.60	.5.
$a_{p \max}$ f	2.8 0.10 - 0.25	3.5 0.10 - 0.30	4.0 0.10 - 0.30	.A.

Schnitttiefe a_p :

Die Schnitttiefe richtet sich nach der Breite der Schneidplatte, dem zu zerspanenden Werkstoff und der Steifigkeit des Werkstücks und wird begrenzt durch die Schneidkantenlänge.

Als Faustformel gilt: $a_{p \max} = w \times 0,7$ oder max. 3,0 mm
 $a_{p \min} = \text{Eckenradius (r)}$

Die kleinste Schnitttiefe $a_{p \min}$ entspricht dem Eckenradius der Schneidplatte. Bei geringerer Schnitttiefe entstehen ungünstige feine Bandspäne.

Maximaler Vorschub f_{\max} :

Als Faustformel gilt: $f_{\max} = w \times 0,1$

Cutting depth a_p :

When side turning the cutting depth is dependent upon the width of insert as well as on the material and the rigidity of the workpiece. The max. depth would be limited by the length of the cutting edge.

Rule of thumb for calculation: $a_{p \max} = w \times 0,7$ or max. 3,0 mm
 $a_{p \min} = \text{corner radius (r)}$

The smallest cutting depth $a_{p \min}$ is governed by the edge radius of the insert. Cutting depth below the corner radius will create poor cutting conditions.

Max. feed rate f_{\max} :

Rule of thumb for calculation: $f_{\max} = w \times 0,1$

Längsdrehen

Side Turning

Bearbeiten zwischen Schultern

Side turning between shoulders

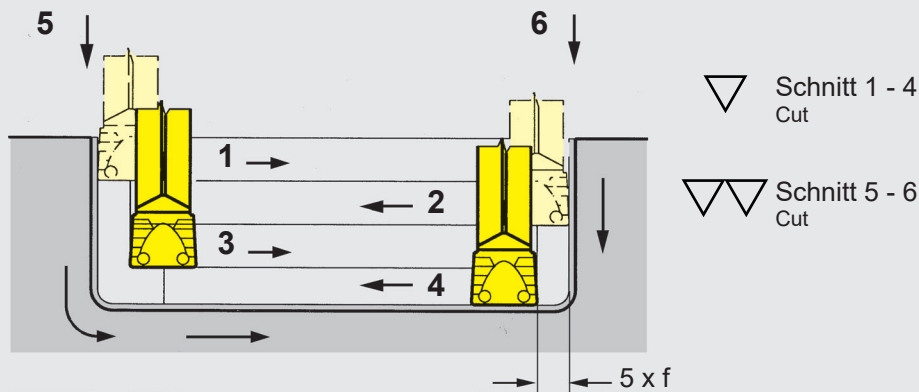

Beim Längsdrehen im Bereich einer Schulter ist stets an der Schulter zu beginnen. Wird zur Schulter hin gedreht, kann diese den Spanablauf ungünstig beeinflussen und es besteht die Gefahr des Plattenbruchs.

Beim Auskammern empfiehlt sich, wie vorstehend gezeigt vorzugehen. Schnitt 2 und weitere erfordern einen Abstand von $5 \times f$. So wird vermieden, dass der Span unter die Platte gelenkt wird.

Always start at the shoulder when side turning, towards shoulder. An operation towards the shoulder will influence the run off the chip and creates the risk of insert breaking. Grooving and turning is recommended as shown.

Cut 2 and subsequent cuts leave a distance of $5 \times f$ to the shoulder. This cut width will help to prevent swarf being trapped under the advancing cutting edge.

Fasen von Nuten mit Standard-Schneidplatten

Chamfering with standard inserts

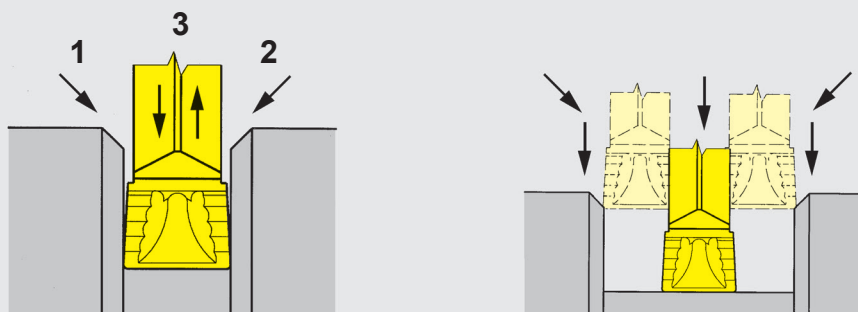

Nut entspricht Schneidbreite
Width of groove and insert are equal

Nut breiter als Schneidplatte
Groove wider than insert

Feinbearbeitung von Nuten

(Dichtnuten)

Finishing of Grooves

(Sealing Grooves)

Bedingt durch den Arbeitsablauf ergeben sich beim Schlichten von Nuten unterschiedliche Drehbilder (Stechen/Drehen). Dieser oft nur optische Unterschied ist nicht erwünscht.

Eine Lösung zeigt Abbildung 2 mit der modifizierten Schneidplatte S224...NC...D2.

This process requires both turning and grooving where very high quality surface finishes are required.

Diagram 2 shows the modified insert type S224...NC...D2.

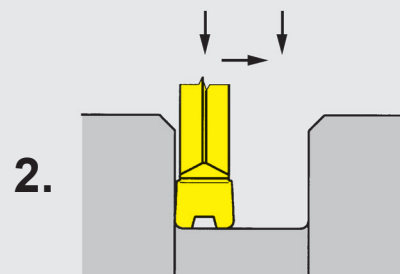
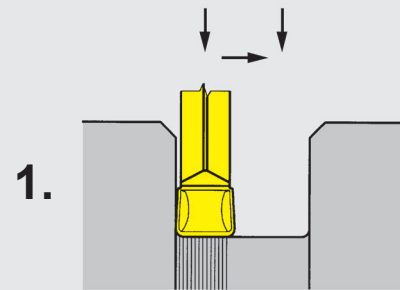

RINGBILDUNG

SWARF RING CREATION

Ringbildung wird vermieden, wenn keine überlappenden Drehoptionen vorkommen. Die Arbeitsabläufe sind so zu wählen, dass sich der Drehvorgang im überlappenden Bereich durch einen Stechvorgang abschließen lässt.

Je schärfer die Schneidplatte und je kleiner der Schneidenradius ist, desto geringer ist die Neigung zur Ringbildung.

Swarf ring creation can be avoided by turning across the smaller diameter in one continuous pass. Well defined cutting edges and small corner radii will reduce the tendency to create rings.

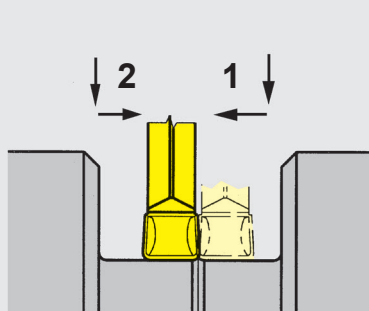

Ringbildung
 Ring creation

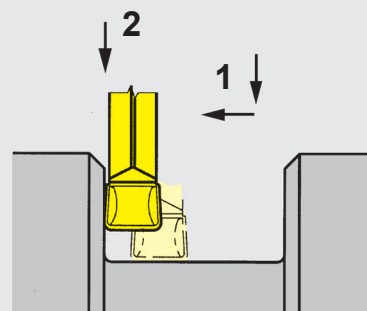

keine Ringbildung
 No ring creation

Abstechen

Parting Off

Wendeschneidplatten mit gerader Schneide

Wendeschneidplatten mit gerader Schneide sind, sofern möglich, auch beim Abstechen zu bevorzugen.

- Vorteile:
- höchste Standmengen
 - bester Spanfluss und damit gute Oberflächen
 - hohe Schnittwerte möglich

Indexable inserts with square cutting edge

The best selection for applications are inserts with a square cutting edge, wherever possible to use them.

- Advantages:
- increased tool life
 - better swarf control and a high surface quality will be obtained
 - possibility to choose the maximum cutting data

Vorschubgröße

Bei Verwendung von Abstechtschrägen kann sich der empfohlene Vorschub, der sich stets auf eine gerade Schneide bezieht, je nach Größe der Schräge bis auf 40 % reduzieren. Starker Einfluss hat hierbei die Dehnung des zu bearbeitenden Werkstoffes.

Feed rates

The feed rate when cutting with front cutting angle will need to be reduced up to 40 %. This may also be influenced by the tensile strength of the material to be cut.

Spänestau

Durch die Wahl der geeigneten Schnittgeschwindigkeit und des richtigen Vorschubs, werden Spänestau und durch Späne verletzte Oberflächen vermieden.

Swarf control

Best swarf control and highest surface finish will be obtained by choosing the right speed and feed rate.

Butzen- oder Gratbildung

Verringerung des Butzens oder des Grats wird durch exakte Einstellung auf Spitzenhöhe und durch Verwendung von R/L Schneidplatten (mit Abstechtschräge) erreicht. Gleichzeitig gewährleistet die korrekte Einstellung beste Spanformung und Spankontrolle.

Avoiding Pips

By using right or left handed inserts and the correct centre height occurring of pips and burrs can be reduced.

Abgreifen

Abgreifspindeln oder -vorrichtungen verhindern eine Beschädigung der Schneide durch Abfallen schlagender Teile.

Beim »fliegenden« Abstechen empfiehlt es sich, den Vorschub vor dem Abstechen oder Durchtrennen deutlich zu reduzieren.

Parting off with a sub spindle or part catcher

The cutting edge will be protected by having a second spindle or fixture to pick up the workpiece. Parting off without a support requires the feed rate to be reduced as the tool approaches centre.

Balligkeit der Oberfläche

Ballige Abstiche bei Verwendung von Schneidplatten mit Abstechtschräge werden durch Verringerung des Vorschubs vermindert.

Convex or concave surfaces

Convex or concave surfaces will be avoided when using right or left hand inserts by reducing the feed rate.

Kühlschmiermittel

Kühlschmiermittel ist in ausreichender Menge und platziert zuzuführen.

Coolant

A copious well aimed coolant supply will give long tool life.

Empfohlene Anzahl der Schnitte

Recommended number of passes

HM-Sorte / Carbide grade	Stahl (N/mm ² Festigkeit) Steel (N/mm ² Tensile strength)					rostfr. Stahl Stainless steel	Grauguss Grey cast iron	Aluminium Aluminium	
	400-500	500-700	700-850	850-1150	> 1150				
TN35	400-500	500-700	700-850	850-1150	> 1150	90	100	300	
V _{max} m/min	160	140	120	90	70	90	100	300	
Steigung / Pitch		Anzahl der Schnitte / Number of passes							
mm	Gg/" tpi								
0,8	32	8	8	9	9	10	10	9	8
1,0	24	10	10	12	12	12	12	12	10
1,25	20-19	12	12	14	14	15	15	14	12
1,5	16	15	15	17	17	18	18	17	15
1,75	14	17	17	19	19	21	21	18	17
2,0	12-11	19	20	22	22	25	25	20	18
2,5	10	22	24	26	26	31	31	22	20
3,0-3,5	8	28	30	32	32	38	38	24	22

Vorschubrichtung Innengewindedrehen

Feed direction internal threading

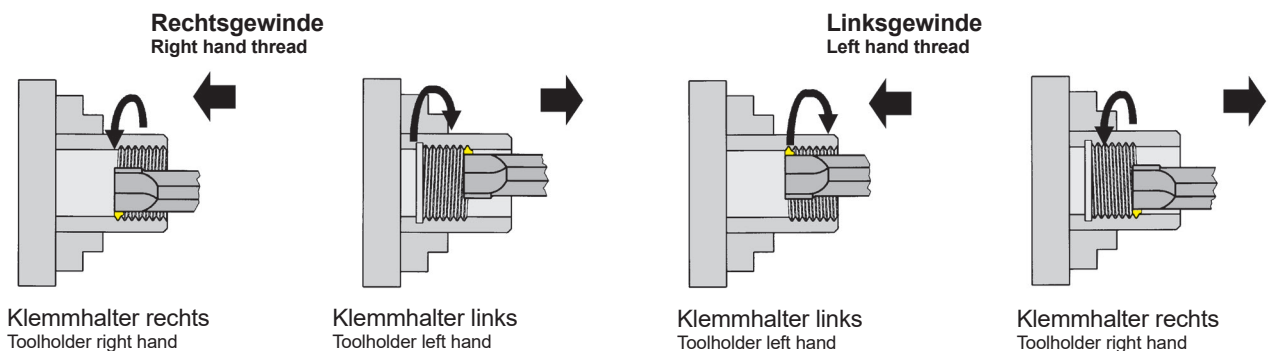

Zustellung

In-Feed

Radiale Zustellung

Radial In-Feed

Die gebräuchlichste Methode Gewinde herzustellen. Beide Schneiden sind gleichzeitig im Eingriff.

Metal removed on both sides of the insert simultaneously. The most commonly used method for thread production.



Modifizierte Flankenzustellung

Modified flank in-feed

Weniger Verschleiß der Schleppschiene und eine bessere Oberflächengüte der entsprechenden Gewindeflanke.

Less wear of the trailing edge and better surface finish on corresponding flank.



Wechselnde Flankenzustellung

Alternating flank in-feed

Beide Schneidflanken werden gleichmäßig benutzt, ergibt höhere Standzeiten.

Both edges are being fully utilised which means longer insert life.



Einseitige Flankenzustellung

Flank in-feed

Geringerer Schnittdruck und bessere Wärmeabfuhr.





More easily formed chip and better heat dissipation.





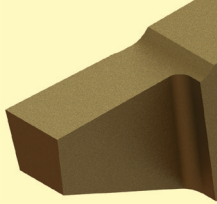
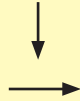
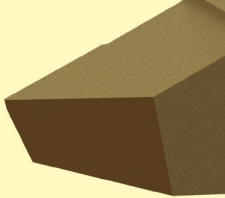

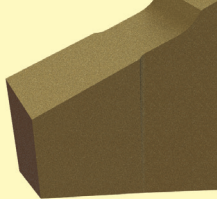
Geometrien und Vorschübe Typ S262

Geometries and feed rates type S262

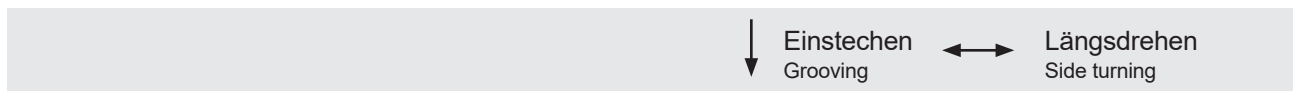

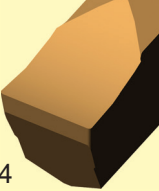
Geometrie Geometry	Einsatzgebiete Applications	Vorschub f (mm/U) Feed rate f (mm/rev)
	Einstechen und Rückwärtsdrehen Grooving and backturning	 0,01 - 0,10
	Längsdrehen und Kopierdrehen Side turning and profiling	 0,01 - 0,10
	Einstechen und Abstechen Grooving and parting off	 0,01 - 0,10

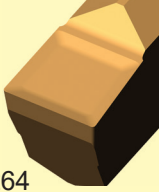



Geometrie Geometry	Einsatzgebiete Applications	Vorschub f (mm/U) Feed rate f (mm/rev)
.10  264	Einstecken und Abstechen Grooving and parting off	↓ 0,02 - 0,08
.20  264	Einstecken und Abstechen für hochfeste Werkstoffe Grooving and parting off for materials high tensile strength	↓ 0,02 - 0,08
.D1  S264	Einstecken und Längsdrehen Grooving and turning	↓ 0,03 - 0,13 ↔ 0,05 - 0,20 $a_{pmax} = 1,5 \times w$
.M0  264	Einstecken, Längsdrehen und Abstechen für Messing (Ms58) Grooving, turning and parting off for Brass (Ms58)	↓ 0,02 - 0,10 ↔ 0,02 - 0,15
.P.  264	Einstecken und Abstechen Grooving and parting off	↓ 0,02 - 0,08 ↔ 0,02 - 0,04 $a_{pmax} = 1,5 \times w$

↓ Einstecken Grooving ↔ Längsdrehen Side turning

Geometrien und Vorschübe Typ S274 / S274 μ

Geometries and feed rates type S274 / S274 μ



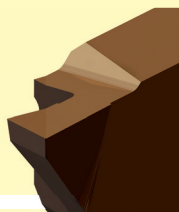
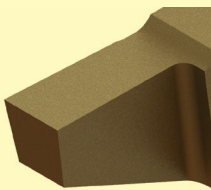
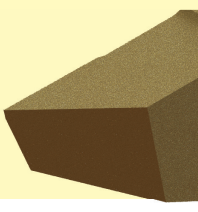
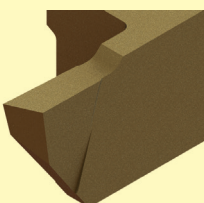

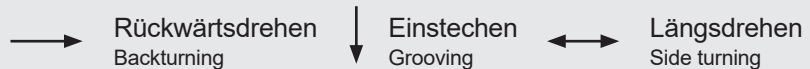
Geometrie Geometry	Einsatzgebiete Applications	Vorschub f (mm/U) Feed rate f (mm/rev)
.10 	Einstecken, Nuten schlichten, für langspanende Werkstoffe, "geringe Vorschübe" grooving, finishing of grooves, for long chipping materials, low feed rates	↓ 0,02 - 0,12
.M. 	Einstecken, Nuten schlichten, Geometrie für Form-WSP, kurzspanende und hochfeste Werkstoffe grooving, finishing of grooves, geometry for inserts with profile, for short chipping materials and high tensile strength	↓ 0,02 - 0,12
.P. 	Einstecken und Längsdrehen (in eine Richtung) Grooving and turning (in one direction)	↓ 0,02 - 0,10 ↔ 0,02 - 0,10
	Einstecken und Rückwärtsdrehen Grooving and backturning	↓ 0,002 - 0,01 →
	Längsdrehen und Kopierdrehen Side turning and profiling	↔ 0,002 - 0,02
	Abstechen Parting off	↓ 0,002 - 0,02



Geometrien und Vorschübe Typ 312 / S312

Geometries and feed rates type 312 / S312

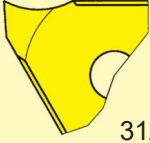
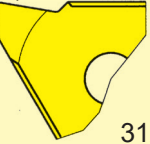
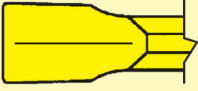
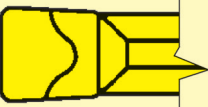
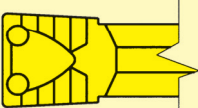
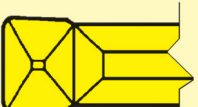

Geometrie Geometry	Einsatzgebiete Applications	Vorschub f (mm/U) Feed rate f (mm/rev)
.00  312	Einstecken, Nuten schlichten, für langspanende Werkstoffe, "geringe Vorschübe" grooving, finishing of grooves, for long chipping materials, low feed rates	↓ 0,02 - 0,12
Spanleitstufe für Sonder-WSP Chipbreaker for special inserts  312	Einstecken, Nuten schlichten, Geometrie für Form-WSP, kurzspanende und hochfeste Werkstoffe grooving, finishing of grooves, geometry for inserts with profile, for short chipping materials and high tensile strength	↓ 0,02 - 0,12
.V.  312	Einstecken, bei guter Spankontrolle grooving, with excellent chip control	↓ 0,04 - 0,15
.F.  S312	Einstecken, Kopieren von Nuten, leichter Schnitt grooving, profiling of grooves, easy cut	↓ 0,03 - 0,15
.5.  S312	Einstecken, Längsdrehen, Kopieren von Formnuten, ausgezeichnete Spanverjüngung bei Werkstoffen mittlerer Festigkeit grooving, side turning, profiling of grooves, excellent reduction of chip width in materials with medium tensile strength	↓ 0,08 - 0,25 ↔ 0,10 - 0,20*
.D.  S312	Einstecken, Kopieren von Formnuten, geeignet für Werkstoffe mit höherer Festigkeit grooving, profiling of grooves, suitable for materials with high tensile strength	↓ 0,03 - 0,15 ↔ 0,05 - 0,20
.C.  S312	Abstechen, Einstecken parting off, grooving	↓ 0,02 - 0,10

* abhängig von Schneidbreite, Eckenradius und Material
* dependent upon insert width, edge radii and material

↓ Einstecken Grooving ↔ Längsdrehen Side turning

Geometrien und Vorschübe Typ 32T

Geometries and feed rates type 32T

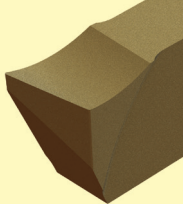
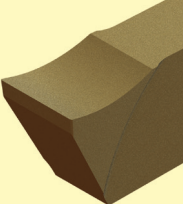
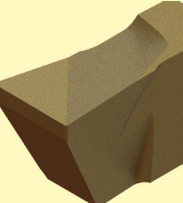

Geometrie Geometry	Einsatzgebiete Applications	Vorschub f (mm/U) Feed rate f (mm/rev)
<p>.10</p> 	<p>Einstechen und Abstechen grooving and parting off</p>	<p>↓ 0,02 - 0,10</p>
<p>.00</p> 	<p>Einstechen grooving</p>	<p>↓ 0,02 - 0,10</p>
<p>.P0</p> 	<p>Einstechen und Längsdrehen grooving and side turning</p>	<p>↓ ↔ 0,02 - 0,10</p>

Geometrien und Vorschübe für Aluminium

Geometries and feed rates for Aluminium

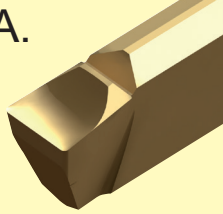

Geometrie Geometry	Einsatzgebiete Applications	Vorschub f (mm/U) Feed rate f (mm/rev)
<p>.WA.</p> 	<p>Einstecken und Abstecken, Nuten schlichten, leichter Schnitt</p> <p>Grooving and parting off, finishing of grooves, easy cut</p>	<p>↓ 0,07 - 0,25</p>

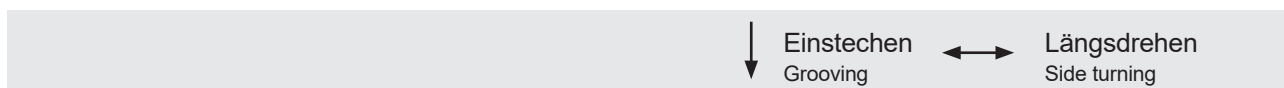

Geometrien und Vorschübe Abstechen

Geometries and feed rates Parting off



Geometrie Geometry	Einsatzgebiete Applications	Vorschub f (mm/U) Feed rate f (mm/rev)	Lieferbare Geometrien und Absteckschrägen Available geometries and lead angle								
			S100	S123/S223	S274	S264	S224	229/S229	312/S312	S315	S316
.00	Abstechen Parting off	0,02 - 0,10								0°	
		0,02 - 0,08								5°	
	Abstechen dünnwandiger Teile Tubes with small thickness	0,02 - 0,06				8°			8°		
		0,02 - 0,05			15°	15°			12°		
.00	Abstechen mit Spanformrille Parting off with chip former	0,02 - 0,15							0°		
		0,02 - 0,15							5°		
.M.	Abstechen spröder Materialien (MS58) Parting off brittle materials (MS58)	0,02 - 0,15							0°	0°	
		0,02 - 0,15							5°		
		0,02 - 0,12				8°					
		0,02 - 0,10				15°					
.V.	Abstechen mit Spanformung Parting off with chip forming	0,02 - 0,12							0°		
		0,02 - 0,08							5°		
.3V.	Abstechen Parting off	0,05 - 0,2	0°								
.C.	Abstechen Parting off	0,02 - 0,10		0°			0°	0°	0°		
		0,02 - 0,08		4°			5°	5°	5°		
		0,02 - 0,06		8°			8°	8°	8°		
		0,02 - 0,05		15°			15°				
.E.	Abstechen Parting off	0,02 - 0,12	0°				0°	0°			
		0,05 - 0,12	5°				5°				
.EN	Abstechen Parting off	0,10 - 0,25	0°				0°	0°		0°	
		0,10 - 0,20	5°								
*.D. (.32)	Abstechen Parting off	0,02 - 0,10		0°			0°	0°			
.F.	Abstechen Parting off	0,02 - 0,12	0°				0°	0°			
		0,02 - 0,10	5°				5°				
.3.	Abstechen Parting off	0,10 - 0,15					0°	0°			
		0,08 - 0,12						5°			
.N.	Abstechen Parting off	0,05 - 0,2	0°				0°				

* nur Schneidplatten S123 / S223

* only Inserts S123 / S223

Schnittdaten Supermini und Mini

Cutting data Supermini and Mini



			Vorschub f (mm/U) / Feed rate f (mm/rev)							
			Supermini®			Mini				
				0,01 - 0,02				0,01 - 0,03		
				0,02 - 0,05				0,03 - 0,10		
				0,02 - 0,05				0,01 - 0,08		
ISO	Material Material	Härte Brinell Hardness Brinell	Schnittgeschwindigkeit / Cutting speed v_c m/min							
			HB	MG12	EG55/35 ES15/1P	TH35*	AN25	IG35/36*	HS35/36	DD25
P	Kohlenstoffstahl Carbon steel	C < 0,4%	125							
		C > 0,4% < 0,6 %	150		160 200 - 14	170 210 - 14	160 200 - 14			
		C > 0,4% < 0,6 %	200							
	niedrig legierter Stahl low alloyed steel	geglüht annealed	180							
		vergütet quenched	275		140 180 - 16	160 200 - 16	160 200 - 16			
		vergütet quenched	300							
	hochlegierter Stahl high alloyed steel	geglüht annealed	200		80 120 - 19	100 140 - 19	100 140 - 19			
		vergütet quenched	325							
Stahlguss Cast steel	unlegiert unalloyed	180								
	niedrig legiert low alloyed	220		120 160 - 19	140 180 - 19	140 180 - 19				
	hoch legiert high alloyed	225								
M	Rostfreier Stahl Stainless steel	martensitisch ferritisch martensitic, ferritic	200		70 90 - 19			80 100 - 19	80 100 - 19	
		austenitisch austenitic	180					70 80 - 16	70 80 - 16	
K	Grauguss Grey cast iron		180-260		120 160 - 16	120 160 - 16				
	Kugelgraphitguss Spheroidal graphite cast iron		180-260		100 140 - 16	120 160 - 18				
	Temperguss Malleable cast iron		130-230		120 160 - 18	140 180 - 16				
S	Warmfeste Legierung Heat resistant alloy	NiFe						70 75 - 18	70 75 - 18	
		NiCo						35 40 - 18	35 40 - 18	
	Titan rein Titan pure		100					70 75 - 18		
	Titanlegierungen Titan alloys		266					70 75 - 18		
N	Al-Legierungen Al-alloys			14-220						180 220 - 14
	Kupfer- und Messinglegierung Copper and brass alloys			14-220						180 220 - 14
H	gehärtetes Material hardened material	> 54 HRC							40 50 - 30	

v_c ist abhängig vom Werkzeug- \varnothing und damit eingeschränkt durch die Höchstdrehzahl der Maschine.
 v_c is depending on the tool diameter and therefore of the maximum numbers of revolutions of the machine.

* Wenn nicht verfügbar, bitte TI25 oder TI26 einsetzen
 * If not available, please use TI25 or TI26

Schnittdaten Werkstoff P, M und K

Cutting data material P, M and K



Werkstoff Material		Härte Hardness Brinell (HB)	Schnittgeschwindigkeit v_c (m/min) Cutting speed v_c (m/min)								
			K10	EG35 EG55 ES15	HP65 HP66	IG35* IG36*	TH35 TH36	AS45 AS46 AS62 AS65 AS66	DD26	HS35 HS36	H20 H54
P	Kohlenstoffstahl Carbon steel	0,2% C	140	255 280-180	190 200-160		265 300-160	285 320-180			215 230-170
		0,4% C	180	225 250-140	170 180-150		235 270-130	255 290-150			205 220-160
		0,6% C	200	200 230-120	170 180-140		200 230-100	220 250-130			195 210-150
	Legierter Stahl Alloyed steel ($<5\%$)	geglüht annealed	180	190 220-100	170 180-140		200 220-90	200 230-100			195 210-150
		vergütet quenched	280	180 210-90	140 160-90		180 200-80	190 220-90			155 170-120
		vergütet quenched	350	165 190-80	130 140-90		150 180-80	170 200-80			125 140-80
	hochlegierter Stahl high alloyed steel ($>5\%$)	geglüht annealed	200	190 210-140	145 160-100		180 200-120	200 220-140			115 120-100
		gehärtet hardened	-	125 140-70						125 140-70	
	Stahlguss Cast steel	unlegiert unalloyed	180	185 200-140	160 180-120		180 200-140	190 200-150			165 180-120
		legiert alloyed	220	145 160-100	135 150-90		140 160-90	145 160-100			130 140-90
M	Rostfreier Stahl Stainless steel	martensitisch ferritisch martensitic, ferritic	200	125 130-100	100 120 - 80	100 120 - 80				145 180-120	175 190-120
		austenitisch austenitic	180		90 120 - 70	90 120 - 70				130 140-100	160 170-120
K	Grauguss Grey cast iron	niedrige Festigkeit low tensile strength	180	90-60	180 200-120			160 180-120	180 200-120		
		hohe Festigkeit high tensile strength	250	90-60	150 160-120			140 150-120	150 160-120		
	Kugelgraphit- guss Spheroidal graphite cast iron	ferritisch ferritic	160		170 180-130			160 180-120	170 180-130		
		perlitisch perlitic	250		150 160-120			140 150-110	150 160-120		
	Temperguss Malleable cast iron	ferritisch ferritic	125		200 220-120			180 200-100	200 220-120		
perlitisch perlitic		225		170 190-100			160 180-90	170 190-100			

Hinweise:

* Alternative: TI25 oder TI26

- Reduktion der Schnittgeschwindigkeit beim Axialstechen auf 75%
- Reduktion der Schnittgeschwindigkeit beim System 15A/25A auf 50%
- Reduktion der Schnittgeschwindigkeit beim Formstechen auf 75%
- Schneidstoffe mit Endung 2 oder 6 => tendenziell höhere Schnittgeschwindigkeit
- Schneidstoffe mit Endung 5 => tendenziell niedrigere Schnittgeschwindigkeit

Notes:

* Alternative: TI25 or TI26

- Reduction of the cutting speed for axial grooving to 75%.
- Reduction of the cutting speed of the 15A/25A system to 50%.
- Reduction of the cutting speed during form cutting to 75%.
- Cutting materials with suffix 2 or 6 => tendency to higher cutting speed
- Cutting materials with suffix 5 => tendency to lower cutting speed

Schnittdaten Werkstoff N und S

Cutting data material N and S



Werkstoff Material	Härte Hardness Brinell (HB)	Schnittgeschwindigkeit v_c (m/min) Cutting speed v_c (m/min)									
		K10	EG35 EG55 ES15	HP65 HP66	IG35* IG36*	TH35 TH36	AS45 AS46 AS62 AS65 AS66	DD26	HS35 HS36	H20 H54	
N	Al-Legierungen Al-alloys	nicht vergütbar not heat treatable	30-80	1000-600						900 1000-600	
		vergütbar heat treatable	80-120	400-220						350 400-220	
	Al-Guss-Legie- rung Al-cast-alloy	nicht vergütbar not heat treatable	80	1000-600						900 1000-600	
		vergütbar heat treatable	100	600-300						520 600-300	
	Kupfer-Legie- rungen Copper-alloys	nicht vergütbar not heat treatable	90	200-120						190 210-130	
		vergütbar heat treatable	100	150-90						145 160-90	
S	Warmfeste Legierung Heat resistant alloy (Fe)	geglüht annealed	200			85 100-40				85 100-40	
		gehärtet hardened	275			65 80-30				65 80-30	
	Warmfeste Legierung Heat resistant alloy (Ni, Co)	geglüht annealed	250			55 70-20				55 70-20	
		gehärtet hardened	350			45 60-10				45 60-10	
	Titan rein Titanium pure		100			70 90 - 60					
	Titanlegierungen Titanium alloys		266			70 90 - 60					

Hinweise:

* Alternative: TI25 oder TI26

- Reduktion der Schnittgeschwindigkeit beim Axialstechen auf 75%
- Reduktion der Schnittgeschwindigkeit beim System 15A/25A auf 50%
- Reduktion der Schnittgeschwindigkeit beim Formstechen auf 75%
- Schneidstoffe mit Endung 2 oder 6 => tendenziell höhere Schnittgeschwindigkeit
- Schneidstoffe mit Endung 5 => tendenziell niedrigere Schnittgeschwindigkeit

Notes:

* Alternative: TI25 or TI26

- Reduction of the cutting speed for axial grooving to 75%.
- Reduction of the cutting speed of the 15A/25A system to 50%.
- Reduction of the cutting speed during form cutting to 75%.
- Cutting materials with suffix 2 or 6 => tendency to higher cutting speed
- Cutting materials with suffix 5 => tendency to lower cutting speed



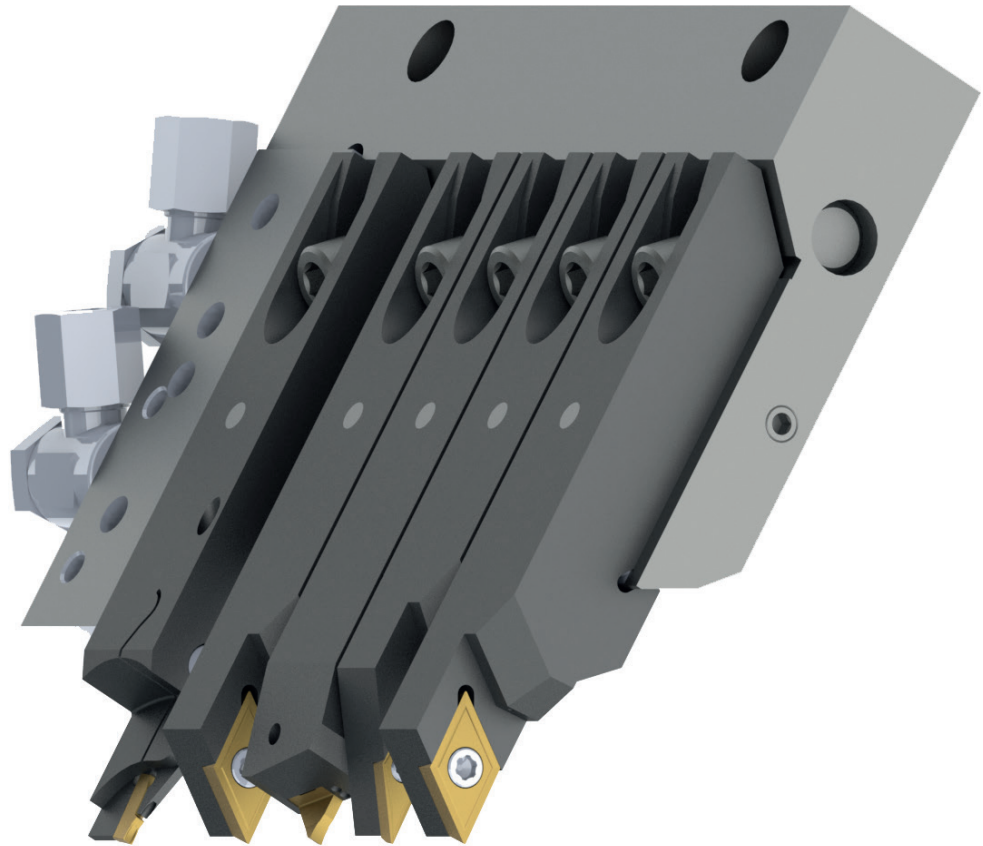

**Grundplatte und
Werkzeughalter**

**Base plate and
toolholder**

GRAF[®]
WERKZEUGSYSTEME

Schnellwechselsystem Lineareinheit

Quick change system Linear unit



Grundplatte

Base plate



mit innerer Kühlmittelzufuhr
with internal coolant

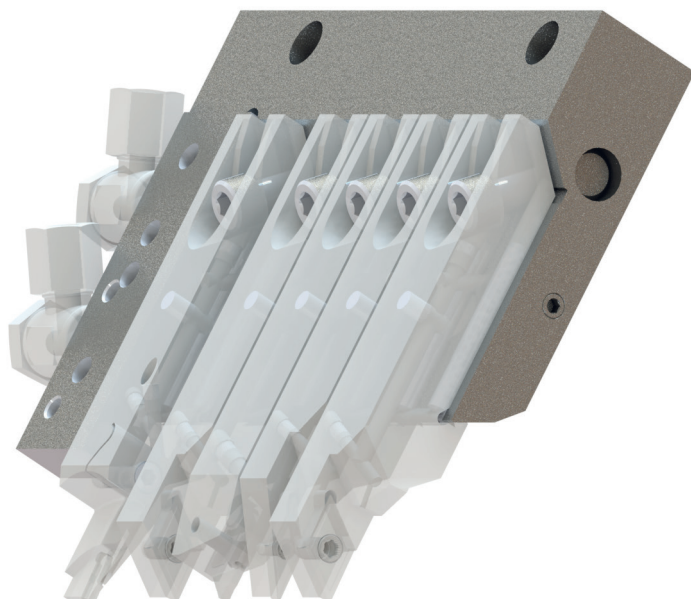

für Werkzeughalter GRAF
for Toolholder GRAF

Typ WZT
Type

Bestellnummer Graf Part number Graf	Bestellnummer HORN Part number HORN	max. Werkzeuge max. toolholder	Werkzeugträger Typ Toolholder Type	Maschinentyp Type of machine
22-0200	GPL.M16.01	5	V01	CITIZEN M16
22-0290	GPL.L20.01	5	V02	CITIZEN L20/A20
22-0250	GPL.SW12RII.01	5	V01	STAR SW12RII
22-0251	GPL.SW12RII.02	2	V01	STAR SW12RII
22-0275	GPL.SR20JII.01	6	V02	STAR SW12RII
22-0285	GPL.SR20RIV.01	5	V02	STAR SR20RIV
22-0286	GPL.SR20RIV.02	2	V02	STAR SR20RIV

Abmessungen in mm
Dimensions in mm

Werkzeughalter

Toolholder



mit innerer Kühlmittelzufuhr
with internal coolant

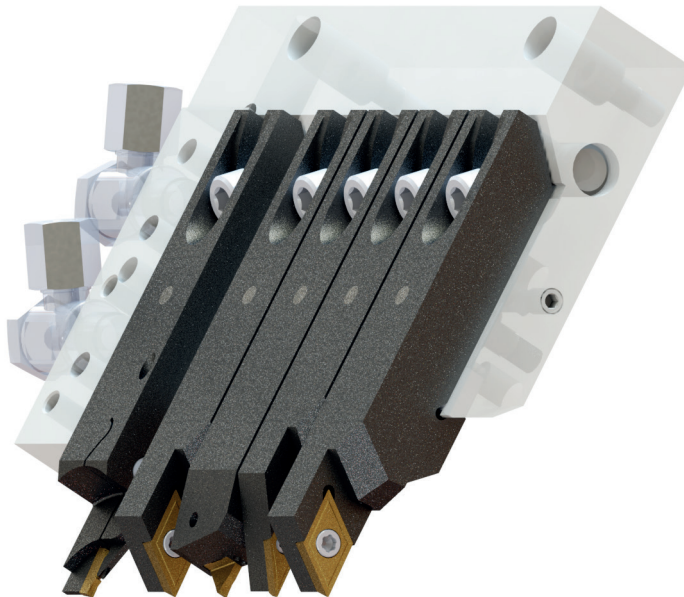

für Schneidplatten
for Inserts

Typ DC
Type CC
VC
S100
S101
RS274

Bestellnummer Graf Part number Graf	Bestellnummer HORN Part number HORN	Ausführung Version	Schneidplatte Insert	Werkzeugträger Typ Toolholder Type
22-0202	WZT.R.V01.002.DC11	rechts/right hand	DC..11 T3..	V01
22-0208	WZT.R.V01.008.CC09	rechts/right hand	CC..09 T3..	V01
22-0206	WZT.R.V01.006.VC11	rechts/right hand	VC..11 03..	V01
22-0210	WZT.L.V01.009.VC11	links/left hand	VC..11 03..	V01
22-0215	WZTN.V01.006.VC11	neutral	VC..11 03..	V01
22-0203	WZT.R.V01.003.S100	rechts/right hand	HORN Typ S100	V01
22-0211	WZT.R.V01.010.S101	rechts/right hand	HORN Typ S101	V01
22-0212	WZT.L.V01.011.S101	links/left hand	HORN Typ S101	V01
22-0213	WZT.R.V01.012.S274	rechts/right hand	HORN Typ S274	V01
22-0214	WZT.V01.BD.01	neutral	Platzhalter/Placeholder V01	V01
22-0239	WZT.R.V02.005.DC11	rechts/right hand	DC..11 T3..	V02
22-0326	WZT.YL.V02.003.DC11	links/left hand	DC..11 T3..	V02
22-0333	WZT.R.V02.009.CC09	rechts/right hand	CC..09 T3..	V02
22-0330	WZTN.V02.006.VC11	neutral	VC..11 03..	V02
22-0327	WZT.R.V02.004.S101	rechts/right hand	HORN Typ S101	V02
22-0325	WZT.YL.V02.002.S274	links/left hand	HORN Typ S274	V02
22-0328	WZT.V02.BD.01	neutral	Platzhalter/Placeholder V02	V02

Werkzeugträger können für alle Wendeschneidplatten hergestellt werden.
Sonderwerkzeuge sind auf Anfrage möglich.

Abmessungen in mm
Dimensions in mm

Toolholder can be produced for all inserts.
Special tools are available upon request..

Beispiel STAR SW12

Example STAR SW12

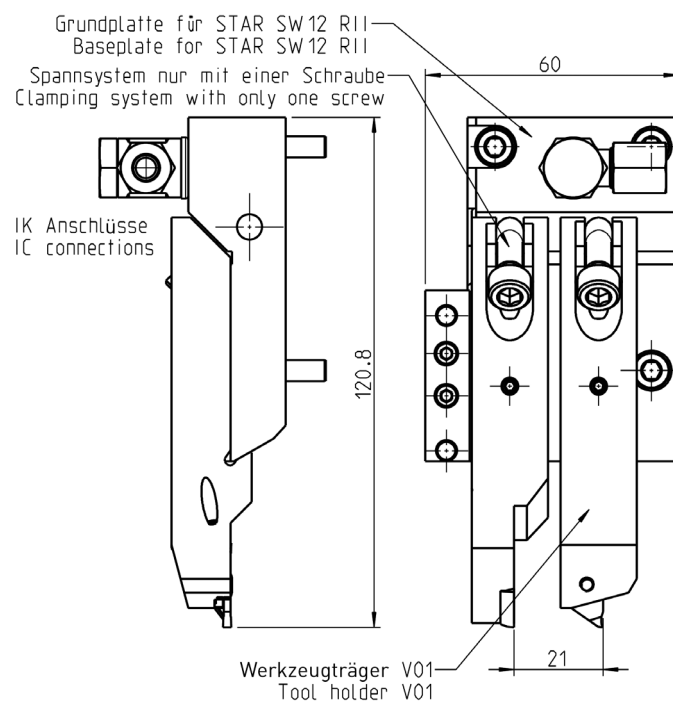
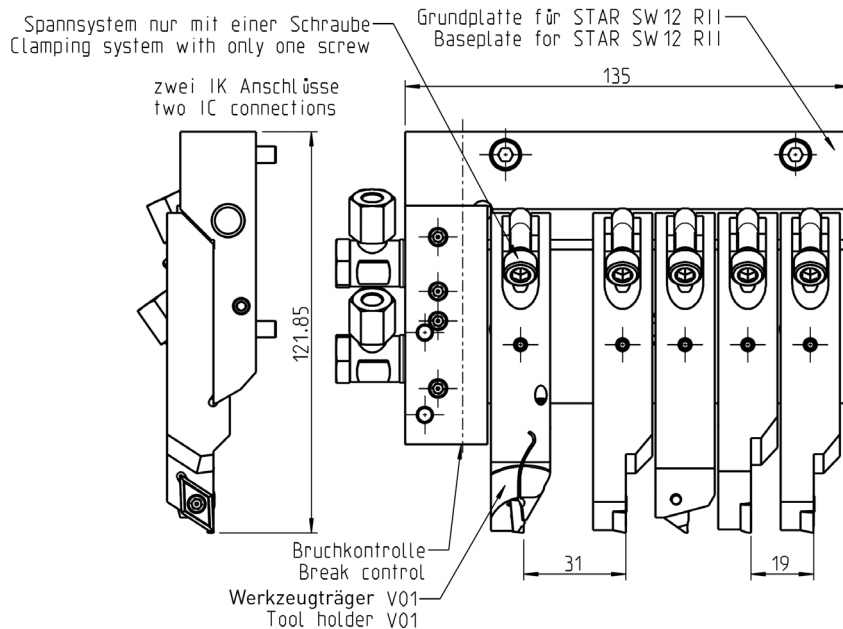

Abmessungen in mm
Dimensions in mm

Werkzeugträger können für alle Wendeschneidplatten hergestellt werden.
Sonderwerkzeuge sind auf Anfrage möglich.

Toolholder can be produced for all inserts.
Special tools are available upon request..

- **Optimierte Kühltechnologie:**
Der Kühlmittelstrahl tritt direkt an der Schneidzone aus, der Span wird unterspült und optimal abgeführt. Der Verschleiß wird erheblich reduziert und somit die Standzeiten erhöht. Individuelle Steuerung der Kühlmittelzufuhr sorgt für optimalen Kühlmiteleinsatz bei jedem einzelnen Werkzeugträger.
- **Minimierte Rüstzeiten:**
Das GRAF-System steht für ein einfaches Handling beim Werkzeugwechsel, somit werden die Nebenzeiten reduziert und die Produktivität erhöht.
Mit dem Einschraubsystem ist garantiert, dass der Werkzeugträger beim Werkzeugwechsel nicht herunterfällt.
- **Maximum an Präzisionstechnologie:**
Alle Werkzeugträger haben die gleiche Länge – keine zusätzliche Schnittstelle. Somit ist eine hohe Wechselgenauigkeit garantiert!
Für präzise Spannung der Werkzeugträger und maximale Stabilität sorgt die Schwalbenschwanz-Technologie. Die Innenkühlung erfolgt durch den Block und sorgt für eine platzsparende Lösung in der Maschine. Die kompletten Anschaffungskosten für Schläuche und Steckverbindungen entfallen.
- **Optimised cooling technology:**
The coolant jet emerges directly at the cutting zone. The chip is flushed out and optimally removed. Wear is considerably reduced and tool service life is increased.
Individual control of the coolant supply to each tool holder ensures optimal coolant use.
- **Minimised set-up times:**
The GRAF system simplifies tool change, reducing non-productive times and increasing productivity. The screw-in system guarantees that the toolholder does not fall when changing tools.
- **Maximum precision:**
All toolholder have the same length, with no additional interface, so high precision tool change is guaranteed! Dovetail technology ensures precise clamping of the tool carrier and maximum stability.
The coolant supply is internal through the block, ensuring a space-saving solution in the machine. The need to buy hoses and connectors is eliminated.

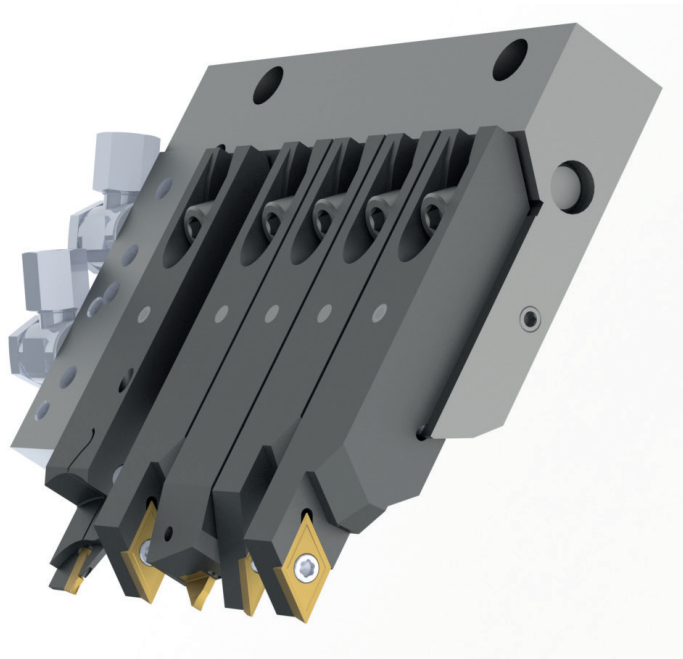

Weitere Informationen finden Sie in unserem Katalog
"HOCHLEISTUNGSWERKZEUGE".

Further information can be found in our catalogue
"HIGH PERFORMANCE TOOLS".



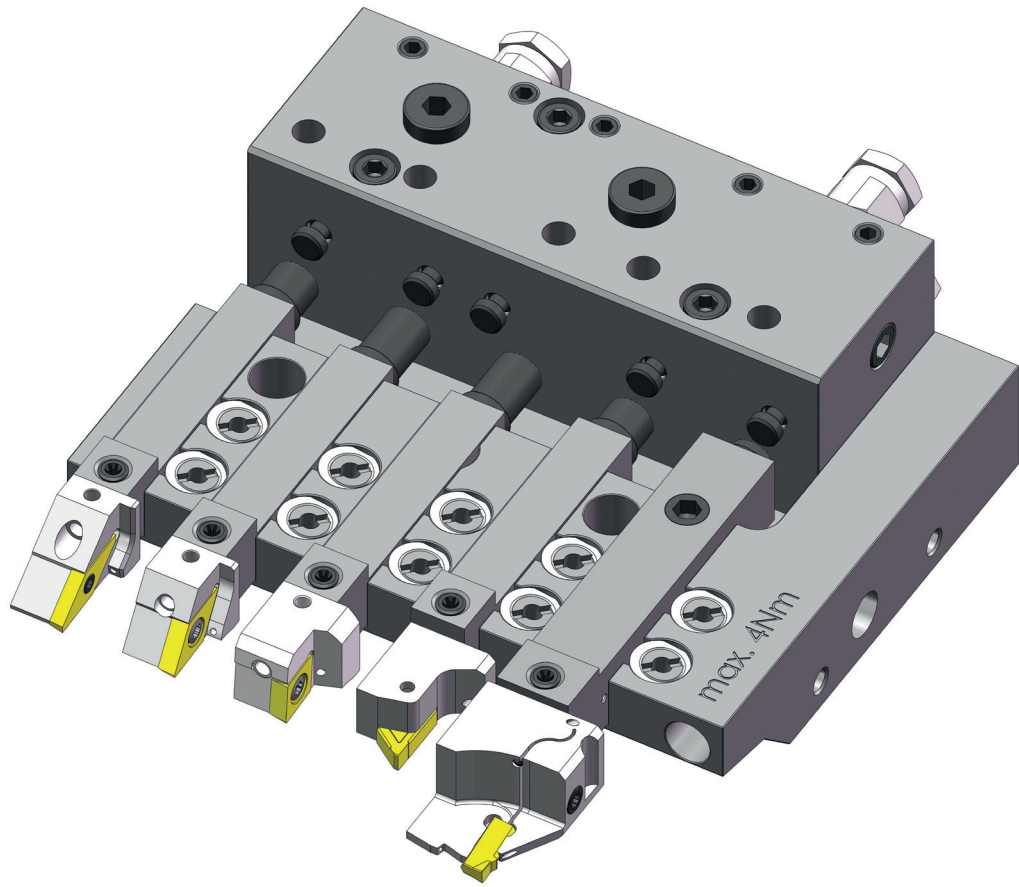

**Grundhalter für
Klemmhalter**

**Base holder
for toolholder**



Grundhalter

Base toolholder



mit innerer Kühlmittelzufuhr
with internal coolant

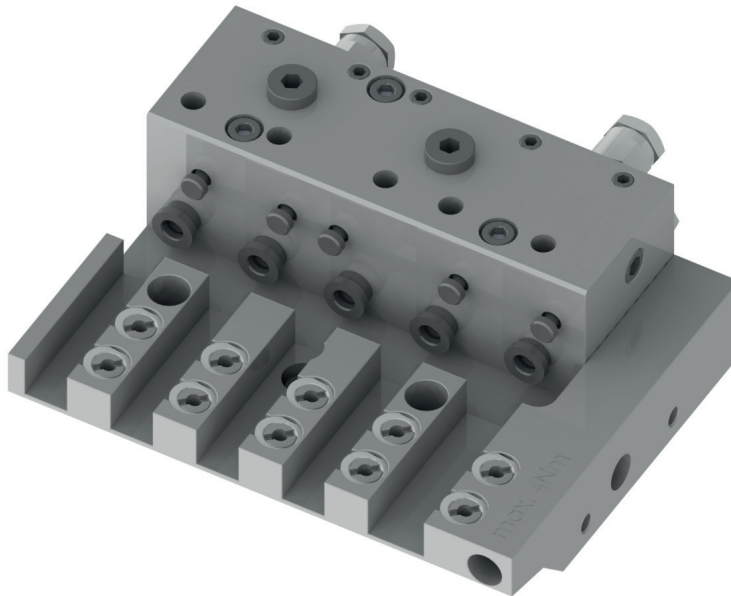

Bestellnummer Part number	Hersteller Manufacturer	Baureihe Version	Maschinentyp Type of machine			Modelgruppe Model group	Werkzeugplätze Tool places	Haltergröße Size of toolholder
KH.CI.AL20.1.5.1216.S	Citizen	AL20	L20E-2M8	L20E-2M12	A20-3F7N	1	5	12 x 16
KH.CI.L32.1.6.0016.S	Citizen	L32	L32-1M8	L32-1M10	L32-1M12	1	6	16 x 16
KH.CI.M16.1.5.0010.S	Citizen	M16	M16-4M5	M16-4M8		1	5	10 x 10
KH.CI.M32.1.50016.S	Citizen	M32	M32-4M5	M32-4M8		3	5	16 x 16
KH.GS.SP20.1.6.0012.S	DMG	SP20	SPRINT 20 8			1	6	12 x 12
KH.HA.XD2.1.6.0012.S	Hanwha	XD2	XD20II	XD26II		1	6	12 x 12
KH.ST.SR20.1.2.0012.S	Star	SR20	SR-20 RIV			1	2	12 x 12
KH.ST.SR20.1.5.0012.S	Star	SR20	SR-20 RIV			1	5	12 x 12
KH.ST.SR20.2.6.0016.S	Star	SR20	SR-20 JII			2	6	16 x 16
KH.ST.SR20.4.6.0012.S	Star	SR20	SR-20 RI	SR-20 RII		4	6	12 x 12
KH.ST.SR20.3.6.0012.S	Star	SR20	SR-20 RIII			3	6	12 x 12
KH.ST.SW12.1.2.0010.S	Star	SW12	SW-12 RII			1	2	10 x 10
KH.ST.SW12.1.5.0010.S	Star	SW12	SW-12 RII			1	5	10 x 10
KH.ST.SW20.1.4.0012.S	Star	SW20	SW-20			1	4	12 x 12
KH.ST.SW20.1.2.0012.S	Star	SW20	SW-20			1	2	12 x 12
KH.TS.B0126.1.3.0012.S	Tsugami	B0126	B0126-III			1	3	12 x 12
KH.TS.B0326.1.2.0016.S	Tsugami	B0326	B0326-III			1	2	16 x 16
KH.TS.B0326.1.5.0016.S	Tsugami	B0326	B0326-III			1	5	16 x 16

Werkzeugträger können für alle Wendeschneidplatten hergestellt werden.
Sonderwerkzeuge sind auf Anfrage möglich.

Abmessungen in mm
Dimensions in mm

Toolholder can be produced for all inserts.
Special tools are available upon request.

Funktionsprinzip am Beispiel Citizen L20

Functional principle using the example Citizen L20



- **Wirtschaftlich:**
Vorhandene Klemmhalter können herstellerunabhängig weiterhin eingesetzt werden. Auch Klemmhalter mit Innenkühlung sind uneingeschränkt einsetzbar.
- **Bedienerfreundlich:**
Die Lineareinheit ist 1:1 austauschbar mit der originalen Werkzeugplatte.
Sicheres und schnelles Spannen durch Einhand-Spannsystem. Klemmende Keile werden automatisch gelöst.
- **Durchdacht:**
KSS-Menge für jede Werkzeugstation individuell einstellbar. Die Übergabe des Kühlschmierstoffes erfolgt über ein flexibles Kühlmittelrohr. Durch überwiegend glatte Flächen und einem schlauchfeien Design, wird das Bilden von Spänenestern deutlich reduziert.
- **Flexibel:**
Jede Station verfügt über einen Werkzeuganschlag, welcher von 0-15mm bzw. von 10-25mm stufenlos einstellbar ist. Der Werkzeugkamm verfügt über verschiedene Kühlmittelanschlussmöglichkeiten, welche je nach Gegebenheiten an der Maschine verwendet werden können. Die Innenkühlung kann über zwei Zuleitungen für die Werkzeuge 1-3 und 4-5 oder über eine einzelne Zuleitung für alle erfolgen.

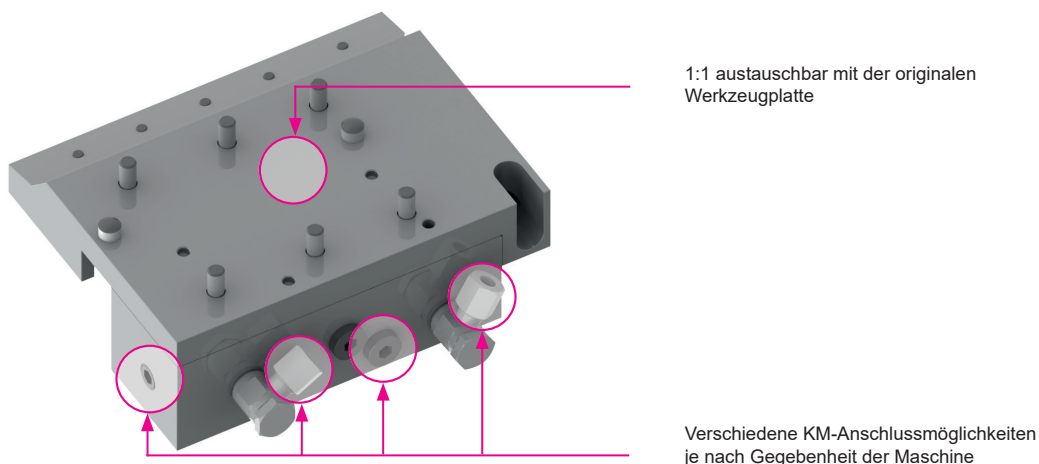
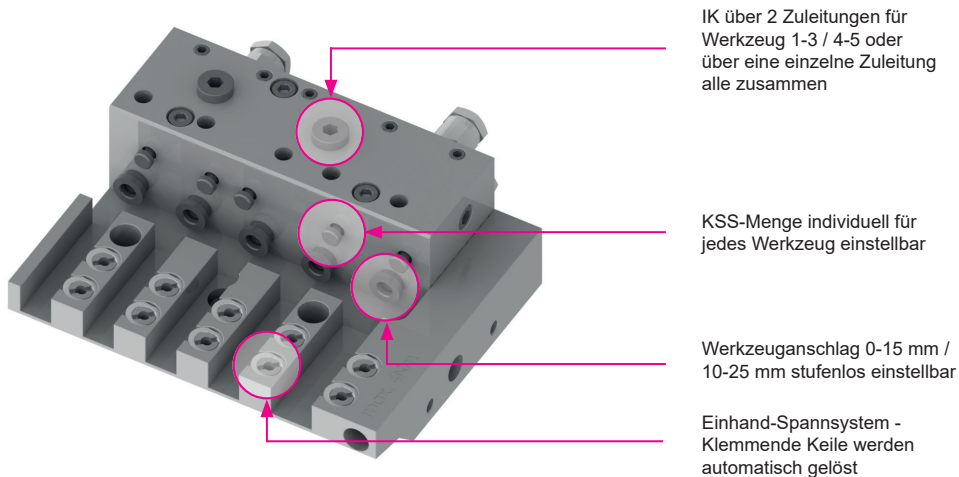



- Economically:**
 Already existing turning holders can still be used regardless of the manufacturer. Turning holders with IC can also be used with internal cooling without any restriction.
- User-friendly:**
 The linear unit is 1:1 interchangeable with the original tool plate. Safe and fast clamping with one-hand clamping system. Clamping wedges are automatically released.
- Smart:**
 Coolant quantity is individually adjustable for each tool station. The transfer of the cooling lubricant takes place via a flexible coolant pipe.
 Due to the mainly smooth surfaces and the hose free design, the formation of chip nests is significantly reduced.
- Flexible:**
 Each station has a tool stop, which is infinitely adjustable from 0-15mm or from 10-25mm.
 Linear unit has various coolant connection options, which can be used depending on the conditions on the machine.
 The internal cooling can be done via two supply lines for tools 1-3 and 4-5 or via a single supply line for all.

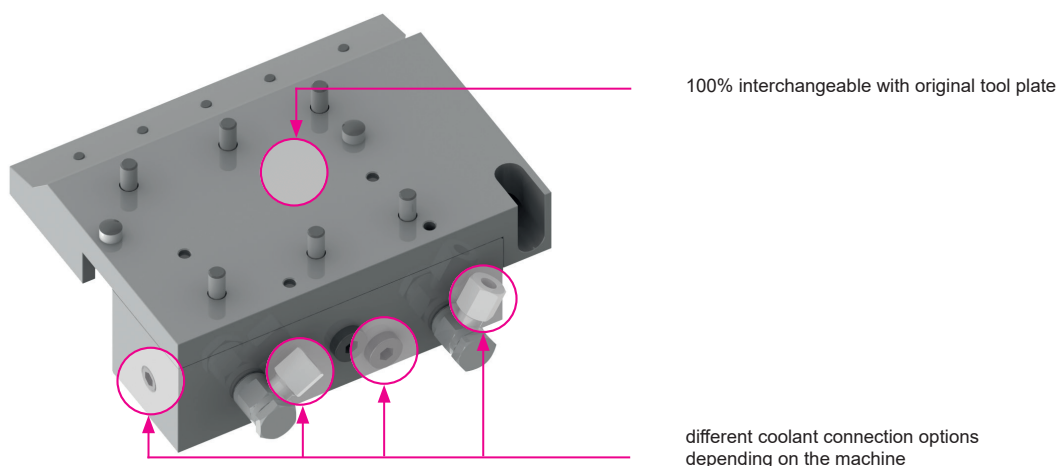
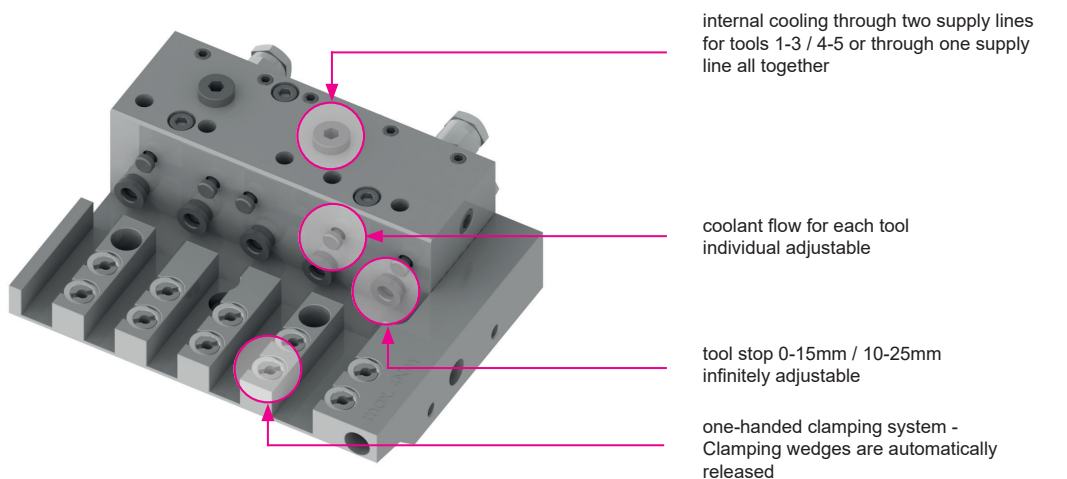

Weitere Informationen finden Sie im Katalog „MODULARE LANGDREHTECHNIK“.

Further informations can be found in the catalogue „MODULAR TECHNOLOGY FOR SWISS TYPE MACHINES“.







System	Seite/Page
Monoblock	L4
Monobloc	
Modular	L10
Modular	
JET-Wirbeln	L16
JET Whirling	
HORN Turbowirbeln®	L21
HORN Turbowhirling®	
High-Speed-Wirbeln	L25
High-Speed-Whirling	
Technische Hinweise	L27
Technical Instructions	

Gewindewirbelsysteme:

- Monoblock Systeme
Einteilige Gewindewirbelköpfe mit maximaler Präzision und Stabilität für alle gängigen Gewindewirbelapparate.
- Modulare Gewindewirbelsysteme
Zweiteiliges System mit Grundkörper und Ringkassette für höchste Wechselgenauigkeit. Einfaches Handling bedeutet kürzeste Rüstzeiten.
- JET-Wirbeln
Das einzige Werkzeug auf dem Markt mit Innenkühlung direkt auf die Schneide. Dies garantiert die Vermeidung von Spänestau und damit höchste Standzeiten und Oberflächengüten, bei sehr hohen Wechselgenauigkeiten.
- HORN Turbowirbeln®
Optimierter Zerpanungsprozess durch Schnittaufteilung. Höhere Schnittdaten und die Vermeidung von Spänestau, die Standzeiten erhöhen sich signifikant.
- High-Speed-Wirbeln
Die neue Technologie für kürzere Bearbeitungszeiten bietet hohe Produktivität durch parallele Dreh- und Wirbelbearbeitung. Das High-Speed-Wirbeln erfolgt mit unserem Maschinen- und Prozesstechnologiepartner Index / Traub.

Thread Whirling Systems:

- Monobloc Systems
Monobloc thread whirling heads with maximum precision and stability for all common thread whirling units.
- Modular Thread Whirling Systems
Two-part system with basic body and ring cassette for maximum change accuracy. Simple handling means shortest set-up times.
- JET Whirling
The only tool on the market with internal cooling directly to the cutting edge. This guarantees the avoidance of chip accumulation and maximum tool life and surface qualities, with very high exchange accuracies.
- HORN Turbowhirling®
Optimized cutting process by cutting division. Higher cutting data and the avoidance of chip accumulation, the downtime increases significantly.
- High-Speed-Whirling
The new technology for shorter processing times offers high productivity by parallel turning and whirling. The high-speed whirling takes place with our machine and process technology partner.

Gewindewirbeln Übersicht

Thread Whirling Overview



System	Einsatz	Vorteil	Schneidplatten
Monoblock Systeme Seite L4	Universell, eingängige und mehrgängige Gewinde	Einfache Handhabung Hohe Rundlaufgenauigkeit und Stabilität	S271 / S302 / S301
Modulare Systeme Seite L10	Universell, eingängige und mehrgängige Gewinde	Einfache Handhabung Niedrige Wechselzeiten Hohe Rundlaufgenauigkeit	S271
JET-Wirbeln Seite L16	Universell, Serienfertigung ein- und mehrgängiger Gewinde	Deutlich höhere Schnittdaten durch optimierte Kühlung. Hohe Standzeiten und höchste Oberflächengüten. Kein Spänestau, Zeitersparnis	S271 / S302
HORN Turbowirbeln® Seite L21	Hohe Spantiefen möglich, Serienfertigung ein- und mehrgängiger Gewinde	Schnittaufteilung - dadurch höhere Schnittdaten und Standzeiten, kein Spänestau	S271
High-Speed-Wirbeln Seite L25	Serienfertigung ein- und mehrgängiger Gewinde	Hohe Produktivität durch parallele Dreh- und Wirbelbearbeitung, hohe Standzeiten und Oberflächengüten	je nach Anforderung

System	Use	Benefit	Inserts
Monobloc Systems Page L4	Universal, single- and multi-start threads	Easy to handle, high concentricity and stability	S271 / S302 / S301
Modular Systems Page L10	Universal, single- and multi-start threads	Easy to handle Low change times High concentricity	S271
JET Whirling Page L16	Universal, serial production single and multi-start threads	Significantly higher cutting data through optimized cooling. Long tool life and highest surface qualities. No chip accumulation, time saving	S271 / S302
HORN Turbowhirling® Page L21	High cutting depths possible, serial production single- and multi-start threads	Devided cut thus higher cutting data and tool life, no chip accumulation	S271
High-Speed-Whirling Page L25	Serial production of single- and multi-start thread	High productivity through parallel turning and whirling, long tool life and surface qualities	depending on requirements

Wirbelkopf
Whirling Head
LM271/M271

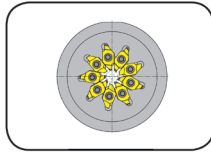

Seite/Page
L6, L8

Wirbelkopf
Whirling Head
LM302/M302

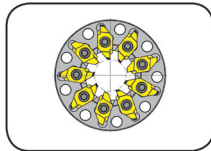

Seite/Page
L7, L9

www.phorn.de/produkte/gewindewirbeln/

KONFIGURATOR GEWINDEWIRBELN

Finden Sie das passende Werkzeug für Ihr System:

Maschine

Bitte wählen

Antriebseinheit

Bitte wählen

Suchen

THREAD WHIRLING CONFIGURATOR

Find the proper tool for your system:

Machine

Please Select

Whirling unit

Please Select

Search



271 / 302

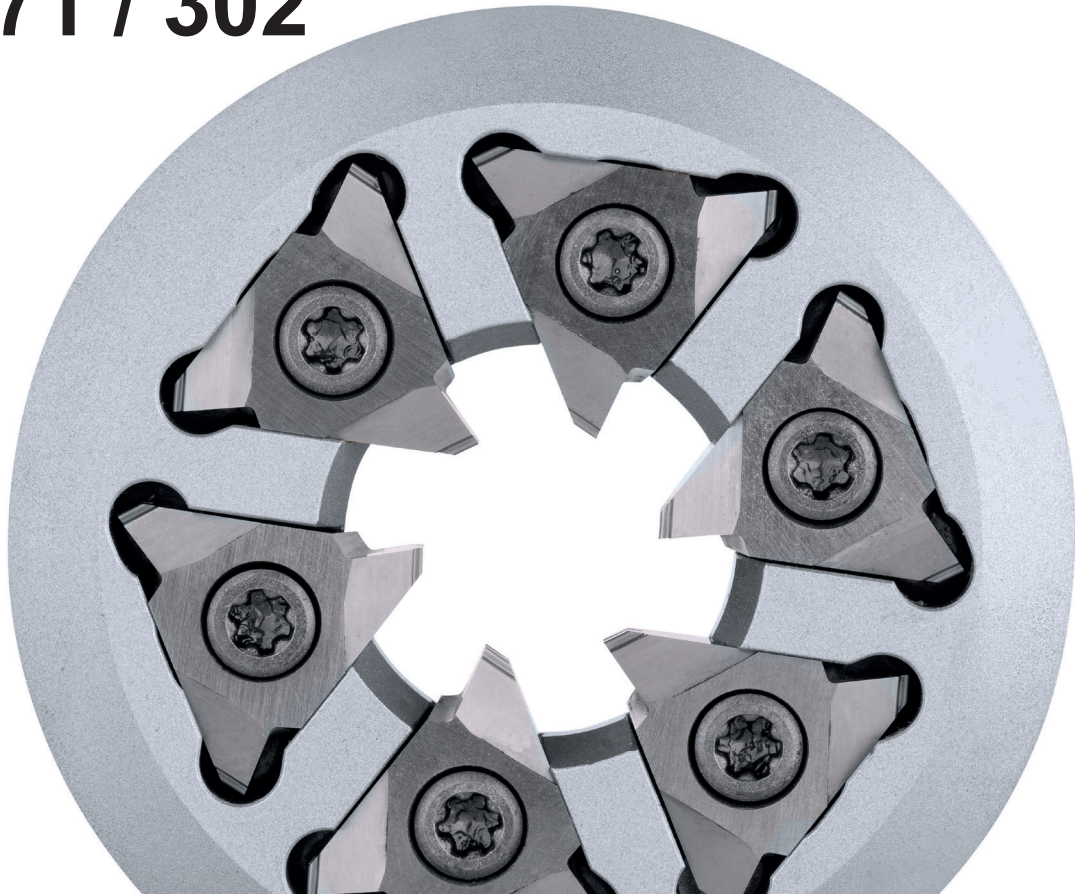

Monoblock System

Monobloc System

Gewindewirbeln Monoblock

Thread Whirling Monobloc System



L

Wirbelkopf

Whirling Head

LM271

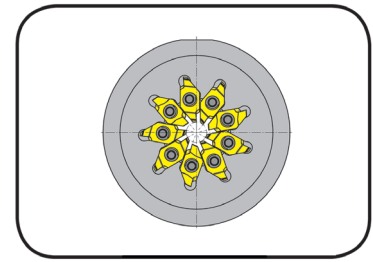

Einsatz für Wirbelapparat W&F
for W&F unit

für Schneidplatten
for Inserts

Typ S271
Type

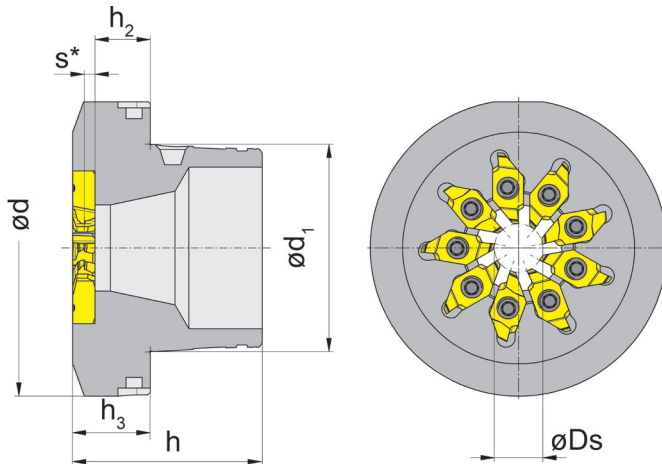

Bestellnummer Part number	Ds	d	d ₁	h	h ₃	h ₂	Z	Größe Size
LM271.06.WF01.14.4.9	6	55	38,5	30,15	9,4	5,25	9	04
LM271.09.WF01.14.4.9	9	55	38,5	30,15	9,4	5,25	9	04
LM271.12.WF01.14.4.9	12	55	38,5	30,15	9,4	5,25	9	04
LM271.06.WF01.15.4.9	6	55	38,5	35,15	14,4	10,25	9	04
LM271.09.WF01.15.4.9	9	55	38,5	35,15	14,4	10,25	9	04
LM271.12.WF01.15.4.9	12	55	38,5	35,15	14,4	10,25	9	04
LM271.06.WF01.18.4.9	6	55	38,5	39,15	18,4	14,25	9	04
LM271.09.WF01.18.4.9	9	55	38,5	39,15	18,4	14,25	9	04
LM271.12.WF01.18.4.9	12	55	38,5	39,15	18,4	14,25	9	04

*s ist abhängig von der Schneidplatte
*s depends on the insert

Abmessungen in mm
Dimensions in mm

Der Drehmomentschlüssel WFB.020.T15.PLUS zur Montage und der Exzenterschlüssel AG.MHS.WFW.001 zur Demontage des Wirbelkopfes sind nicht im Lieferumfang enthalten. Bitte separat bestellen.

The torque wrench WFB.020.T15.PLUS for mounting and the eccentric wrench AG.MHS.WFW.001 for dismantling the whirling head are not included. Please order separately.

Ersatzteile

Spare parts

Wirbelkopf Whirling Head	Spannschraube Clamping Screw	TORX PLUS®-Schlüssel TORX PLUS® Wrench
LM271...	030.2609.T8P	T8PL

Gewindewirbeln Monoblock

Thread Whirling Monobloc System



Wirbelkopf

Whirling Head

LM302

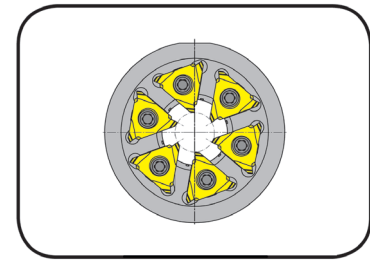

Einsatz für Wirbelapparat W&F
for W&F unit

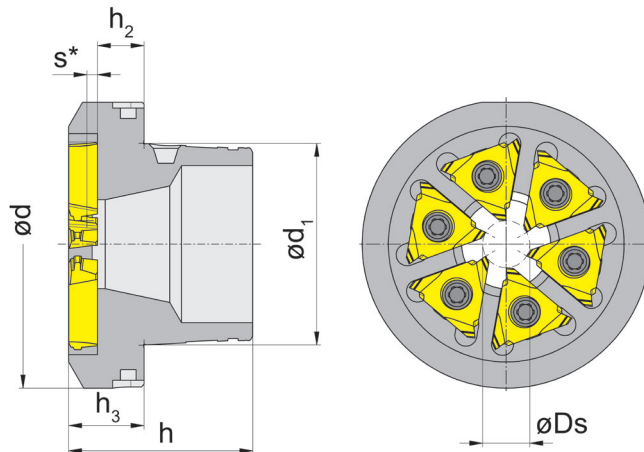

für Schneidplatten
for Inserts

Typ S302
Type

Bestellnummer Part number	Ds	d	d ₁	h	h ₂	h ₃	Z	Größe Size
LM302.06.WF01.10.5.6	6	55	38,5	31,50	5,25	10,75	6	05
LM302.06.WF01.15.5.6	6	55	38,5	35,15	8,90	14,40	6	05
LM302.06.WF01.18.5.6	6	55	38,5	39,15	12,90	18,40	6	05
LM302.09.WF01.10.5.6	9	55	38,5	31,50	5,25	10,75	6	05
LM302.09.WF01.15.5.6	9	55	38,5	35,15	8,90	14,40	6	05
LM302.09.WF01.18.5.6	9	55	38,5	39,15	12,90	18,40	6	05
LM302.12.WF01.10.5.6	12	55	38,5	31,50	5,25	10,75	6	05
LM302.12.WF01.15.5.6	12	55	38,5	35,15	8,90	14,40	6	05
LM302.12.WF01.18.5.6	12	55	38,5	39,15	12,90	18,40	6	05

*s ist abhängig von der Schneidplatte
*s depends on the insert

Abmessungen in mm
Dimensions in mm

Der Drehmomentschlüssel WFB.020.T15.PLUS zur Montage und der Exzenterschlüssel AG.MHS.WFW.001 zur Demontage des Wirbelkopfes sind nicht im Lieferumfang enthalten. Bitte separat bestellen.

The torque wrench WFB.020.T15.PLUS for mounting and the eccentric wrench AG.MHS.WFW.001 for dismounting the whirling head are not included. Please order separately.

Ersatzteile

Spare Parts

Wirbelkopf Whirling Head	Spannschraube Clamping Screw	TORX PLUS®-Schlüssel TORX PLUS® Wrench
LM302...	030.0412.T15P	T15PQ

Gewindewirbeln Monoblock

Thread Whirling Monobloc System



L

Wirbelkopf

Whirling Head

M271

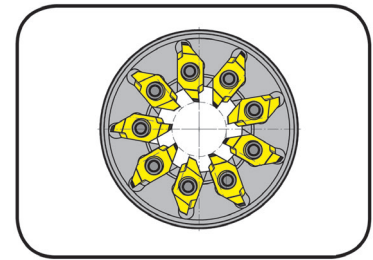

Einsatz für Wirbelapparat WTO
for whirling unit WTO

für Schneidplatten
for Inserts

Typ S271
Type

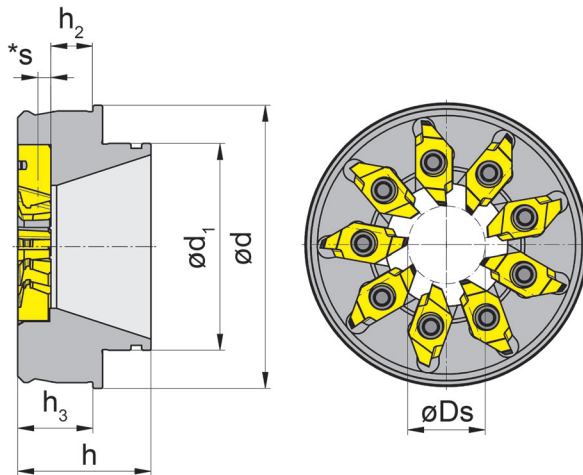

Bestellnummer Part number	Ds	h	h ₂	h ₃	d	Z	d ₁	Wirbelapparat Whirling Unit
M271.W012.32.09	12	20,65	8,5	13,15	43,8	9	32,0	WTO TN762004
M271.W012.54.09	12	15,15	10,5	13,65	54,0	9	43,8	WTO TN762006
M271.W022.54.09	22	15,15	10,5	13,65	54,0	9	43,8	WTO TN762006

*s ist abhängig von der Schneidplatte
*s depends on the insert

Abmessungen in mm
Dimensions in mm

Ersatzteile

Spare Parts

Wirbelkopf Whirling Head	Spannschraube Clamping Screw	TORX PLUS®-Schlüssel TORX PLUS® Wrench
M271...	030.2609.T8P	T8PL

Gewindewirbeln Monoblock

Thread Whirling Monobloc System



Wirbelkopf

Whirling Head

M302

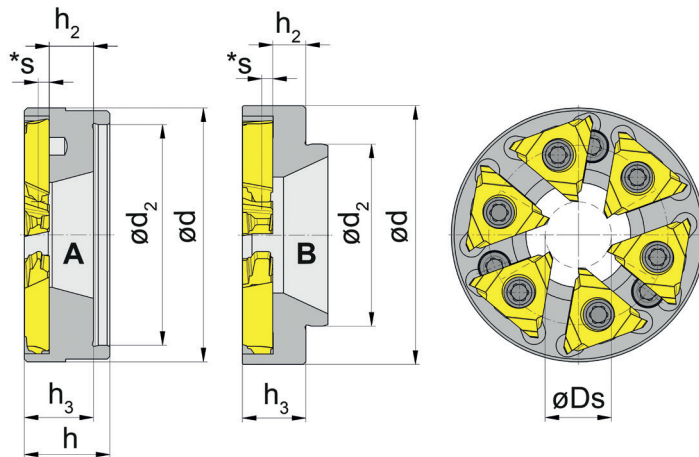
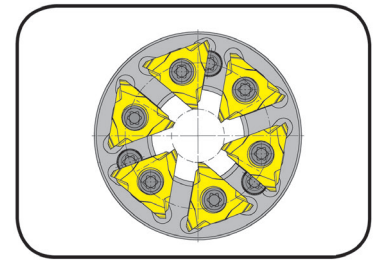

für Schneidplatten
for Inserts

Typ S302
Type

Bestellnummer Part number	Ds	h	h ₂	h ₃	d	Z	d ₂	Form Form
M302.A012.40.06	12	17,5	4,200	10,5	47,00	6	40,00	A
M302.C012.33.06	12	15,5	6,000	11,5	46,90	6	33,00	A
M302.C012.35.06	12	20,0	13,000	10,5	46,00	6	45,00	A
M302.C012.40.06	12	17,0	9,000	10,5	46,00	6	40,00	B
M302.C112.37.06	12	15,0	8,000	7,0	46,00	6	45,00	B
M302.C112.40.06	12	15,5	8,000	7,5	46,00	6	45,00	B
M302.T010.37.06	10	16,5	2,625	9,5	73,55	6	36,99	A
M302.T025.54.06	25	24,1	8,625	14,1	106,00	6	53,97	A
M302.W012.32.06	12	21,5	7,000	12,5	43,80	6	32,00	A
M302.W012.54.06	12	14,0	8,500	14,0	54,00	6	43,80	A

*s ist abhängig von der Schneidplatte
*s depends on the insert

Abmessungen in mm
Dimensions in mm

Ersatzteile

Spare Parts

Wirbelkopf Whirling Head	Spannschraube Wirbelkopf Clamping Screw Whirling Head	Spannschraube Schneidplatte Clamping Screw Inserts	TORX PLUS®-Schlüssel TORX PLUS® Wrench
M302.A012.40.06	030.400P.0655	030.0412 T15P	T15PQ
M302.C012.33.06	-	030.400P.0761	T15PQ
M302.C012.35.06	030.400P.0655	030.0412 T15P	T15PQ
M302.C012.40.06	030.400P.0655	030.0412 T15P	T15PQ
M302.C112.37.06	3.14T9P	030.0408.T15P	T9PL/T15PQ
M302.C112.40.06	030.400P.0708	030.0408.T15P	T15PQ
M302.T010.37.06	030.400P.0655	030.0412 T15P	T15PQ
M302.T025.54.06	-	030.0408.T15P	T15PQ
M302.W012.32.06	-	030.0411 T15P	T15PQ
M302.W012.54.06	-	030.400P.0761	T15PQ

Grundaufnahme
Basic Holder
LA002

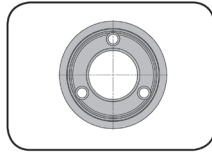

Seite/Page
L12

Ringkassette
Ring cassette
LM271

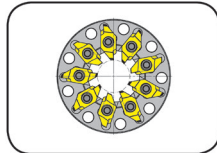

Seite/Page
L13

Wirbelkopf
Whirling Head
M302

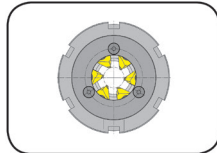

Seite/Page
L14

www.phorn.de/produkte/gewindewirbeln/

KONFIGURATOR GEWINDEWIRBELN

Finden Sie das passende Werkzeug für Ihr System:

Maschine

Bitte wählen

Antriebseinheit

Bitte wählen

Suchen

THREAD WHIRLING CONFIGURATOR

Find the proper tool for your system:

Machine

Please Select

Whirling unit

Please Select

Search

271 / 302



**Modulares
Gewindewirbeln**

**Modular thread
whirling system**

Grundaufnahme

Basic Holder

LA002

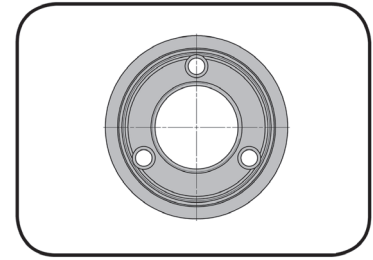

für Ringkassetten
for Ring Cassettes

Typ LM271
Type

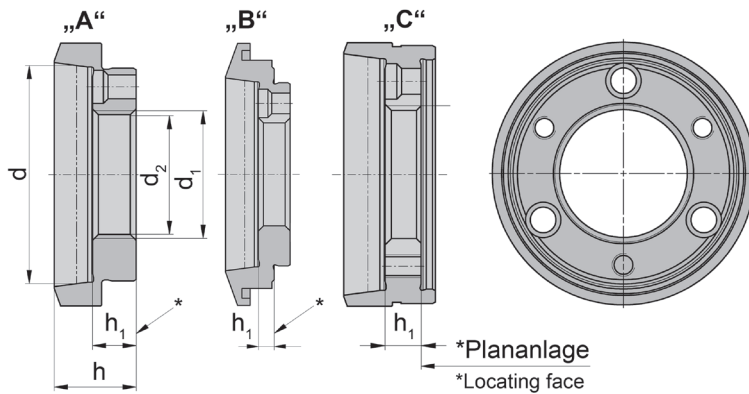

Bestellnummer Part number	d	d ₂	d ₁	h	h ₁	Ausführung Type
LA002.A040.4124.08	41	40,0	M24x1,5LH	15,40	8,20	A
LA002.A040.4124.13	41	40,0	M24x1,5LH	20,40	13,20	A
LA002.B033.4124.06	41	33,0	M24x1,5LH	16,00	6,30	C
LA002.B033.4124.11	41	33,0	M24x1,5LH	21,00	11,30	C
LA002.DP40.4124.03	41	40,0	M24x1,5LH	17,15	9,95	B
LA002.DP40.4124.08	41	40,0	M24x1,5LH	22,15	14,95	B
LA002.G042.4124.06	41	42,5	M24x1,5LH	13,15	5,95	B
LA002.G042.4124.11	41	42,5	M24x1,5LH	18,15	10,95	B
LA002.J037.4124.06	41	37,0	M24x1,5LH	16,50	6,30	C
LA002.J037.4124.11	41	37,0	M24x1,5LH	21,50	11,30	C
LA002.J040.4124.06	41	40,0	M24x1,5LH	16,00	6,30	C
LA002.J040.4124.11	41	40,0	M24x1,5LH	21,00	11,30	C
LA002.PC35.4124.10	41	35,0	M24x1,5LH	10,65	3,45	B
LA002.PC35.4124.15	41	35,0	M24x1,5LH	15,65	8,45	B
LA002.PC40.4124.06	41	40,0	M24x1,5LH	16,50	6,30	C
LA002.PC40.4124.11	41	40,0	M24x1,5LH	21,50	11,30	C

Abmessungen in mm
Dimensions in mm

Ersatzteile

Spare Parts

Grundaufnahme Basic Holder	Spannschraube Screw	TORX PLUS®-Schlüssel TORX PLUS® Wrench
LA002.A040.../...J040...	4.14T15P	T15PQ
LA002.PC040.../...DP40...	4.12T15EP	T15PQ
LA002.J037.4124.06	3.14T9P	T9PL
LA002.PC35.4124.10	4.16T15P	T15PQ

Ringkassette

Ring cassette

LM271

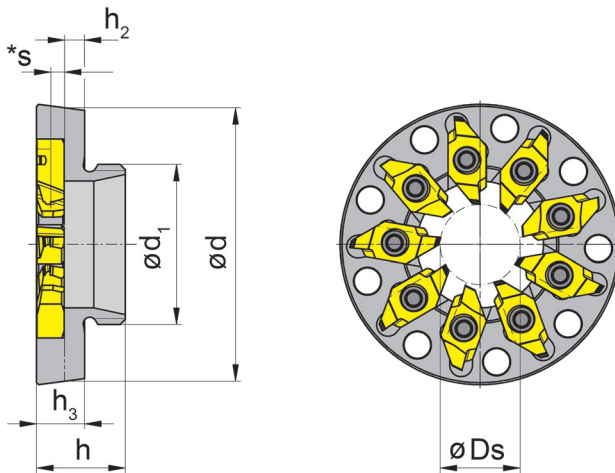
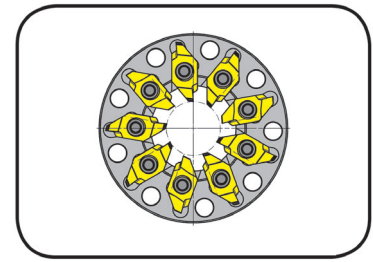

für Schneidplatten
for Inserts

Typ S271
Type

Bestellnummer Part number	Ds	d	d ₁	h	h ₃	h ₂	Z	Größe Size
LM271.06.4124.07.4.6	6	41	M24x1,5LH	13,3	7,2	3	6	04
LM271.06.4124.07.4.9	6	41	M24x1,5LH	13,3	7,2	3	9	04
LM271.09.4124.07.4.6	9	41	M24x1,5LH	13,3	7,2	3	6	04
LM271.09.4124.07.4.9	9	41	M24x1,5LH	13,3	7,2	3	9	04
LM271.12.4124.07.4.6	12	41	M24x1,5LH	13,3	7,2	3	6	04
LM271.12.4124.07.4.9	12	41	M24x1,5LH	13,3	7,2	3	6	04
LM271.12.4124.08.5.9	12	41	M24x1,5LH	14,3	8,2	3	9	05

*s ist abhängig von der Schneidplatte
*s depends on the insert

Abmessungen in mm
Dimensions in mm

Der Schlüssel 020.3504.5410 gehört nicht zum Lieferumfang der Ringkassette. Bitte separat bestellen!

Wrench 020.3504.5410 is not combined with the ring cassette - separate order required!

LM271...6 = konventionelles Wirbeln

LM271...9 = HORN Turbowhirling®

LM271...6 = conventional whirling

LM271...9 = HORN Turbowhirling®

Ersatzteile

Spare Parts

Ringkassette Ring cassette	Spannschraube Clamping Screw	TORX PLUS®-Schlüssel TORX PLUS® Wrench
LM271...	030.260P.1013	T8PL

Modulares Gewindewirbeln

Modular Thread Whirling



L

Wirbelkopf

Whirling Head

M302

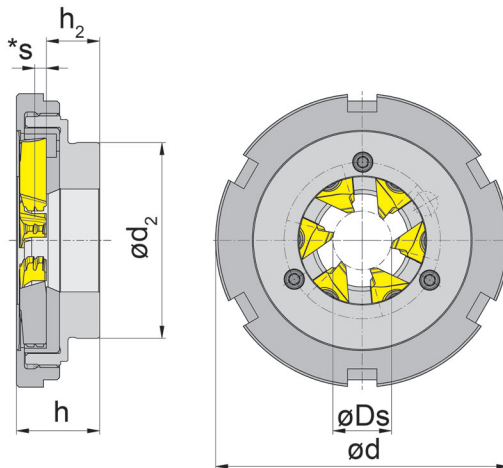
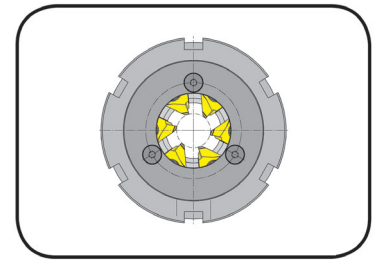

für Schneidplatten
for Inserts

Typ S302
Type

Bestellnummer Part number	Ds	h	h ₂	d	Z	d ₂
M302.AM12.40.06	12	20,7	14,4	52	6	40
M302.AM12.T.40.06	12	17,0	10,7	60	6	40
M302.DM11.0.40.06	11	20,5	8,5	60	6	40

*s ist abhängig von der Schneidplatte
*s depends on the insert

Abmessungen in mm
Dimensions in mm

Ersatzteile

Spare Parts

Wirbelkopf Whirling Head	Spannschraube Clamping Screw	Spannschraube Clamping Screw	TORX PLUS®-Schlüssel TORX PLUS® Wrench	Grundaufnahme Basic Holder	Inbus-Schlüssel Allen Wrench
M302.AM12.40.06	030.400P.0708	030.0412.T15P	T15PQ	-	-
M302.AM12.T.40.06	-	-	T8PL	002.4640.1634	-
M302.DM11.0.40.06	-	-	T15PQ	002.4540.1620	SW2,0 DIN911



Wirbelkopf
Whirling Head
LM271

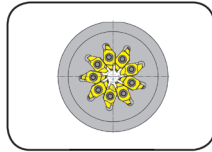

Seite/Page
L18

Wirbelkopf
Whirling Head
LM302

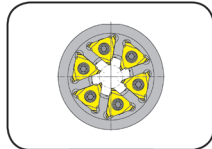

Seite/Page
L19

www.phorn.de/produkte/gewindewirbeln/

KONFIGURATOR GEWINDEWIRBELN

Finden Sie das passende Werkzeug für Ihr System:

Maschine

Bitte wählen

Antriebseinheit

Bitte wählen

Suchen

THREAD WHIRLING CONFIGURATOR

Find the proper tool for your system:

Machine

Please Select

Whirling unit

Please Select

Search



JET-Wirbeln

- Einziges Wirbelwerkzeug mit innerer Kühlmittelzufuhr
- Hohe Standzeit und Oberflächengüten
- Hohe Wechselgenauigkeit beim Wechsel des Wirbelkopfes

JET Whirling

- The only whirling tool to feature an internal coolant supply
- Long tool life and excellent surface quality thanks to targeted cooling of the cutting zone
- Accurate indexability when changing the whirling head owing to the precise interface

Wirbelkopf

Whirling Head

LM271

mit innerer Kühlmittelzufuhr
with through coolant supply

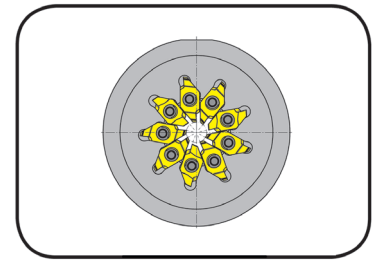

Einsatz nur für W&F JET-Wirbelapparat
Use only for W&F JET whirling unit

für Schneidplatten
for Inserts

Typ S271
Type

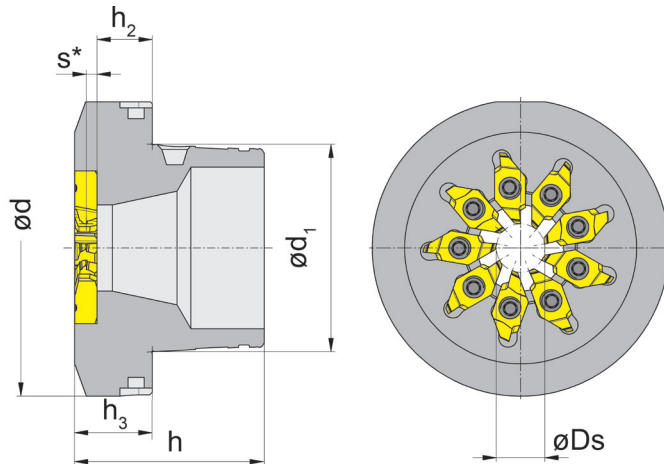

Bestellnummer Part number	Ds	d	d ₁	h	h ₂	h ₃	Z	Größe Size
LM271.06.WF01.14.4.9.IK	6	55	38,5	30,15	5,25	9,4	9	04
LM271.09.WF01.14.4.9.IK	9	55	38,5	30,15	5,25	9,4	9	04
LM271.12.WF01.14.4.9.IK	12	55	38,5	30,15	5,25	9,4	9	04
LM271.06.WF01.15.4.9.IK	6	55	38,5	35,15	10,25	14,4	9	04
LM271.09.WF01.15.4.9.IK	9	55	38,5	35,15	10,25	14,4	9	04
LM271.12.WF01.15.4.9.IK	12	55	38,5	35,15	10,25	14,4	9	04
LM271.06.WF01.18.4.9.IK	6	55	38,5	39,15	14,25	18,4	9	04
LM271.09.WF01.18.4.9.IK	9	55	38,5	39,15	14,25	18,4	9	04
LM271.12.WF01.18.4.9.IK	12	55	38,5	39,15	14,25	18,4	9	04

*s ist abhängig von der Schneidplatte
*s depends on the insert

Abmessungen in mm
Dimensions in mm

Der Drehmomentschlüssel WFB.020.T15.PLUS zur Montage und der Exzenterschlüssel AG.MHS.WFW.001 zur Demontage des Wirbelkopfes sind nicht im Lieferumfang enthalten. Bitte separat bestellen.

The torque wrench WFB.020.T15.PLUS for mounting and the eccentric wrench AG.MHS.WFW.001 for dismantling the whirling head are not included. Please order separately.

Ersatzteile

Spare Parts

Wirbelkopf Whirling Head	Spannschraube Clamping Screw	TORX PLUS®-Schlüssel TORX PLUS® Wrench
LM271...	030.2609.T8P	T8PL



Wirbelkopf

Whirling Head

LM302

mit innerer Kühlmittelzufuhr
with through coolant supply

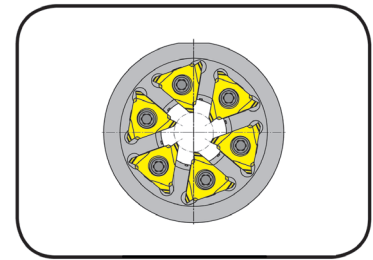

Einsatz nur für W&F JET-Wirbelapparat
Use only for W&F JET whirling unit

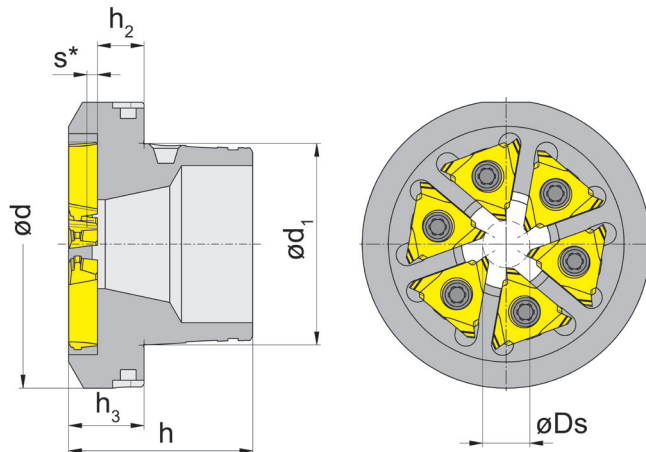

für Schneidplatten
for Inserts

Typ S302
Type

Bestellnummer Part number	Ds	d	d ₁	h	h ₂	h ₃	Z	Größe Size
LM302.06.WF01.10.5.6.IK	6	55	38,5	31,50	5,25	10,75	6	05
LM302.09.WF01.10.5.6.IK	9	55	38,5	31,50	5,25	10,75	6	05
LM302.12.WF01.10.5.6.IK	12	55	38,5	31,50	5,25	10,75	6	05
LM302.06.WF01.15.5.6.IK	6	55	38,5	35,15	8,90	14,40	6	05
LM302.09.WF01.15.5.6.IK	9	55	38,5	35,15	8,90	14,40	6	05
LM302.12.WF01.15.5.6.IK	12	55	38,5	35,15	8,90	14,40	6	05
LM302.06.WF01.18.5.6.IK	6	55	38,5	39,15	12,90	18,40	6	05
LM302.09.WF01.18.5.6.IK	9	55	38,5	39,15	12,90	18,40	6	05
LM302.12.WF01.18.5.6.IK	12	55	38,5	39,15	12,90	18,40	6	05

*s ist abhängig von der Schneidplatte
*s depends on the insert

Abmessungen in mm
Dimensions in mm

Der Drehmomentschlüssel WFB.020.T15.PLUS zur Montage und der Exzenterschlüssel AG.MHS.WFW.001 zur Demontage des Wirbelkopfes sind nicht im Lieferumfang enthalten. Bitte separat bestellen.

The torque wrench WFB.020.T15.PLUS for mounting and the eccentric wrench AG.MHS.WFW.001 for dismounting the whirling head are not included. Please order separately.

Ersatzteile

Spare Parts

Wirbelkopf Whirling Head	Spannschraube Clamping Screw	TORX PLUS®-Schlüssel TORX PLUS® Wrench
LM302...	030.0412 T15P	T15PQ

Durch die hohe Rundlaufgenauigkeit der Schnittstelle und der gleichmäßigen Abnutzung der Schneidplatten, kann eine signifikante Standzeiterhöhung erreicht werden.

Wechseln des Einsatzes:	< 1 min
Rundlaufgenauigkeit:	< 3 μ
Wechselwiederholgenauigkeit:	< 2 μ
max. Drehzahl:	8.000 U/min
Innenkühlung:	80 bar
Verstellbereich:	+/- 20°

Verfügbar für alle gängigen Langdrehmaschinen.

Due to the high concentricity of the interface and the even wear of the inserts, a significant increase in tool life can be achieved.

Changing the insert:	< 1 min
Concentricity:	< 3 μ
Repeatability of changes:	< 2 μ
Rotation speed max:	8.000 U/min
Internal coolant:	80 bar
Adjustment range:	+/- 20°

Available for all common Swiss type machines.



Durch das Zusammenspiel von Kegel-Plananlage mit zylindrischem Bund, erreichen wir höchste Genauigkeit in der Schnittstelle und ebenso ein bedienerfreundliches Wechseln der Einsätze mit lediglich drei Schrauben.

Due to the interplay of conical face plant with cylindrical collar, we achieve the highest accuracy in the interface as well as user-friendly replacement of the inserts with only three screws.

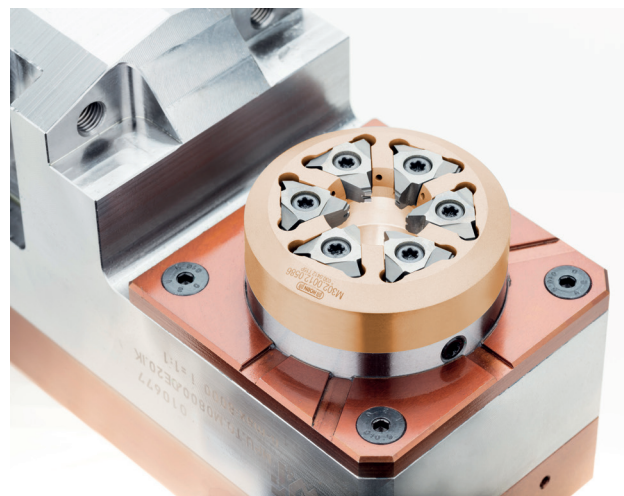



**HORN
Turbowirbeln®**

**Doppelt so schnell bei
erhöhter Standzeit!**

Vor- und Fertigwirbeln
in einem Prozess

**HORN
Turbo whirling®**

**Twice as fast with
higher tool life**

Pre- and finish whirling
in a single process

L



HORN

Turbowirbeln®

Der neu entwickelte Prozess des HORN Turbowirbelns® optimiert die Zerspanung beim Gewindewirbeln und erhöht die Wirtschaftlichkeit. Speziell zur Bearbeitung von Gewinden mit größerem Aufmaß entwickelte HORN Schneidwerkzeuge für das Wirbeln mit neuer Schnittaufteilung. Einzelne Schneiden arbeiten dazu als Vorschneider und zerspanen das Werkstück bis zum definierten Außendurchmesser. Bei neuschneidigen Werkzeugen wird über Schnittaufteilung die Zerspanungsarbeit so aufgeteilt, dass jede Schneide gleichmäßig belastet wird und dadurch die einzelnen Schneiden signifikant höhere Standzeiten erzielen. Die Schlichtschneiden erzeugen im optimierten Arbeitsbereich die fertigen Gewindeflanken. Unabhängig vom Werkstückaußendurchmesser entsteht durch die Kombination unterschiedlicher Schneidenprofile so ein optimales Gewinde mit reproduzierbaren Standmengen.

Das HORN Turbowirbeln ist anwendbar bei ein- und mehrgängigen Gewinden und Profilen. Die präzisionsgeschliffenen zweischneidigen Wendeschneidplatten vom Typ S271 werden dabei individuell auf das jeweilige Gewindeprofil und den zu zerspanenden Werkstoff abgestimmt. Gespannt werden die Wendeschneidplatten in formschlüssigen, extrem stabilen Plattensitzen, entweder in den neuen modularen Wirbelköpfen mit optimiertem Handling beim Plattenwechsel, oder konventionell in den Monoblock-Werkzeugen.

HORN

Turbo whirling®

The newly developed HORN turbo whirling® process optimises machining during thread whirling and increases efficiency. HORN has developed cutting tools for whirling with a new cutting division specially for machining threads with a larger allowance. To this end, individual cutting edges work as pre-cutters and machine the workpiece to the defined external diameter. In the case of nine-cutter tools, the cutting division allows the machining work to be divided so that each cutting edge is subject to equal load, meaning that individual cutting edges can achieve significantly higher service lives. The finishing cutting edges produce the finished thread flanks within the optimised working range. Regardless of the external workpiece diameter, combining a range of cutting edge profiles creates an optimum thread with reproducible tool life.

HORN turbo whirling can be applied to single-start and multi-start threads and profiles. What's more, during this process, the S271 precision-ground double-edged indexable inserts are tailored to the respective thread profile and the material to be machined. The indexable inserts are clamped in positive-fit, extremely stable insert seats either in the new modular whirling heads with optimised handling during insert replacement or conventionally in the Mono block tools.



L



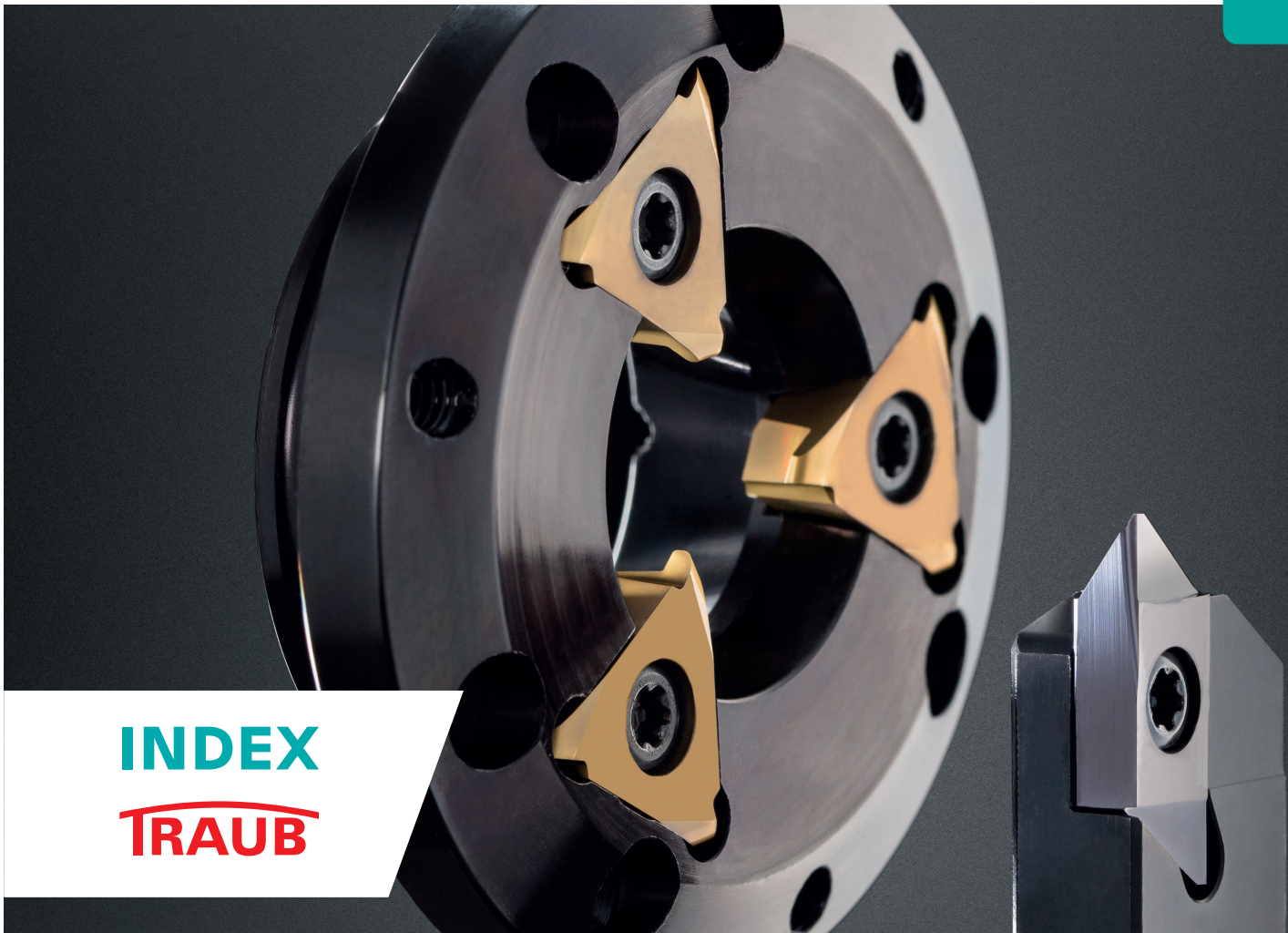

INDEX
TRAUB

High-Speed-Wirbeln

neue Technologie für kürzere
Bearbeitungszeiten

High-Speed-Whirling

new technology for shorter
machining times

- Hohe Produktivität durch parallele Dreh- und Wirbelbearbeitung
- Hohe Standzeiten und Oberflächengüten
- Maschinen- und Prozess-technologiepartner Index / Traub
- High productivity through turning and whirling operations performed simultaneously
- Long tool life and excellent surface quality as a result of pre-turning the thread diameter
- Machine and process technology partners Index / Traub

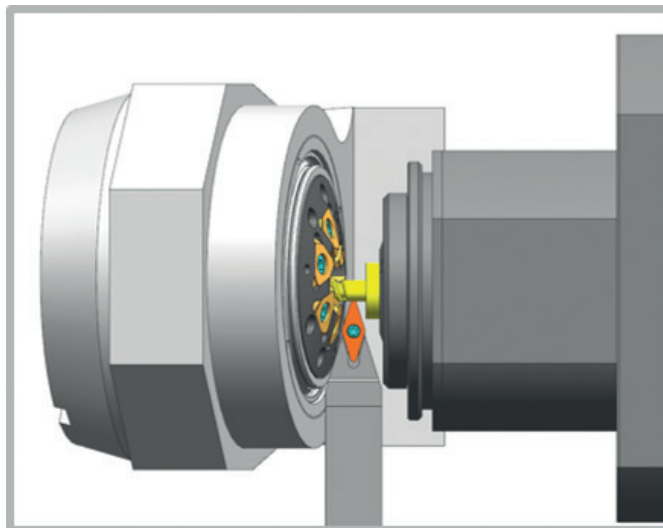

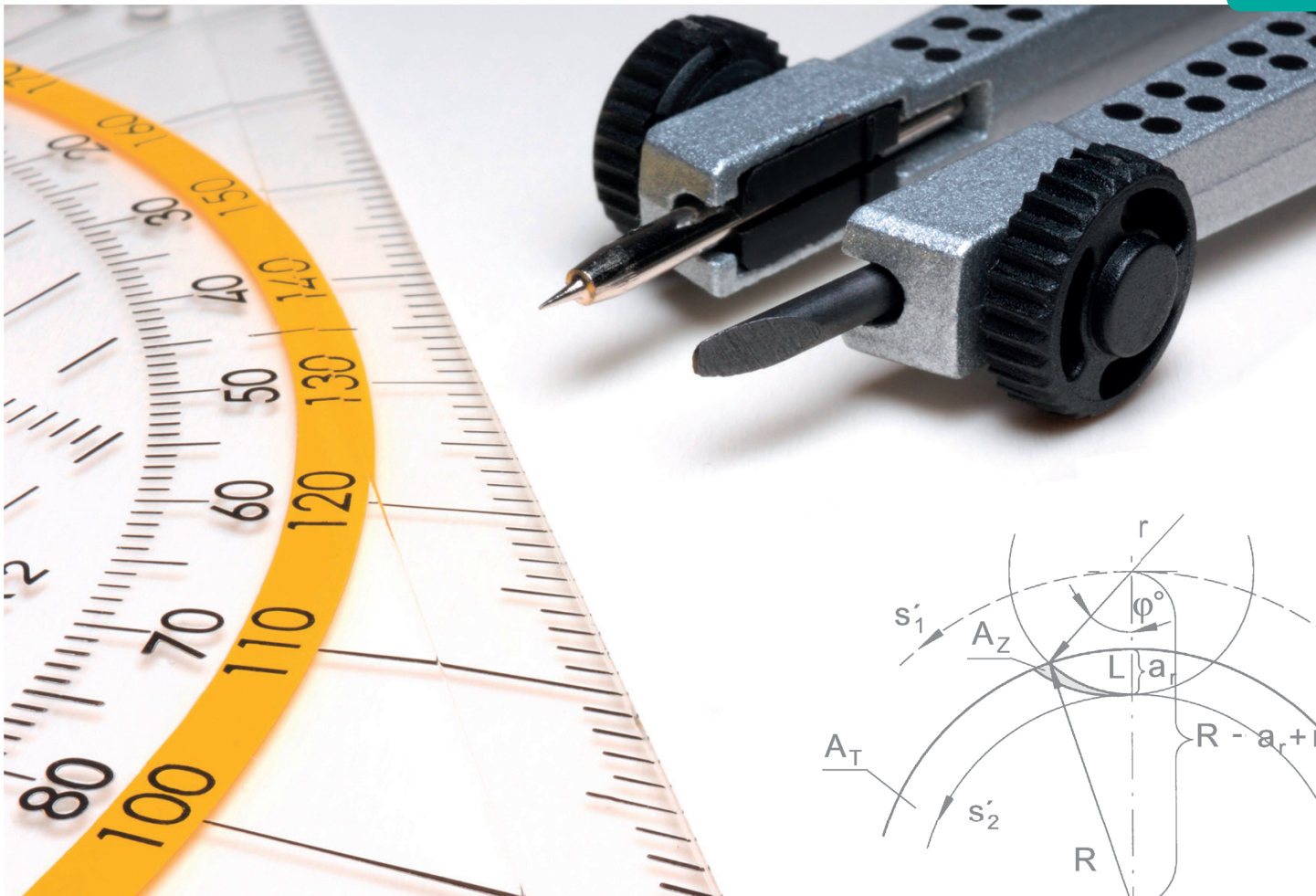

Inhalt/Summary

Seite/Page

Technische Informationen

L28-L31

Technical Information

Technische Anfrage

L32

Technical Enquiry

1. Feinstgeschliffene Spanflächen zur Vermeidung von Aufbauschneiden
2. Schartenfreie Schneidkante für beste Oberflächengüten am Werkstück
3. Innenliegende Kleinstradien von 0,02 mm für „scharfe“ Gewinde
4. Auf den Werkstoff abgestimmte Schneidengeometrie für beste Performance
5. Ganzzahlige Einstellwinkel am Wirbelapparat vereinfachen das Einstellen des Schwenkwinkels am Wirbelapparat

1. Fine ground top rake to avoid built up edge
2. Notch-free cutting edge for best surface finish on the workpiece
3. Concave small radii of 0.02 mm for „sharp“ threads
4. Special cutting geometry adapted to the material for best performance
5. Integer adjustment angles simplify the adjustment of the swivel angle on the thread whirling unit

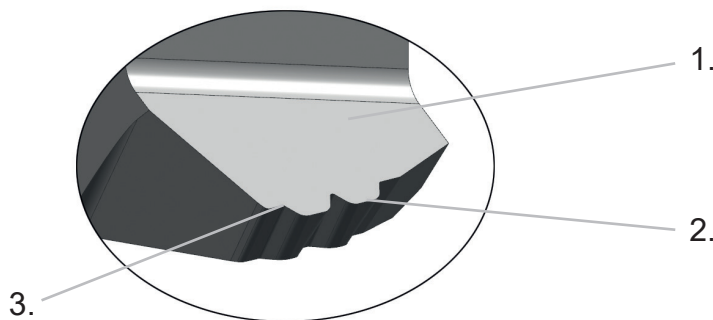

Typ / type S271 w < 6,1 mm	Typ / type S302 w < 7,5 mm Typ / type S301 w < 4,5 mm

Um beste Performance zu gewährleisten, werden die Schneidplatten individuell an die Kundenanforderung angepasst.

Die Greenline Produktionsphilosophie garantiert kürzeste Lieferzeiten.

To ensure the best performance, the inserts are individually tailored to the customer's requirements. The greenline production philosophy guarantees shortest delivery times.

Beschichtungsempfehlung / Coating Recommendation

Titan / Titanlegierungen / Titanium / Titanium alloys	AC2_ (IG3_)
Rostfreie Stähle / Stainless steels	AN2_ (IG3_)
Stahl, legiert und unlegiert / Steel, alloyed and unalloyed	EG3_
Aluminium	DD2_
Warmfeste Legierungen / Heat resistant alloys	HS3_

Schnittdaten können mit dem Schnittdatenrechner auf unserer Website unter <https://hct.phorn.de/de/Home.aspx> bestimmt werden.

Cutting data can be determined with the cutting data calculator on our website with <https://hct.phorn.de/de/Home.aspx>



Berechnung der Spitzenhöhenkorrektur der Werkzeugschneide Calculation of the centre height correction of the cutting edge

Schwenkwinkel α / Swing angle α

Der Schwenkwinkel entspricht i.d.R. dem mittleren Steigungswinkel des Gewindes. Dieser berechnet sich wie folgt.

The swing angle usually cover the medium pitch angle of thread. According following calculation:

$$\tan \alpha = \frac{P}{\pi x d}$$

Um das Einstellen des Gewindewirbelapparates zu vereinfachen, werden Horn-Gewindewirbelplatten immer auf ganzzahligen Einstellwinkel konstruiert. Der einzustellende Schwenkwinkel ist der Wendeplattenzeichnung zu entnehmen!

To simplify the adjusting of the whirling unit, at HORN we design the insert to whole pitch angle number for setup in machine.

The swivel angle to be set can be found in the insert drawing!

z.B. / e.g.

mittlerer Steigungswinkel / medium pitch angle:

7.77°

Schwenkwinkel Wirbelkopf / swing angle whirling head:

7°

ausgelegt für Schneidkreis- \emptyset / designed for cutting- \emptyset :

6 mm

Spitzenhöhenkorrektur / Centre height correction

Oftmals liegt die Schneide nicht exakt auf der Schwenkachse (Maß Δh) des Gewindewirbelapparates. Wird dieser nun in Steigungsrichtung des Gewinde eingeschwenkt liegt die Schneide nicht mehr auf Spitzenhöhe. In solchen Fällen muss daher eine Spitzenhöhenkorrektur erfolgen. Wenn „ Δh “ =0 ist, ist keine Korrektur nötig.

The cutting edge is often not exactly on the swivel axis (dimension Δh) of the thread whirling unit. If this is now swiveled in in the direction of the thread, the cutting edge is no longer at centre height. In such cases, a centre height correction must be made. If „ Δh “ = 0, no correction is necessary.

Nachstehend wird erläutert wie diese berechnet werden kann:
 The following explains how this can be calculated:

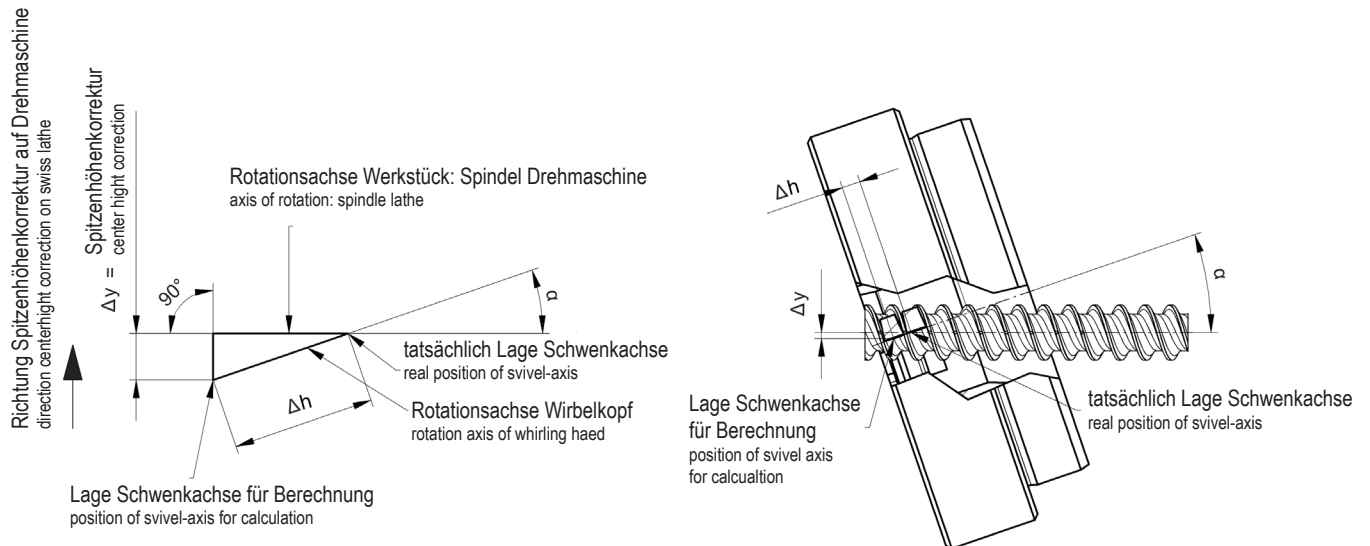

Berechnung des Korrekturwerts Δy

Calculation of the correction value Δy

$$\Delta y = \Delta h \times \sin \alpha$$

→ online <https://hct.phorn.de/>

- H** Abstand Schwenkachse Wirbelapparat zur Anlage Wirbelkopf (ist abhängig vom Gewindewirbelapparat)
Distance swivel-axis whirling unit / location face whirling head (is depending on the thread whirling unit whirling unit)
- h_2** Abstand Anlage Wirbelkopf zur Anlage Schneidplatte (diese Maß wird der Tabelle entnommen)
Distance locating face whirling head / locating face of the insert (this measure is taken from the table)
- ΔL** Abstand Schwenkmitte der Schneidplatte zur Schwenkachse des Wirbelapparats
Distance centre of form of the insert / swivel-axis of the whirling unit
- Δy** Korrekturwert Spitzenhöhe
Correction value centre height
- α** Schwenkwinkel Werkzeug
Swivel angle of the tool
- *s** Abstand Anlage Schneidplatte zum theoretischen Berechnungspunkt (diese Maß hängt von der entsprechenden Gewindewirbelplatte ab, kann der Zeichnung entnommen werden)
Distance locating face insert to the theoretical calculation point (this dimension depends on the corresponding insert which can be seen in the drawing)



Schnittposition Cutting location 		Drehrichtung Werkzeug Turning direction of whirling unit 		Drehrichtung Stange Turning direction of bar 		Schnittposition position de la coupe Cutting position 1 / 2 / 3 / 4													
				Drehrichtung Werkzeug direction de l'outil Turning direction whirling tool 5 / 6															
				Drehrichtung Stange direction de la barre turning direction of the bar 7 / 8															
Maschinenhersteller:		<i>Marque de la machine:</i>		<i>Machine manufacturer:</i>															
Maschinentyp:		<i>Type de la machine:</i>		<i>Type of machine:</i>															
Angetriebenes Werkzeug		<i>Typ/Bezeichnung</i>		<i>Marque de l'appareil à tourbillonner</i>		<i>Type of the driven tool:</i>													
Y-Achse vorhanden		<table border="1"> <tr><td><i>Ja</i></td><td><i>Nein</i></td></tr> <tr><td><i>Oui</i></td><td><i>Non</i></td></tr> <tr><td><i>Yes</i></td><td><i>No</i></td></tr> </table>		<i>Ja</i>	<i>Nein</i>	<i>Oui</i>	<i>Non</i>	<i>Yes</i>	<i>No</i>	Kühlung vorhanden		<table border="1"> <tr><td><i>Ja/Oui/Yes</i></td><td><i>Nein/Non/No</i></td></tr> <tr><td><i>Druck / pression / pressure</i></td><td></td></tr> <tr><td></td><td></td></tr> </table>		<i>Ja/Oui/Yes</i>	<i>Nein/Non/No</i>	<i>Druck / pression / pressure</i>			
<i>Ja</i>	<i>Nein</i>																		
<i>Oui</i>	<i>Non</i>																		
<i>Yes</i>	<i>No</i>																		
<i>Ja/Oui/Yes</i>	<i>Nein/Non/No</i>																		
<i>Druck / pression / pressure</i>																			
Axe y-disponible?				Lubrification disponible?															
Y-axis available?				Coolant available															
Werkstoff		<i>Matière:</i>		<i>Material:</i>		Ø <input type="text"/>													
Gewindebezeichnung		<i>Specification du filet:</i>		<i>Thread specification:</i>															
Vollprofil:		<i>Profil complet:</i>		<i>Full profile:</i>		<table border="1"> <tr><td><i>Ja</i></td><td><i>Oui</i></td><td><i>yes</i></td><td><i>Nein</i></td><td><i>non</i></td><td><i>no</i></td></tr> </table>		<i>Ja</i>	<i>Oui</i>	<i>yes</i>	<i>Nein</i>	<i>non</i>	<i>no</i>						
<i>Ja</i>	<i>Oui</i>	<i>yes</i>	<i>Nein</i>	<i>non</i>	<i>no</i>														
Konventionelles Wirbeln		<i>HORN Tourbillonnage</i>		<i>HORN Whirling</i>		<table border="1"> <tr><td><i>Ja</i></td><td><i>Oui</i></td><td><i>yes</i></td><td><i>Nein</i></td><td><i>non</i></td><td><i>no</i></td></tr> </table>		<i>Ja</i>	<i>Oui</i>	<i>yes</i>	<i>Nein</i>	<i>non</i>	<i>no</i>						
<i>Ja</i>	<i>Oui</i>	<i>yes</i>	<i>Nein</i>	<i>non</i>	<i>no</i>														
HORN Turbowirbeln®		<i>HORN Turbo Tourbillonnage</i>		<i>HORN Turbo Whirling®</i>		<table border="1"> <tr><td><i>Ja</i></td><td><i>Oui</i></td><td><i>yes</i></td><td><i>Nein</i></td><td><i>non</i></td><td><i>no</i></td></tr> </table>		<i>Ja</i>	<i>Oui</i>	<i>yes</i>	<i>Nein</i>	<i>non</i>	<i>no</i>						
<i>Ja</i>	<i>Oui</i>	<i>yes</i>	<i>Nein</i>	<i>non</i>	<i>no</i>														
Modulares System		<i>Systeme Modulaire</i>		<i>Modular System</i>		<table border="1"> <tr><td><i>Ja</i></td><td><i>Oui</i></td><td><i>yes</i></td><td><i>Nein</i></td><td><i>non</i></td><td><i>no</i></td></tr> </table>		<i>Ja</i>	<i>Oui</i>	<i>yes</i>	<i>Nein</i>	<i>non</i>	<i>no</i>						
<i>Ja</i>	<i>Oui</i>	<i>yes</i>	<i>Nein</i>	<i>non</i>	<i>no</i>														
JET-Wirbeln		<i>JET Tourbillonnage</i>		<i>JET Whirling</i>		<table border="1"> <tr><td><i>Ja</i></td><td><i>Oui</i></td><td><i>yes</i></td><td><i>Nein</i></td><td><i>non</i></td><td><i>no</i></td></tr> </table>		<i>Ja</i>	<i>Oui</i>	<i>yes</i>	<i>Nein</i>	<i>non</i>	<i>no</i>						
<i>Ja</i>	<i>Oui</i>	<i>yes</i>	<i>Nein</i>	<i>non</i>	<i>no</i>														
Standzeit aktuell		<i>Durée de vie</i>		<i>Tool life</i>		<input type="text"/>													
Aktuelles Werkzeug		<i>Outil actuelle</i>		<i>Current Tool</i>		<input type="text"/>													
Schnittdaten aktuell		<i>Conditions de coupe actuelle</i>		<i>Cutting speed actual</i>		<input type="text"/>													
Drehzahl Wirbelring		<i>Vitesse tourbillonneur</i>		<i>Rpm Cutter</i>		<input type="text"/> 1/min													
Drehzahl Spindel		<i>Vitesse broche</i>		<i>Rpm Spindle</i>		<input type="text"/> 1/min													
Programmierter C-Achsenvorschub in °		<i>Programmation axe C en °</i>		<i>Feed C axe in °</i>		<input type="text"/> °/min													
Zielsetzung		<i>Objectif</i>		<i>Target</i>		Skizze													
						<i>Croquis</i>													
						<i>Sketch</i>													

Datum _____

Name _____

Unterschrift _____



Passende Wirbelapparate finden Sie im Katalog „MODULARE LANGDREHTECHNIK“.

Suitable whirling units can be found in the catalogue „MODULAR TECHNOLOGY FOR SWISS TYPE MACHINES“.



L

