



SWISS  TOOLS®

S w i s s
M B M
20/10

by **SWISS  TOOLS**

Seite / page 17

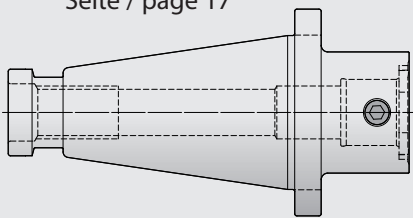

Seite / page 15+16

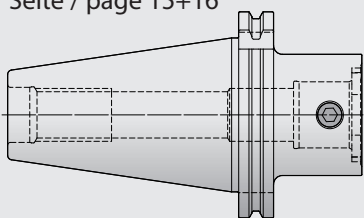

Seite / page 17

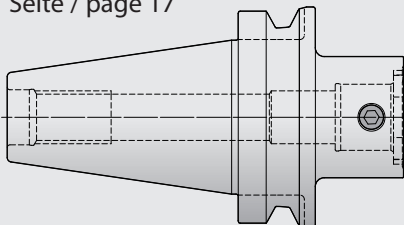

Seite / page 15

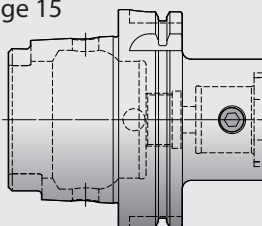

Seite / page 16

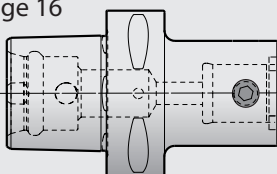

Seite / page 52

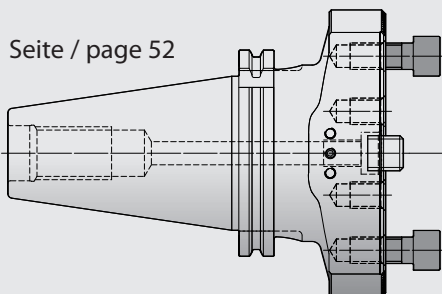

Seite / page 52

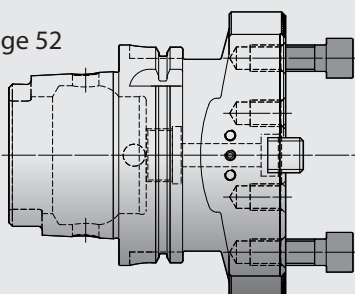

Seite / page 19

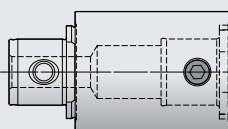

Seite / page 18

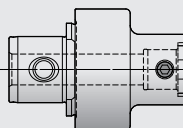

Seite / page 52

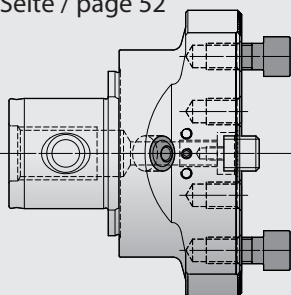

Seite / page 49

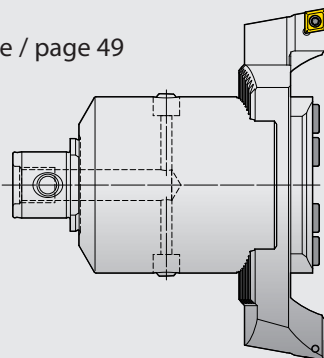

Seite / page 40-42

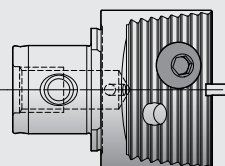

Seite / page 53

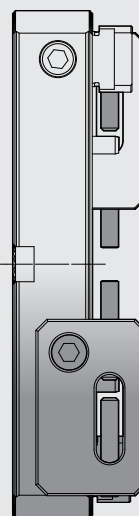

Seite / page 54

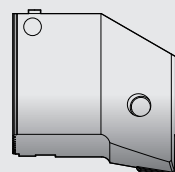
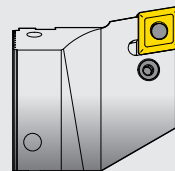

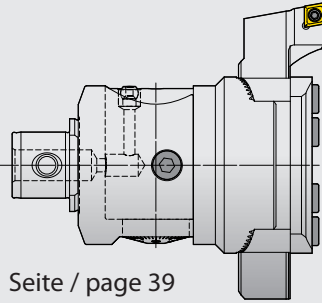

Seite / page 39

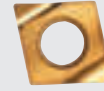

Wendeplatten / Inserts
Seite / page 60 / 62+63

Seite / page 38

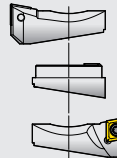

Seite / page 6

Seite / page 37



NEW
DIGITAL

NEW
DIGITAL

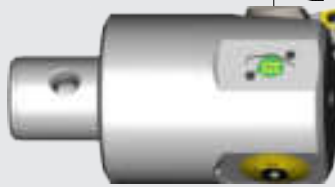

Seite / page 42-43

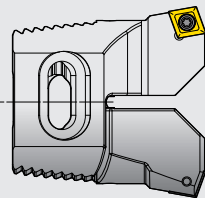

Seite / page 25

Seite / page 32-36

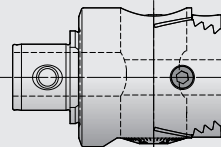

NEW

Seite / page 29

Seite /
page 30



Seite / page 25

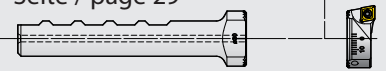

Seite / page 28

Seite / page 55

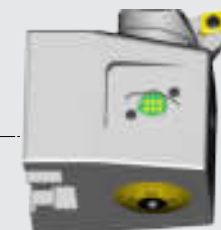

NEW
DIGITAL

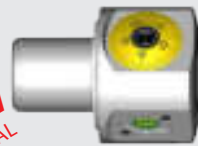

Seite / page 27

Seite / page 26

Seite / page 22

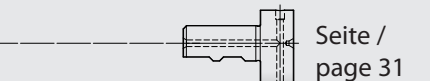

Seite /
page 31



Seite / page 26

Seite / page 20

Seite / page 57

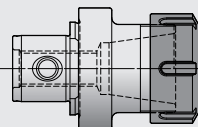

Seite / page 58

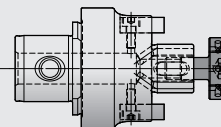

Seite / page 56

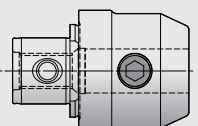

Seite / page 59

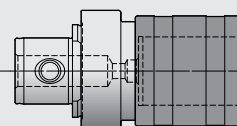

Seite / page 60+61

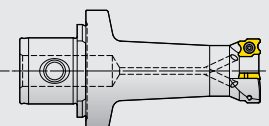

• Technische Hinweise siehe Betriebsan-
leitung

• For more technical information see
operating manual

THE WORLD'S SMALLEST

digital fine boring head from \varnothing 0.3 mm



WELTNEUHEIT

kleinster digitaler Feinbohrkopf ab \varnothing 0.3 mm

SWISS DAMPING TECHNOLOGY

schwingungsgedämpfte Lösungen
damped boring solutions



PSC DIGITALE FEINBOHRWERKZEUGE DIGITAL FINE BORING HEADS

- ein Display für alle Feinbohrköpfe
Ø 0.3 mm - 2205.0 mm
 - Anzeige umkehrbar (Links-/ Rechtshänder)
 - mm/inch umschaltbar
 - Standard AAA Batterie zur Stromversorgung
 - Display wird über Magnetkraft am Werkzeug gehalten
 - Einstellgenauigkeit 0.001mm im Durchmesser
 - direktes Wegmeßsystem (kein Umkehrspiel)
 - keine Batterie und Auswerteelektronik im Werkzeug verbaut
 - sehr einfache Bedienung
 - digital und analog einsetzbar
- one display for all fine boring heads diameter 0.3 mm – 2205 mm
 - display reversible (LH/RH)
 - mm/inch switchable
 - standard AAA battery required
 - display unit will docked with magnetic forces at the tool
 - 0.001 accuracy in diameter
 - direct measurement system (no backlash)
 - no battery and electronic evaluation unit inside the tool
 - very easy operation
 - for digital and analog use



ECO LINE

MODULAR BORING SYSTEM Ø 9.75 - 650.1 mm
don't think about the interface you already have it

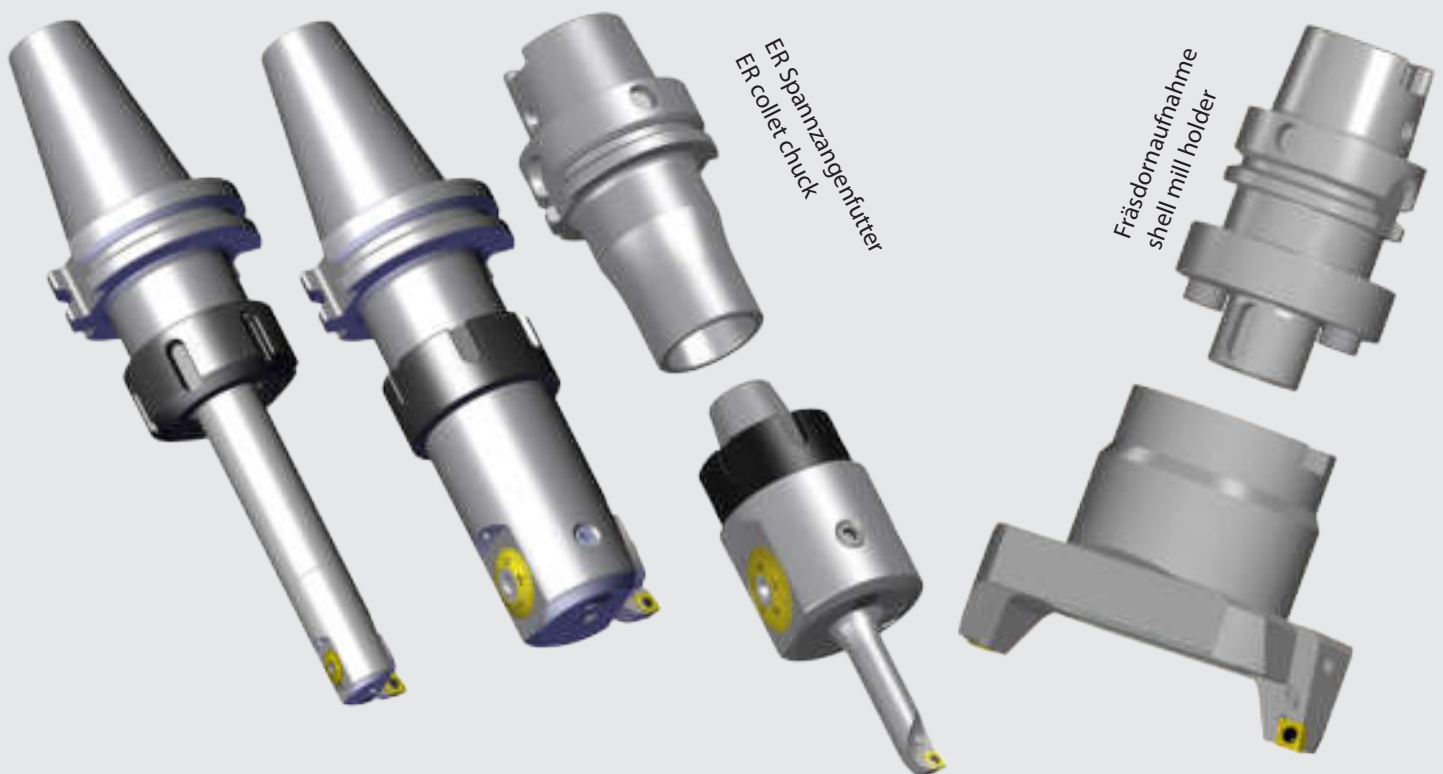

**DIGITALE
Anzeigeeinheit**

**DIGITAL
display unit**

NEW

- ein Display für alle Feinbohrköpfe Ø 0.3 mm - 2205.0 mm
 - Anzeige umkehrbar (Links-/ Rechtshänder)
 - mm/inch umschaltbar
 - Standard AAA Batterie zur Stromversorgung
 - Display wird über Magnetkraft am Werkzeug gehalten
 - Einstellgenauigkeit 0.001mm im Durchmesser
 - direktes Wegmeßsystem (kein Umkehrspiel)
 - keine Batterie und Auswerteelektronik im Werkzeug verbaut
 - sehr einfache Bedienung
 - digital und analog einsetzbar
- one display for all fine boring heads diameter 0.3 mm – 2205 mm
 - display reversible (LH/RH)
 - mm/inch switchable
 - standard AAA battery required
 - display unit will docked with magnetic forces at the tool
 - 0.001 accuracy in diameter
 - direct measurement system (no backlash)
 - no battery and electronic evaluation unit inside the tool
 - very easy operation
 - for digital and analog use



Bestell-Nr. / Order number	Anzeigeeinheit/ display unit
266.028.077	

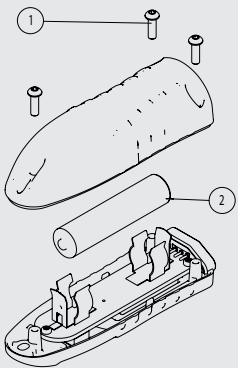

Ersatzteile / Zubehör

Spare parts / Accessories

266

Für Anzeigeeinheit For display unit	Bestell-Nr. / Order number	Bestell-Nr. / Order number	Bestell-Nr. / Order number
	Torx-Schraube / Torx screw ①	Batterie / Battery ②	Torx-Schlüssel / Torx driver
266.028.077	879.028.077	879.011.045	842.005.000



Ø 150.0 mm - 2205.0 mm



Ø 3.0 mm - 88.1 mm



Ø 23.9 mm - 203.1 mm

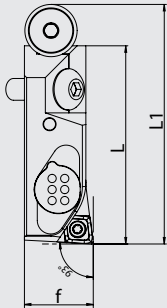
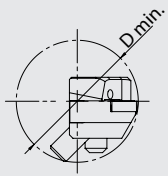

- Einfaches Handling
- Präzise Masskorrektur
- Direktes Weg-Messsystem
- Wartungsfrei

- Easy handling
- Precise adjustment
- No backlash
- Maintenance-free

Bestell-Nr. / Order number	f	Ø D min.	L	L	Wendeplatte / Insert
KKH.WCA.016.045	16	25	45	55	CC.. 06 02 ..

- Feinverstellung digitale Anzeige 0.001mm
- Radialer Verstellweg: min. 0,4 mm
- Axiale Längenverstellung: 1.5 mm über Keilelement
- Drehzahl: max.10.000 U/min
- Innenkühlung direkt auf die Werkzeug-schneide

- Fine adjustment digital display 0.001mm
- Radial adjustment: min. 0.4 mm
- Axial length adjustment: 1.5 mm
- Speed: max.10.000 rpm
- Internal cooling directly on the tool cutting edge

NEW



Bestell-Nr. / Order number	Anzeigeeinheit/ display unit
GH1.DA2.BGK.077	

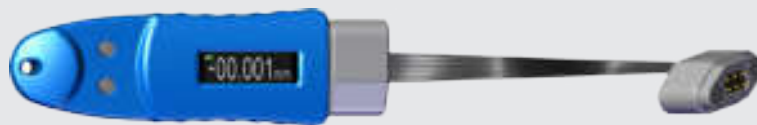

- Anzeige umkehrbar (Links-/ Rechtshänder)
- mm/inch umschaltbar
- Standard AAA Batterie zur Stromversorgung
- Display wird über Magnetkraft am Werkzeug gehalten
- Einstellgenauigkeit 0.001mm im Durchmesser
- direktes Wegmeßsystem (kein Umkehrspiel)
- keine Batterie und Auswerteelektronik im Werkzeug verbaut
- sehr einfache Bedienung
- digital und analog einsetzbar

- display reversible (LH/RH)
- mm/inch switchable
- standard AAA battery required
- display unit will docked with magnetic forces at the tool
- 0.001 accuracy in diameter
- direct measurement system (no backlash)
- no battery and electronic evaluation unit inside the tool
- very easy operation
- for digital and analog use

• erweiterbar von $\varnothing 3$ bis $\varnothing 88.1$ • can be upgraded from $\varnothing 3$ up to $\varnothing 88.1$ 

Bestell-Nr. / Order number	D	$\varnothing A$ min.	$\varnothing A$ max.	L	L1	Ausdrehkopf / Fine boring head
MBM 55 modular						
528.000.030	55	9.75	30.1	45	75	262.550.045
DIN 69893 HSK 63 A						
528.063.030	55	9.75	30.1	95	70	269.063.095
DIN 69871 AD 40						
528.415.030	55	9.75	30.1	90	80	269.415.090
MAS BT 40						
528.412.030	55	9.75	30.1	90	80	269.412.090

Inhalt**Content**

1 Koffer / Case

1 Ausdrehkopf / Fine boring head

1 Ausdrehstahl / Boring bar $\varnothing 9.75-15.1$ 272.010.0061 Ausdrehstahl / Boring bar $\varnothing 14.75-20.1$ 272.015.0061 Ausdrehstahl / Boring bar $\varnothing 19.75-25.1$ 272.020.0061 Ausdrehstahl / Boring bar $\varnothing 24.75-30.1$ 272.025.006

1 Inbusschlüssel / Allen wrench SW5

1 Torx-Schlüssel / Torx driver T7

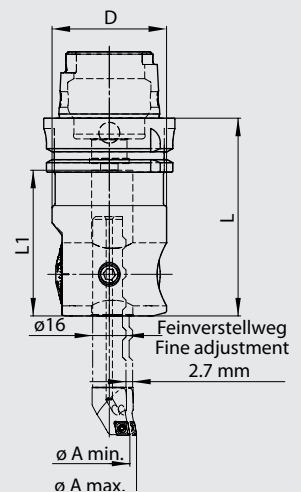
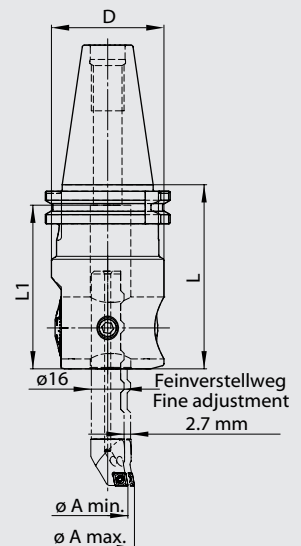
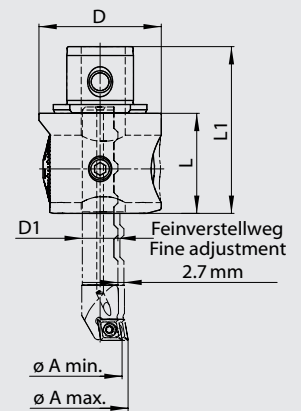
• erweiterbar von $\varnothing 3$ bis $\varnothing 88.1$ • can be upgraded from $\varnothing 3$ up to $\varnothing 88.1$ 

Bestell-Nr. / Order number	D	$\varnothing A$ min.	$\varnothing A$ max.	L	L1	Ausdrehkopf / Fine boring head
MBM 55 modular						
521.000.030	55	9.75	30.1	45	75	266.550.045
DIN 69893 HSK 63 A						
521.063.030	55	9.75	30.1	95	70	266.063.095
DIN 69871 AD 40						
521.415.030	55	9.75	30.1	90	80	266.415.090
MAS BT 40						
521.412.030	55	9.75	30.1	90	80	266.412.090

Inhalt**Content**

1 Koffer / Case

1 Ausdrehkopf / Fine boring head

1 Ausdrehstahl / Boring bar $\varnothing 9.75-15.1$ 272.010.0061 Ausdrehstahl / Boring bar $\varnothing 14.75-20.1$ 272.015.0061 Ausdrehstahl / Boring bar $\varnothing 19.75-25.1$ 272.020.0061 Ausdrehstahl / Boring bar $\varnothing 24.75-30.1$ 272.025.006

1 Inbusschlüssel / Allen wrench SW5

1 Torx-Schlüssel / Torx driver T7

1 Digitale Anzeigeeinheit / dig. display 266.028.077

• erweiterbar von $\varnothing 3$ bis $\varnothing 88.1$

• can be upgraded from $\varnothing 3$ up to $\varnothing 88.1$

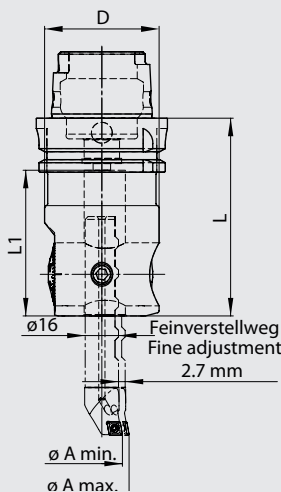
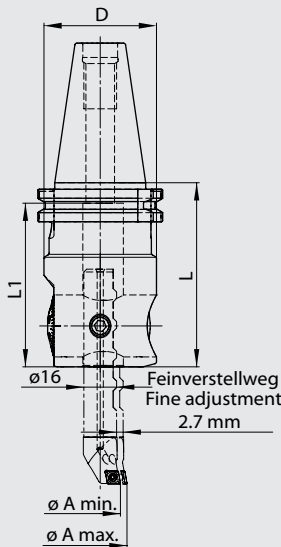
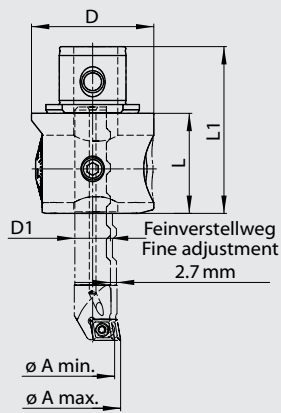

Bestell-Nr. / Order number	D	$\varnothing A$ min.	$\varnothing A$ max.	L	L1	Ausdrehkopf / Fine boring head
MBM 55 modular						
527.000.088	55	9.75	88.1	45	75	262.550.045
DIN 69893 HSK 63 A						
527.063.088	55	9.75	88.1	95	70	269.063.095
DIN 69871 AD 40						
527.415.088	55	9.75	88.1	90	80	269.415.090
MAS BT 40						
527.412.088	55	9.75	88.1	90	80	269.412.090

Inhalt	Content
1 Koffer / Case	
1 Ausdrehkopf / Fine boring head	
1 Ausdrehstahl / Boring bar	$\varnothing 9.75-15.1$ 272.010.006
1 Ausdrehstahl / Boring bar	$\varnothing 14.75-20.1$ 272.015.006
1 Ausdrehstahl / Boring bar	$\varnothing 19.75-25.1$ 272.020.006
1 Ausdrehstahl / Boring bar	$\varnothing 24.75-30.1$ 272.025.006
1 Schaft / shank	$\varnothing 29.75-48.1$ 271.030.048
1 Schaft / shank	$\varnothing 47.75-88.1$ 271.048.088
1 Wendeplattenhalter / Insert holder	$\varnothing 29.75-48.1$ 253.030.006
1 Wendeplattenhalter / Insert holder	$\varnothing 47.75-88.1$ 253.048.006
1 Inbusschlüssel / Allen wrench	SW4
1 Inbusschlüssel / Allen wrench	SW5
1 Torx-Schlüssel / Torx driver	T7



**Ausdrehset $\varnothing 9.75-88.1$
DIGITAL**

**Fine boring set $\varnothing 9.75-88.1$
DIGITAL**

• erweiterbar von $\varnothing 3$ bis $\varnothing 88.1$

• can be upgraded from $\varnothing 3$ up to $\varnothing 88.1$

Bestell-Nr. / Order number	D	$\varnothing A$ min.	$\varnothing A$ max.	L	L1	Ausdrehkopf / Fine boring head
MBM 55 modular						
521.000.088	55	9.75	88.1	45	75	266.550.045
DIN 69893 HSK 63 A						
521.063.088	55	9.75	88.1	95	70	266.063.095
DIN 69871 AD 40						
521.415.088	55	9.75	88.1	90	80	266.415.090
MAS BT 40						
521.412.088	55	9.75	88.1	90	80	266.412.090

Inhalt	Content
1 Koffer / Case	
1 Ausdrehkopf / Fine boring head	
1 Ausdrehstahl / Boring bar	$\varnothing 9.75-15.1$ 272.010.006
1 Ausdrehstahl / Boring bar	$\varnothing 14.75-20.1$ 272.015.006
1 Ausdrehstahl / Boring bar	$\varnothing 19.75-25.1$ 272.020.006
1 Ausdrehstahl / Boring bar	$\varnothing 24.75-30.1$ 272.025.006
1 Schaft / shank	$\varnothing 29.75-48.1$ 271.030.048
1 Schaft / shank	$\varnothing 47.75-88.1$ 271.048.088
1 Wendeplattenhalter / Insert holder	$\varnothing 29.75-48.1$ 253.030.006
1 Wendeplattenhalter / Insert holder	$\varnothing 47.75-88.1$ 253.048.006
1 Inbusschlüssel / Allen wrench	SW4
1 Inbusschlüssel / Allen wrench	SW5
1 Torx-Schlüssel / Torx driver	T7
1 Digitale Anzeigeeinheit / dig. display	266.028.077

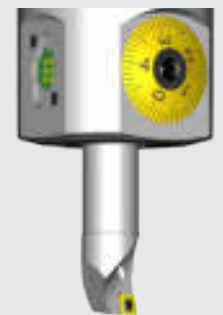

Ausdrehset $\varnothing 9.75-164$ Fine boring set $\varnothing 9.75-164$ • erweiterbar von $\varnothing 3$ bis $\varnothing 320$ • can be upgraded from $\varnothing 3$ up to $\varnothing 320$ 

Bestell-Nr. / Order number	D1	$\varnothing A / \varnothing A1$ min.-max.	L	L1	L2	Ausdrehkopf / Fine boring head
MBM 55 modular						
530.000.164	63	9.75-164	66	96	95	261.550.065
DIN 69893 HSK 63 A						
530.063.164	63	9.75-164	96	72.5	125	261.063.095
DIN 69871 AD 40						
530.415.164	63	9.75-164	91	81	120	261.415.090
MAS BT 40						
530.412.164	63	9.75-164	91	81	120	261.412.090

Inhalt	Content	
1 Koffer / Case		
1 Ausdrehkopf / Fine boring head		
1 Ausdrehstahl / Boring bar	$\varnothing 9.75-15.1$	272.010.006
1 Ausdrehstahl / Boring bar	$\varnothing 14.75-20.1$	272.015.006
1 Ausdrehstahl / Boring bar	$\varnothing 19.75-25.1$	272.020.006
1 Ausdrehstahl / Boring bar	$\varnothing 24.75-30.1$	272.025.006
1 Schaft / shank	$\varnothing 29.75-48.1$	271.030.048
1 Schaft / shank	$\varnothing 47.75-88.1$	271.048.088
1 Brücke / Bridge	$\varnothing 80$	886.086.164
1 Wendeplattenhalter / Insert holder	$\varnothing 29.75-48.1$	253.030.006
1 Wendeplattenhalter / Insert holder	$\varnothing 47.75-88.1$	253.048.006
1 Inbusschlüssel / Allen wrench	SW4	
1 Inbusschlüssel / Allen wrench	SW5	
1 Torx-Schlüssel / Torx driver	T7	

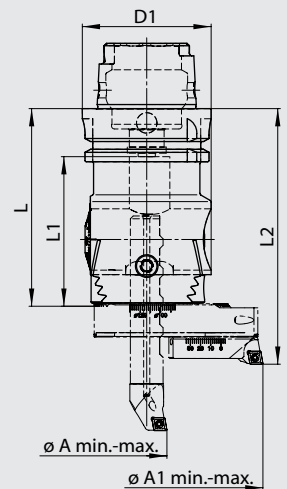
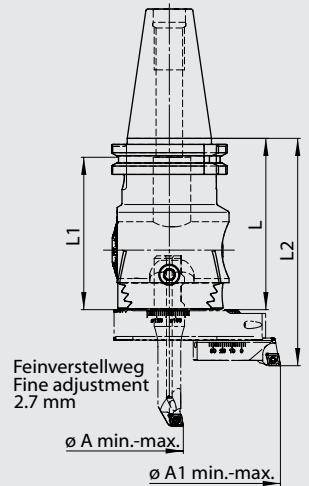
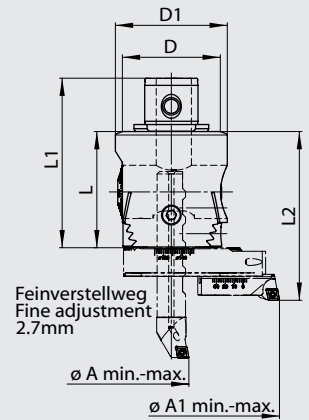

Ausdrehset ø9.75-101.1

Fine boring set ø9.75-101.1

- Zustellgenauigkeit 0.01mm resp. über Nonius 0.002mm im Durchmesser
- erweiterbar von ø3 bis ø152.1
- 0.01mm diametrical adjustment resp. 0.002mm by nonius
- can be upgraded from ø3 up to ø152.1

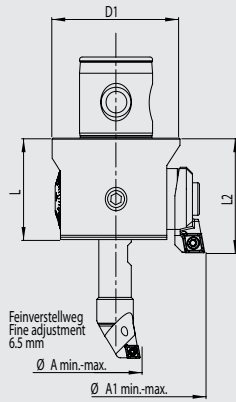

Bestell-Nr. / Order number	D1	L	L2	ø A min.	ø A max.	Ausdrehkopf / Fine boring head
525.550.101	63	50.5	57	9.75	101.1	267.550.152

Inhalt	Content
1 Koffer / Case	
1 Ausdrehkopf / Fine boring head	MBM 55 267.550.152
1 Ausdrehstahl / Boring Bar	ø 9.75 - 20.1 272.010.006
1 Ausdrehstahl / Boring Bar	ø 19.75 - 30.1 272.020.006
1 Schaft / Shank	ø 29.75 - 48.1 271.030.048
1 Schaft / Shank	ø 47.75 - 88.1 271.048.088
1 Wendeplattenhalter / Insert holder	ø 29.75 - 48.1 253.030.006
1 Wendeplattenhalter / Insert holder	ø 47.75 - 88.1 253.048.006
1 Wendeplattenhalter / Insert holder CC . . 09 T3 . .	ø 87.75 - 101.1 (Ø114.1) 254.261.009
1 Kühlmittleinsatz / Coolant plug	918.000.032
2 Torx-Schlüssel / Torx driver	T7 / T15 842.006.000 842.009.000
4 Inbusschlüsselset / Allen wrench set	SW 2.5/4/5/8

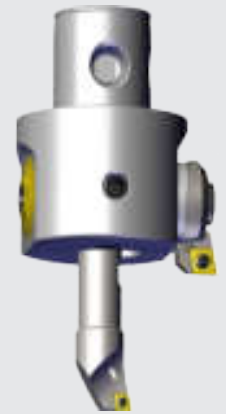

Zubehör	Accessories
Wendeplattenhalter / Insert holder CC . . 09 T3 . .	ø 105.75 - 119.0 (ø 132.0) 254.262.009
Wendeplattenhalter / Insert holder CC . . 09 T3 . .	ø 125.75 - 139.0 (ø 152.0) 254.263.009
Distanzstück / Adapter F = 6.5 mm	ø 114.0 / ø 132.0 / ø 152.0 889.000.006

551

Ausdrehset ø86-302

Fine boring set ø86-302

- erweiterbar bis ø402
- can be upgraded up to ø402

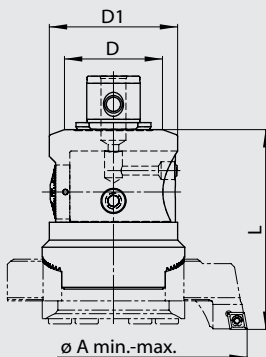

Bestell-Nr. / Order number	D	D1	ø A min.	ø A max.	L	Feinbohrkopf / Fine boring head
MBM 55 modular						
551.000.302	55	72	86	302	112	256.550.000

Inhalt	Content
1 Koffer / Case	
1 Feinbohrkopf / Fine boring head	256.550.000
1 Wendeplattenhalter / Insert holder	ø86-138 190.550.109
1 Wendeplattenhalter / Insert holder	ø136-220 190.550.209
1 Wendeplattenhalter / Insert holder	ø188-302 190.550.309
1 Abstützung / Support block	885.190.109
1 Abstützung / Support block	885.190.209
1 Druckplatte / Clamp plate	884.190.109
1 Druckplatte / Clamp plate	884.190.209
10 Wendeplatten / Inserts	CC . . 09 T3 . . 600.200.094
1 Inbusschlüssel / Allen wrench	SW5
1 Torx-Schlüssel / Torx driver	T15



Ausdrehkopf ø39.9-70.1

Fine boring head ø39.9-70.1

- Schnittstelle ER25 DIN6499
- Zustellgenauigkeit 0.01mm im Durchmesser
- für Wendeplatten CC . . 06 02 . .
- erweiterbar bis ø100.1

- connection ER25 DIN 6499
- 0.01mm diametrical adjustment
- for inserts CC . . 06 02 . .
- can be upgraded to ø100.1

ECO LINE



Bestell-Nr. / Order number	D	L	L1	L2	ø A min.	ø A max.	Ausdrehkopf / Fine boring head
526.001.070	39	25.5	8	20.5	39.9	70.1	267.040.070

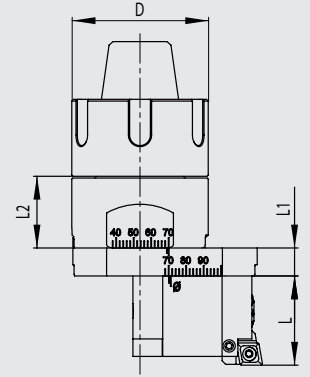

Inhalt	Content	
1 Grundkörper / Base unit	ER25	216.025.000
1 Feinbohrkopf / Fine boring head	ø 39.9 - 70.1	267.040.070
4 Schraube / Screw	M4 x 25	858.216.025
1 Torxschlüssel / Torx wrench	T7	842.006.000
2 Inbusschlüsselset / Allen key set	SW 2.5 / 3	

Zubehör	Accessories	
Erweiterung / Extension	ø 69.9 - 100.1	889.070.100

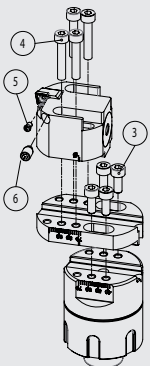

Für Feinbohrkopf	Bestell-Nr. / Order number	Bestell-Nr. / Order number	Bestell-Nr. / Order number	Bestell-Nr. / Order number
For fine boring head	Schraube / Screw	Schraube / Screw	Torx-Schraube / Torx-Screw	Klemmschraube / Clamping screw
267.040.070	858.216.010 (3)	858.216.025 (4)	843.006.000 (5)	881.216.008 (6)

Ausdrehset Ø9.75-101.1

Fine boring set Ø9.75-101.1

525

- Schnittstelle ER40 DIN6499
- Zustellgenauigkeit 0.01mm resp. über Nonius 0.002mm im Durchmesser
- erweiterbar von Ø3 bis Ø152.1

- connection ER40 DIN 6499
- 0.01mm diametrical adjustment resp. 0.002mm by nonius
- can be upgraded from Ø3 up to Ø152.1

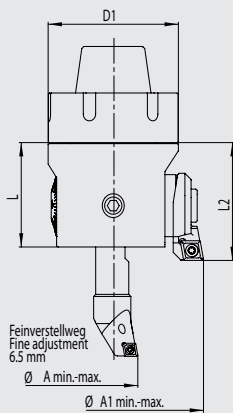

Bestell-Nr. / Order number	D1	L	L2	Ø A min.	Ø A max.	Ausdrehkopf / Fine boring head
525.001.101	63	50.5	57	9.75	101.1	267.003.152

Inhalt	Content
1 Koffer / Case	
1 Ausdrehkopf / Fine boring head	ER40 267.003.152
1 Ausdrehstahl / Boring Bar	Ø 9.75 - 20.1 272.010.006
1 Ausdrehstahl / Boring Bar	Ø 19.75 - 30.1 272.020.006
1 Schaft / Shank	Ø 29.75 - 48.1 271.030.048
1 Schaft / Shank	Ø 47.75 - 88.1 271.048.088
1 Wendeplattenhalter / Insert holder	Ø 29.75 - 48.1 253.030.006
1 Wendeplattenhalter / Insert holder	Ø 47.75 - 88.1 253.048.006
1 Wendeplattenhalter / Insert holder CC . . 09 T3 . .	Ø 87.75 - 101.1 (Ø114.1) 254.261.009
1 Kühlmitteleinsatz / Coolant plug	918.000.032
2 Torx-Schlüssel / Torx driver	T7 / T15 842.006.000 842.009.000
4 Inbusschlüsselset / Allen wrench set	SW 2.5/4/5/8



Zubehör	Accessories
Wendeplattenhalter / Insert holder CC . . 09 T3 . .	Ø 105.75 - 119.0 (Ø 132.0) 254.262.009
Wendeplattenhalter / Insert holder CC . . 09 T3 . .	Ø 125.75 - 139.0 (Ø 152.0) 254.263.009
Distanzstück / Adapter F = 6.5 mm	Ø 114.0 / Ø 132.0 / Ø 152.0 889.000.006

SMART-
HEAD

Ausdrehset Ø9.75-30.1

Fine boring set Ø9.75-30.1

528

- erweiterbar von Ø3 bis Ø88.1
- Schnittstelle ER32 DIN6499

- can be upgraded from Ø3 up to Ø88.1
- connection ER32 DIN 6499

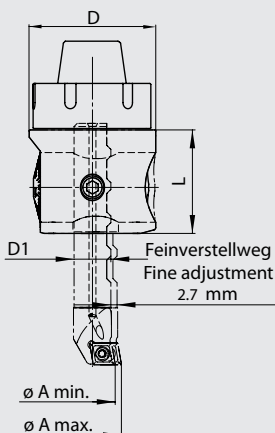

Bestell-Nr. / Order number	D	Ø A min.	Ø A max.	L	Ausdrehkopf / Fine boring head
SMART ER32					
528.032.030	55	9.75	30.1	60	262.032.060

Inhalt	Content
1 Koffer / Case	
1 Ausdrehkopf / Fine boring head	262.032.060
1 Ausdrehstahl / Boring bar	Ø9.75-15.1 272.010.006
1 Ausdrehstahl / Boring bar	Ø14.75-20.1 272.015.006
1 Ausdrehstahl / Boring bar	Ø19.75-25.1 272.020.006
1 Ausdrehstahl / Boring bar	Ø24.75-30.1 272.025.006
1 Inbusschlüssel / Allen wrench	SW5
1 Torx-Schlüssel / Torx driver	T7



Grosse Steifigkeit dank hoher Vorspannkraften und grosser Auflageflächen. Höchste Drehmomentübertragung ohne Beeinträchtigung der Austauschbarkeit. Bohrung für Kühlmitteldurchgang.

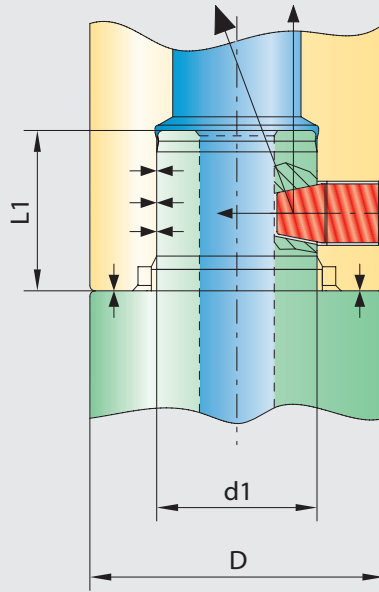

Maximum rigidity due to high preloading forces and large bearing surfaces. Maximum torque transmission without loss of interchangeability or ease of maintenance. Bored for spindle coolant supply.

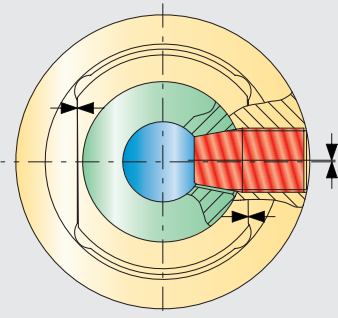

Symmetrisch angeordnete Mitnahmeflächen gewährleisten die konzentrische Übertragung von hohen Drehmomenten.

Symmetrical distribution of the torque forces through uniformly arranged driving surfaces.

Vibrationsarm, da das ohnehin kleine Passungsspiel mit dem Spannen der Verbindung aufgehoben wird.

Minimal operating vibrations since the small fitting play is eliminated through the locking forces.

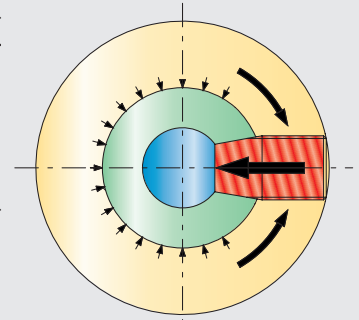

Dimensionen

Dimensions

System ø D	d1	L	M	SW / AF	Anzugsdrehmoment / Torque
20	11	11	M5x0.5	2.5	2.5Nm
25	14	14	M6x0.75	3	4.5Nm
32	18	18	M8x1	4	10Nm
42	24	24	M12x1	6	25Nm
55	30	30	M12x1	6	30Nm
72	40	40	M16x1.5	8	40Nm
94	50	50	M20x1.5	10	60Nm

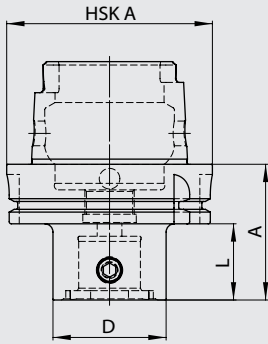

Bestell-Nr. / Order number	HSK A	System ø D	L	A
102.032.251	32	25	15	35
102.032.321	32	32	30	50
102.040.421	40	42	35	55
102.050.551	50	55	40	66
102.063.201	63	20	24	50
102.063.251	63	25	24	50
102.063.321	63	32	24	50
102.063.421	63	42	24	50
102.063.551	63	55	40	66
102.063.552	63	55	74	100
102.063.721	63	72	50	76
102.063.941	63	94	79	105
102.080.321	80	32	25	51
102.080.421	80	42	30	56
102.080.551	80	55	40	66
102.080.721	80	72	50	76
102.080.941	80	94	56	82
102.100.321	100	32	22	51
102.100.421	100	42	27	56
102.100.551	100	55	37	66
102.100.721	100	72	47	76
102.100.941	100	94	57	86

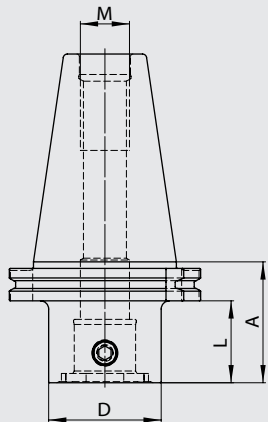

Bestell-Nr. / Order number	ISO	System ø D	L	A	M
102.315.201	30	20	20	39.1	M12
102.315.251	30	25	20	39.1	M12
102.315.321	30	32	20	39.1	M12
102.315.421	30	42	20	39.1	M12
102.315.551	30	55	20	39.1*	M12
102.415.201	40	20	15	34.1	M16
102.415.202	40	20	40	59.1	M16
102.415.251	40	25	25	44.1	M16
102.415.252	40	25	55	74.1	M16
102.415.321	40	32	25	44.1	M16
102.415.322	40	32	65	84.1	M16
102.415.421	40	42	30	49.1	M16
102.415.422	40	42	80	99.1	M16
102.415.551	40	55	40	59.1	M16
102.415.552	40	55	100	119.1	M16
102.415.721	40	72	60	79.1	M16
102.415.941	40	94	60	79.1*	M16
102.515.201	50	20	15	34.1	M24
102.515.202	50	20	40	59.1	M24
102.515.251	50	25	25	44.1	M24
102.515.252	50	25	55	74.1	M24
102.515.321	50	32	25	44.1	M24
102.515.322	50	32	65	84.1	M24
102.515.421	50	42	30	49.1	M24
102.515.422	50	42	80	99.1	M24
102.515.551	50	55	40	59.1	M24
102.515.552	50	55	100	119.1	M24
102.515.721	50	72	60	79.1	M24
102.515.722	50	72	120	139.1	M24
102.515.941	50	94	60	79.1	M24
102.515.942	50	94	150	169.1	M24



* Entspricht nicht DIN 69871, keine Freistellung nach dem Bund

* Not according to DIN 69871, without groove

• Kühlmittelzufuhr über den Bund

• coolant supply through the tool flange



Bestell-Nr. / Order number	ISO	System ø D	L	A	M
102.325.201	30	20	20	39.1	M12
102.325.251	30	25	20	39.1	M12
102.325.321	30	32	20	39.1	M12
102.325.421	30	42	20	39.1	M12
102.325.551	30	55	20	39.1*	M12
102.425.201	40	20	15	34.1	M16
102.425.202	40	20	40	59.1	M16
102.425.251	40	25	25	44.1	M16
102.425.252	40	25	55	74.1	M16
102.425.321	40	32	25	44.1	M16
102.425.322	40	32	65	84.1	M16
102.425.421	40	42	30	49.1	M16
102.425.422	40	42	80	99.1	M16
102.425.551	40	55	40	59.1	M16
102.425.552	40	55	100	119.1	M16
102.425.721	40	72	60	79.1	M16
102.425.941	40	94	60	79.1*	M16
102.525.201	50	20	15	34.1	M24
102.525.202	50	20	40	59.1	M24
102.525.251	50	25	25	44.1	M24
102.525.252	50	25	55	74.1	M24
102.525.321	50	32	25	44.1	M24
102.525.322	50	32	65	84.1	M24
102.525.421	50	42	30	49.1	M24
102.525.422	50	42	80	99.1	M24
102.525.551	50	55	40	59.1	M24
102.525.552	50	55	100	119.1	M24
102.525.721	50	72	60	79.1	M24
102.525.722	50	72	120	139.1	M24
102.525.941	50	94	60	79.1	M24
102.525.942	50	94	150	169.1	M24

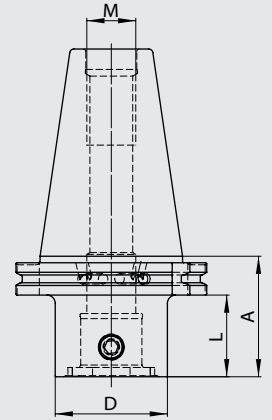

* Entspricht nicht DIN 69871, keine Freistellung nach dem Bund

* Not according to DIN 69871, without groove



Bestell-Nr. / Order number	PSC	System ø D	L	A
102.163.201	63	20	28	50
102.163.251	63	25	28	50
102.163.321	63	32	28	50
102.163.421	63	42	28	50
102.163.551	63	55	38	60
102.163.721	63	72	36	60
102.163.941	63	94	66	90

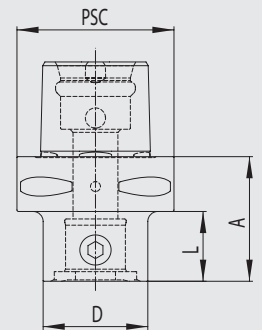

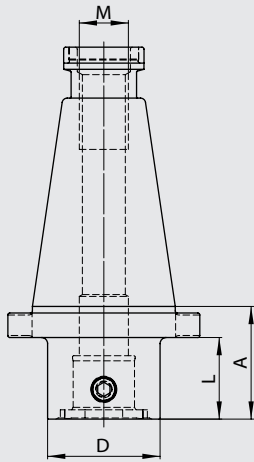

Bestell-Nr. / Order number	ISO	System ø D	L	A	M
102.400.201	40	20	15	26.6	M16
102.400.202	40	20	40	51.6	M16
102.400.251	40	25	25	36.6	M16
102.400.252	40	25	55	66.6	M16
102.400.321	40	32	25	36.6	M16
102.400.322	40	32	65	76.6	M16
102.400.421	40	42	30	41.6	M16
102.400.422	40	42	80	91.6	M16
102.400.551	40	55	40	51.6	M16
102.400.552	40	55	100	111.6	M16
102.400.721	40	72	60	71.6	M16
102.400.722	40	72	120	131.6	M16
102.500.201	50	20	15	30.2	M24
102.500.202	50	20	40	55.2	M24
102.500.251	50	25	25	40.2	M24
102.500.321	50	32	25	40.2	M24
102.500.421	50	42	30	45.2	M24
102.500.422	50	42	80	95.2	M24
102.500.551	50	55	40	55.2	M24
102.500.552	50	55	100	115.2	M24
102.500.721	50	72	60	75.2	M24
102.500.722	50	72	120	135.2	M24
102.500.942	50	94	150	165.2	M24

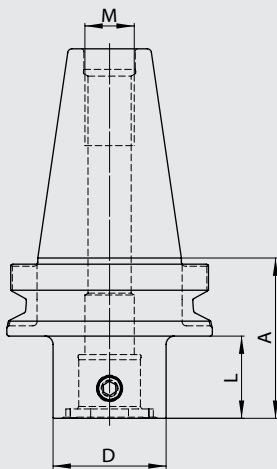

Bestell-Nr. / Order number	BT	System ø D	L	A	M
102.312.201	30	20	20	42	M12
102.312.251	30	25	20	42	M12
102.312.321	30	32	20	42	M12
102.312.421	30	42	20	42	M12
102.312.551	30	55	20	42	M12
102.412.201	40	20	15	42	M16
102.412.202	40	20	40	67	M16
102.412.251	40	25	25	52	M16
102.412.252	40	25	55	82	M16
102.412.321	40	32	25	52	M16
102.412.322	40	32	65	92	M16
102.412.421	40	42	30	57	M16
102.412.422	40	42	80	107	M16
102.412.551	40	55	40	67	M16
102.412.552	40	55	100	127	M16
102.412.721	40	72	60	87	M16
102.412.941	40	94	60	87	M16
102.512.201	50	20	15	53	M24
102.512.202	50	20	40	78	M24
102.512.251	50	25	25	63	M24
102.512.252	50	25	55	93	M24
102.512.321	50	32	25	63	M24
102.512.322	50	32	65	103	M24
102.512.421	50	42	30	68	M24
102.512.422	50	42	80	118	M24
102.512.551	50	55	40	78	M24
102.512.552	50	55	100	138	M24
102.512.721	50	72	60	98	M24
102.512.722	50	72	120	158	M24
102.512.941	50	94	60	98	M24
102.512.942	50	94	150	188	M24





Bestell-Nr. / Order number	System ø D	System ø D1	L	L1	L2
122.250.201	25	20	30	15	54
122.320.201	32	20	30	15	54
122.320.251	32	25	40	25	74
122.420.201	42	20	35	15	54
122.420.251	42	25	40	25	74
122.420.321	42	32	45	25	89
122.550.201	55	20	40	15	54
122.550.251	55	25	50	25	74
122.550.321	55	32	50	25	89
122.550.421	55	42	55	30	119
122.720.251	72	25	55	25	74
122.720.321	72	32	55	25	89
122.720.421	72	42	60	30	119
122.720.551	72	55	60	30	144
122.940.321	94	32	60	25	89
122.940.421	94	42	65	30	119
122.940.551	94	55	65	30	144
122.940.721	94	72	80	45	144

• Länge L2 bezeichnet die maximale Ausdrehtiefe mit Zweischneider- oder Feinbohrkopf

• length L2 stands for the maximal boring depth with twin cutter or fine boring head

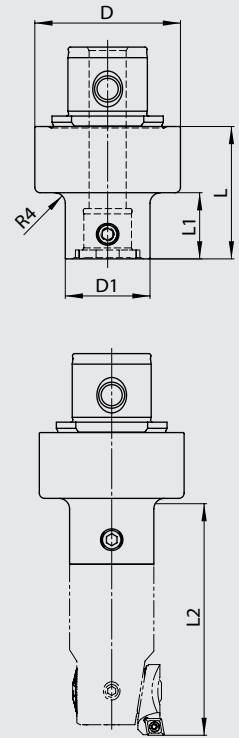

Bestell-Nr. / Order number	System ø D	System ø D1	D2	L	L1	L2
124.550.206	55	20	23.8	95	80	116
124.550.208	55	20	23.8	135	120	156
124.550.256	55	25	30.8	115	100	146
124.550.258	55	25	30.8	165	150	196
124.550.326	55	32	39.8	142	127	188
124.550.328	55	32	39.8	206	191	252
124.550.426	55	42	49.8	177	162	248
124.550.428	55	42	49.8	261	246	332

• Länge L2 bezeichnet die maximale Ausdrehtiefe mit Zweischneider- oder Feinbohrkopf

• length L2 stands for the maximal boring depth with twin cutter or fine boring head

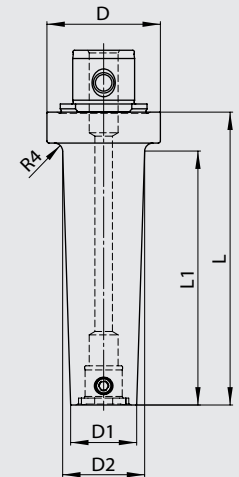

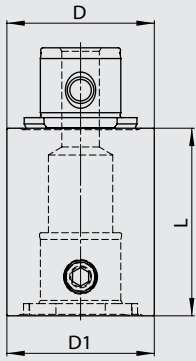

Bestell-Nr. / Order number	System ø D / D1	L
132.200.001	20	25
132.200.002	20	35
132.250.001	25	30
132.250.002	25	45
132.320.001	32	40
132.320.002	32	60
132.420.001	42	50
132.420.002	42	80
132.550.001	55	70
132.550.002	55	105
132.720.001	72	75
132.720.002	72	135
132.940.001	94	100
132.940.002	94	180



Ersatzteile / Zubehör

Spare parts / Accessories

102/122/124/132

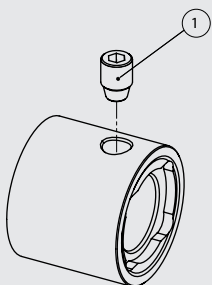

Für System ø D1 For system ø D1	Bestell-Nr. / Order number	Klemmschraube / Clamping screw ①	Gewinde / Thread	SW / AF
20	800.000.200		M5x0.5	2.5
25	800.000.250		M6x0.75	3
32	800.000.320		M8x1	4
42	800.000.420		M12x1	6
55	800.000.550		M12x1	6
72	800.000.720		M16x1.5	8
94	800.000.940		M20x1.5	10



- Durchmessereinstellung mit geringstem Umkehrspiel
- Zustellgenauigkeit von 0.002mm über Nonius im Durchmesser
- mit Innenkühlung

- diametrical adjustment with maximal reduced reversal backlash
- 0.002mm diametrical adjustment by nonius
- with inner coolant supply

Bestell-Nr. / Order number	D	D1	D2	X	L	L1
<i>ANALOG</i>						
262.025.025	4	10	25	1.5	25	25
262.032.032	7	16	32	2.5	32	40

- Schneideinsätze müssen separat bestellt werden.

- Boring bars must be ordered separately

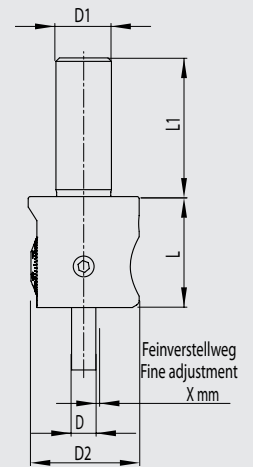

- Einstellgenauigkeit 0.001mm im Durchmesser
- direktes Wegmeßsystem (kein Umkehrspiel)
- keine Batterie und Auswerteelektronik im Werkzeug verbaut
- sehr einfache Bedienung
- digital und analog einsetzbar

- 0.001 accuracy in diameter
- direct measurement system (no backlash)
- no battery and electronic evaluation unit inside the tool
- very easy operation
- for digital and analog use

Bestell-Nr. / Order number	D	D1	D2	X	L	L1
<i>DIGITAL</i>						
263.025.025	4	10	25	1.5	25	25
263.032.032	7	16	32	2.5	32	40

- Anzeigeeinheit muss separat bestellt werden siehe Seite 6 (266.028.077).

- Display unit must be ordered separately see page 6 (266.028.077).

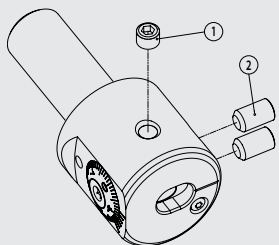
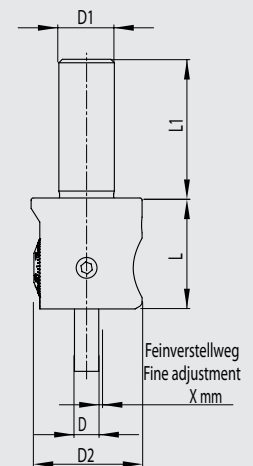

Ersatzteile / Zubehör

Spare parts / Accessories

Für Ausdrehkopf For boring head	Bestell-Nr. / Order number	Bestell-Nr. / Order number
	Klemmschraube/ Clamping screw (1)	Befestigungsschraube / Fastening screw (2)
262/263.025.025	881.262.250	882.262.250
262/263.032.032	881.262.320	882.262.320

Reduktionshülsen

Reduction sleeves

265/268

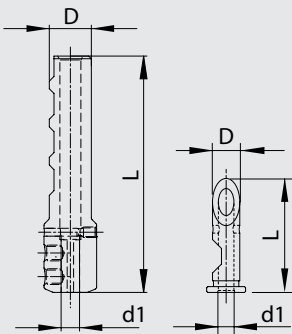

Bestell-Nr. / Order number	D	d1	L
265.007.004	7	4	(30)
268.016.004	16	4	90
268.016.007	16	7	90

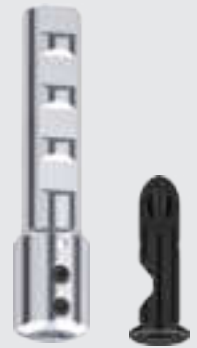

Schneideinsätze

Boring bars

273

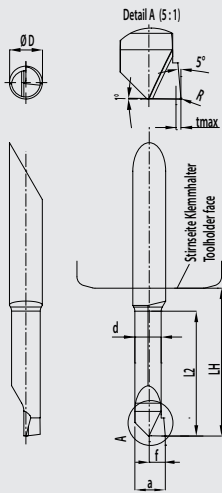

Bestell-Nr. / Order number	ØD	L2	Ød min	Ød max	R	a	d	f	LH	t max	Typ
273.004.003	4.0	1.2	0.3	0.7	-	0.25	0.15	0.15	11.0	0.03	A
273.004.006	4.0	2.5	0.6	1.1	-	0.55	0.46	0.30	11.0	0.05	A
273.004.010	4.0	4.0	1.0	2.3	0.05	0.95	0.65	0.50	11.0	0.1	B
273.004.022	4.0	6.0	2.2	3.3	0.05	2.00	1.55	1.10	11.0	0.2	B
273.004.032	4.0	10.2	3.2	4.3	0.05	3.00	2.55	1.60	11.0	0.2	B
273.004.039	4.0	15.2	3.9	(7.1)	0.05	3.70	3.45	1.95	16.0	0.3	B
273.007.052	7.0	20.3	5.2	6.3	0.05	5.00	4.25	2.60	21.0	0.5	B
273.007.062	7.0	20.3	6.2	7.3	0.05	6.00	5.25	3.10	21.0	0.5	B
273.007.069	7.0	25.4	6.9	(12.1)	0.20	6.70	6.25	3.45	26.0	0.5	B

Schneidplatten

inserts

277

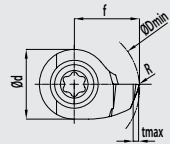

Bestell-Nr. / Order number	Ød min	Ød max	R	f	Ød	S	tmax	Code
277.007.069	6.9	8.1	0.2	3.45	4.8	3.5	1.0	D07
277.007.079	7.9	9.1	0.2	3.95	4.8	3.5	1.0	D07
277.007.089	8.9	10.1	0.2	4.45	4.8	3.5	1.0	D07
277.010.099	9.9	12.1	0.2	4.95	7	3.9	1.0	D10
277.010.119	11.9	14.1	0.2	5.95	7	3.9	1.0	D10
277.010.139	13.9	19.1	0.2	6.95	7	3.9	1.0	D10

• Schnittwerte (Start) f 0.02 mm/U

• Cutting parameters (Start) f 0.02 mm/rev

Adapter
für Schneidplatten

Adapter
for inserts

276

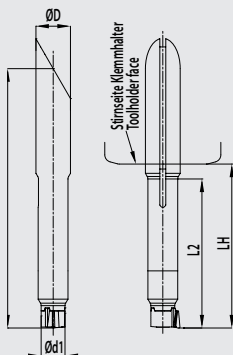

Bestell-Nr. / Order number	ØD h6	L2	Ø d1	L1	LH	Schraube / screw ①	Torx	Code
276.007.007	7.0	30	4.8	56	31	M2x7.5 (843.013.000)	T7	D07
276.007.010	7.0	35	7.0	61	36	M3x9.0 (843.014.000)	T9	D10

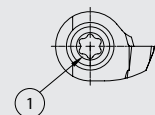

- Durchmessereinstellung mit geringstem Umkehrspiel
- Zustellgenauigkeit von 0.01mm resp. über Nonius 0.002mm im Durchmesser
- mit Innenkühlung
- Ausdrehstähle durchschiebbar (L1)

- diametrical adjustment with maximal reduced reversal backlash
- 0.01mm diametrical adjustment resp. 0.002mm by nonius
- with inner coolant supply
- boring bars go through head (L1)

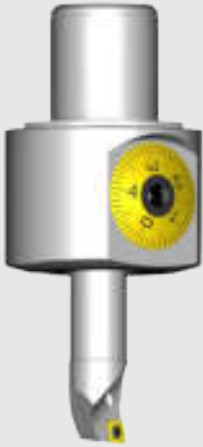

Bestell-Nr./ Order number	System $\varnothing D$	D1	$\varnothing A$ min.	$\varnothing A$ max.	L	L1
MBM modular ANALOG						
262.420.000	42	10	3	19	45	40
262.550.045	55	16	3	88.1	45	75
DIN 69893 HSK 63 A						
269.063.095	55	16	3	88.1	95	70
DIN 69871 AD 40						
269.415.090	55	16	3	88.1	90	80
MAS BT 40						
269.412.090	55	16	3	88.1	90	80

- die Ausdrehdurchmesser $\varnothing A$ min. - A max. werden mit Ausdrehstählen der Serien 271 bis 278 erreicht

- boring diameter $\varnothing A$ min. - A max. are only available with boring bars from series 271 to 278

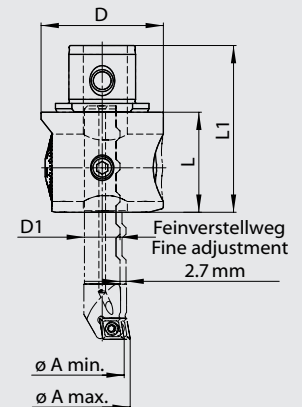

- für Ausdrehstähle mit Schaftdurchmesser 16mm
- Einstellgenauigkeit 0.001mm im Durchmesser
- direktes Wegmeßsystem (kein Umkehrspiel)
- keine Batterie und Auswerteelektronik im Werkzeug verbaut
- sehr einfache Bedienung
- digital und analog einsetzbar
- mit Innenkühlung
- Ausdrehstähle durchschiebbar

- for boring bars with a shank diameter of 16mm
- 0.001 accuracy in diameter
- direct measurement system (no backlash)
- no battery and electronic evaluation unit inside the tool
- very easy operation
- for digital and analog use
- with inner coolant supply
- boring bars go through head

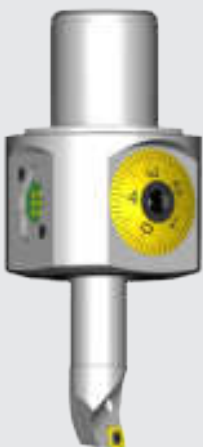

Bestell-Nr./ Order number	System $\varnothing D$	D1	$\varnothing A$ min.	$\varnothing A$ max.	L	L1
MBM modular DIGITAL						
266.550.045	55	16	3	88.1	45	75
DIN 69893 HSK 63 A						
266.063.095	55	16	3	88.1	95	70
DIN 69871 AD 40						
266.415.090	55	16	3	88.1	90	80
MAS BT 40						
266.412.090	55	16	3	88.1	90	80

- die Ausdrehdurchmesser $\varnothing A$ min. - A max. werden mit Ausdrehstählen der Serien 271 bis 278 erreicht

- boring diameter $\varnothing A$ min. - A max. are only available with boring bars from series 271 to 278

- Anzeigeeinheit muss separat bestellt werden siehe Seite 6 (266.028.077).

- Display unit must be ordered separately see page 6 (266.028.077).

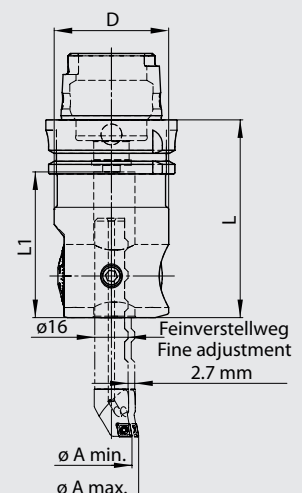
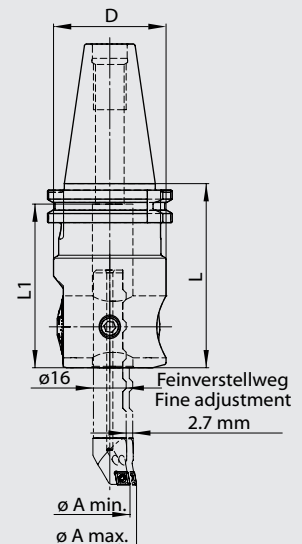

Ausdrehkopf ø3-88.1

Fine boring head ø3-88.1

ECO LINE 262

- Schnittstelle ER32 DIN6499

- connection ER32 DIN 6499

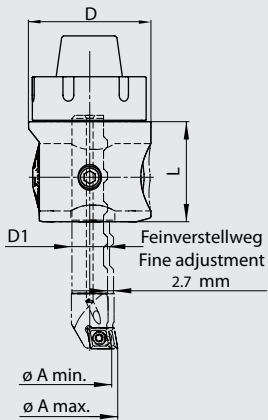

Bestell-Nr. / Order number	Ø D/ System	Ø A min.	Ø A max.	L (A)	L1
SMART ER32					
262.032.060	55 / ER32	9.75	88.1	60	-

- Werkzeug in einem Spannzangenfutter spannen.

- Clamp tool in a collet chuck.



**Ausdrehköpfe ø3-88.1
DIGITAL**

**Fine boring heads ø3-88.1
DIGITAL**

PSC FBHO

- für Ausdrehstähle mit Schaftdurchmesser 16mm
- Einstellgenauigkeit 0.001mm im Durchmesser
- direktes Wegmeßsystem (kein Umkehrspiel)
- keine Batterie und Auswerteelektronik im Werkzeug verbaut
- sehr einfache Bedienung
- digital und analog einsetzbar
- mit Innenkühlung

- for boring bars with a shank diameter of 16mm
- 0.001 accuracy in diameter
- direct measurement system (no backlash)
- no battery and electronic evaluation unit inside the tool
- very easy operation
- for digital and analog use
- with inner coolant supply

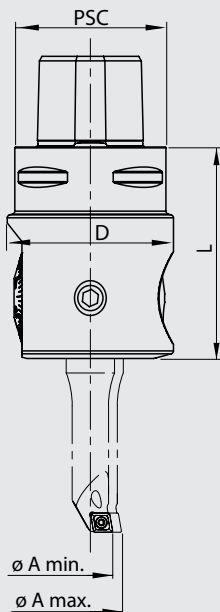

Bestell-Nr. / Order number	System	D1	ø A min.	ø A max.	L (A)	L1
PSC DIGITAL						
PSC40-FBHO-DE-1665	PSC40	55	3	88.1	65	-
PSC50-FBHO-DE-1670	PSC50	55	3	88.1	70	-
PSC63-FBHO-DE-1690	PSC63	55	3	88.1	90	-

- die Ausdrehdurchmesser ø A min. - A max. werden mit Ausdrehstählen der Serien 271 bis 278 erreicht

- boring diameter ø A min. - A max. are only available with boring bars from series 271 to 278



- Anzeigeeinheit muss separat bestellt werden siehe Seite 6 (266.028.077).

- Display unit must be ordered separately see page 6 (266.028.077).



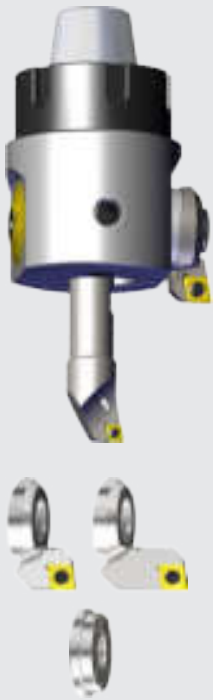

- Schnittstelle ER40 DIN6499
- Zustellgenauigkeit 0.01mm resp. über Nonius 0.002mm im Durchmesser
- erweiterbar von ø3 bis ø152.1

- connection ER40 DIN 6499
- 0.01mm diametrical adjustment resp. 0.002mm by nonius
- can be upgraded from ø3 up to ø152.1

Bestell-Nr. / Order number	Ø D/ System	Ø A min. - max.	Ø A1 min. - max.	L (A)	L2
VARIO ER40					
267.003.152	63 / ER40	3 - 88.1	87.75 - 152.1	50.5	57

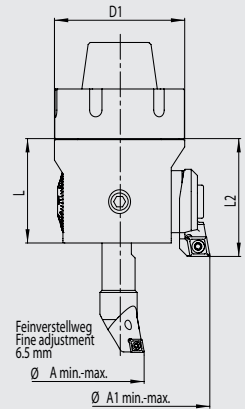

- die Ausdrehdurchmesser ø A min. - A max. werden mit Ausdrehstäben der Serien 271 bis 278 erreicht

- boring diameter ø A min. - A max. are only available with boring bars from series 271 to 278

Zubehör	Accessories
Wendeplattenhalter / Insert holder CC . . 09 T3 . .	ø 87.75 - 101.1 (ø 114.1) 254.261.009
Wendeplattenhalter / Insert holder CC . . 09 T3 . .	ø 105.75 - 119.0 (ø 132.0) 254.262.009
Wendeplattenhalter / Insert holder CC . . 09 T3 . .	ø 125.75 - 139.0 (ø 152.0) 254.263.009
Distanzstück / Adapter F = 6.5 mm	ø 114.0 / ø 132.0 / ø 152.0 889.000.006

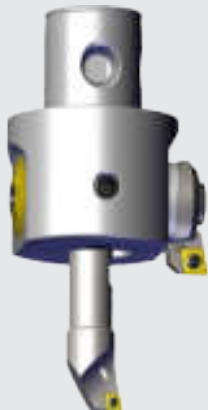

- für Ausdrehstäbe mit Schaftdurchmesser 16mm
- DurchmesserEinstellung mit geringstem Umkehrspiel
- Zustellgenauigkeit von 0.01mm resp. über Nonius 0.002mm im Durchmesser
- mit Innenkühlung
- Ausdrehstäbe durchschiebbar

- for boring bars with a shank diameter of 16mm
- diametrical adjustment with maximal reduced reversal backlash
- 0.01mm diametrical adjustment resp. 0.002mm by nonius
- with inner coolant supply
- boring bars go through head

Bestell-Nr. / Order number	System	L	L2	Ø A min. - max.	Ø A1 min. - max.
VARIO MBM 55					
267.550.152	MBM 55	50	57	3 - 88.1	87.75 - 152.1

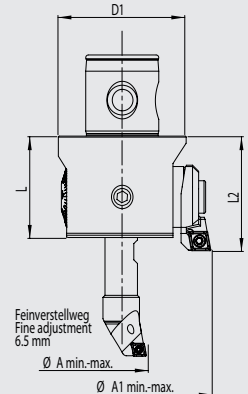

- die Ausdrehdurchmesser ø A min. - A max. werden mit Ausdrehstäben der Serien 271 bis 278 erreicht

- boring diameter ø A min. - A max. are only available with boring bars from series 271 to 278

Zubehör	Accessories
Wendeplattenhalter / Insert holder CC . . 09 T3 . .	ø 87.75 - 101.1 (ø 114.1) 254.261.009
Wendeplattenhalter / Insert holder CC . . 09 T3 . .	ø 105.75 - 119.0 (ø 132.0) 254.262.009
Wendeplattenhalter / Insert holder CC . . 09 T3 . .	ø 125.75 - 139.0 (ø 152.0) 254.263.009
Distanzstück / Adapter F = 6.5 mm	ø 114.0 / ø 132.0 / ø 152.0 889.000.006

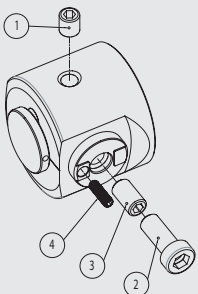

Ersatzteile / Zubehör

Spare parts / Accessories

Für Feinbohrkopf	Bestell-Nr. / Order number	Bestell-Nr. / Order number	Bestell-Nr. / Order number	Bestell-Nr. / Order number
For fine boring head	Klemmschraube / Clamping screw ①	Schraube / Screw ②	Schraube / Screw ③	Schraube / Screw ④
267.003.152	881.267.012	880.267.025	881.267.018	881.267.014

Ausdrehkopf ø3-320

Fine boring head ø3-320

- für Ausdrehstähle mit Schaftdurchmesser 16mm und Feinbohrbrücken
- DurchmesserEinstellung mit geringstem Umkehrspiel
- Zustellgenauigkeit von 0.002mm über Nonius im Durchmesser
- mit Innenkühlung
- Ausdrehstähle durchschiebbar
- for boring bars with a shank diameter of 16mm and fine boring bridges
- diametrical adjustment with maximal reduced reversal backlash
- 0.002mm diametrical adjustment by nonius
- with inner coolant supply
- boring bars go through head

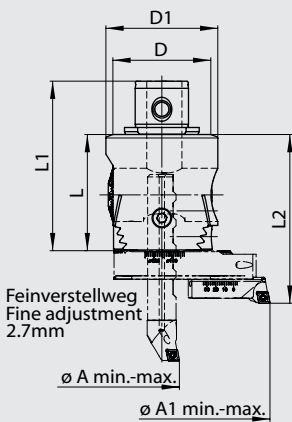

Bestell-Nr. / Order number	System ø D	D1	ø A min.- max.	ø A1 min.- max.	L	L1	L2
MBM 55 modular							
261.550.065	55	63	3 - 88.1	86 - 320	66	96	95
DIN 69893 HSK 63 A							
261.063.095	-	63	3 - 88.1	86 - 320	96	72.5	125
DIN 69871 AD 40							
261.415.090	-	63	3 - 88.1	86 - 320	91	81	120
MAS BT 40							
261.412.090	-	63	3 - 88.1	86 - 320	91	81	120

- die Ausdrehdurchmesser ø A min.-max. werden mit Ausdrehstählen der Serien 271 bis 278 erreicht
- die Ausdrehdurchmesser ø A1 min.-max. werden mit Feinbohrbrücken der Serie 886 erreicht
- boring diameters ø A min.-max. are only available with boring bars from series 271 to 278
- boring diameters ø A min.-max. are only available with fine boring bridges from serie 886



Feinbohrbrücken ø86-320

Fine boring bridges ø86-320

Aluminium-Brücken

- mit Innenkühlung

Aluminium bridges

- with inner coolant supply

Bestell-Nr. / Order number	D	ø A min.	ø A max.
886.086.164	80	86	164
886.162.320	158	162	320

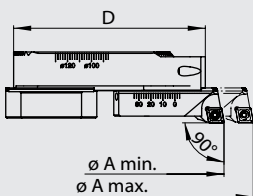

Wendeplattenhalter

- mit Innenkühlung

Insert holders

- with inner coolant supply

Bestell-Nr. / Order number	Wendeplatte / Insert	ø A min.	ø A max.
253.048.006	CC .. 06 02 ..	86	320
253.048.009	CC .. 09 T3 ..	86	320



Gegengewicht

- zum Feinwuchten auf Wuchtgerät

Counter weight

- to balance with balancing machine

Bestell-Nr. / Order number
886.038.045



Ersatzteile / Zubehör

Spare parts / Accessories

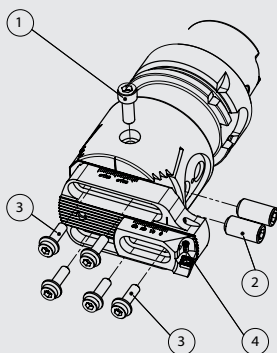

Für Ausdrehkopf For boring head	Bestell-Nr. / Order number	Bestell-Nr. / Order number	Bestell-Nr. / Order number
	Klemmschraube / Clamping screw ①	Befestigungsschraube / Fastening screw ②	Befestigungsschraube / Fastening screw ③
261.xxx.xxx	881.261.016	881.261.020	883.261.016
262.420.000	881.262.420	882.262.420	
262/266.550.045	881.262.551	882.262.551	
Für Wp-Halter For insert holder	Bestell-Nr. / Order number	Bestell-Nr. / Order number	
	Torx-Schraube / Torx screw ④	Torx-Schlüssel / Torx driver	
253.048.006	843.006.000	842.006.000	
253.048.009	843.009.000	842.009.000	

**High-Speed Ausdrehstähle
ø8.75-40.1 (Hartmetallschaft)**

**High-Speed boring bars
ø8.75-40.1 (solid carbide shank)**

- zum Ausdrehen von langen Bohrungen
- sehr gute Dämpfungseigenschaften durch Hartmetallschaft
- mit Innenkühlung
- to machine long holes
- high end absorbability by solid carbide shank
- with inner coolant supply



HS-Kopf / HS-head Bestell-Nr./ Order number	HS-Schaft / HS-shank Bestell-Nr./ Order number	ø A min.	ø A max.	D	L	L1	Wende- platte / Insert
278.087.005	276.008.005	8.75	14.1	8	56	91	CC..06 02..
278.097.005	276.009.005	9.75	15.1	9	63	98	CC..06 02..
278.107.006	276.010.006	10.75	16.1	10	70	105	CC..06 02..
278.117.006	276.011.006	11.75	17.1	11	77	112	CC..06 02..
278.127.006	276.012.006	12.75	18.1	12	84	119	CC..06 02..
278.137.006	276.013.006	13.75	19.1	13	91	126	CC..06 02..
278.147.006	276.014.006	14.75	20.1	14	98	133	CC..06 02..
278.157.006	276.014.006	15.75	21.1	14	98	133	CC..06 02..
278.167.006	276.016.010	16.75	22.1	16	112	147	CC..06 02..
278.177.006	276.016.010	17.75	23.1	16	112	147	CC..06 02..
278.197.006	276.016.010	19.75	25.1	16	112	147	CC..06 02..
278.217.006	276.016.010	21.75	27.1	16	112	147	CC..06 02..
278.247.006	276.016.010	24.75	30.1	16	112	147	CC..06 02..
278.277.006	276.016.010	27.75	33.1	16	112	147	CC..06 02..
278.317.006	276.016.010	31.75	37.1	16	112	147	CC..06 02..
278.347.006	276.016.010	34.75	40.1	16	112	147	CC..06 02..

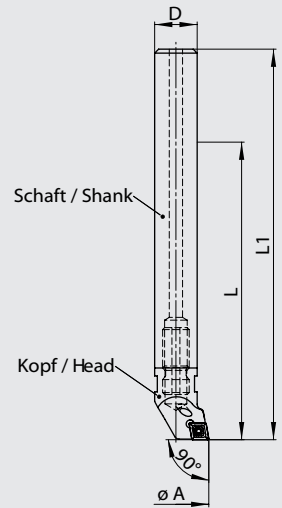

- Einstellen der Schneidhöhe auf Werkzeugzentrum für alle Ausdrehstähle ohne Spannfläche
- Adjusting the tip height on tool centre for boring bars without clamping flat

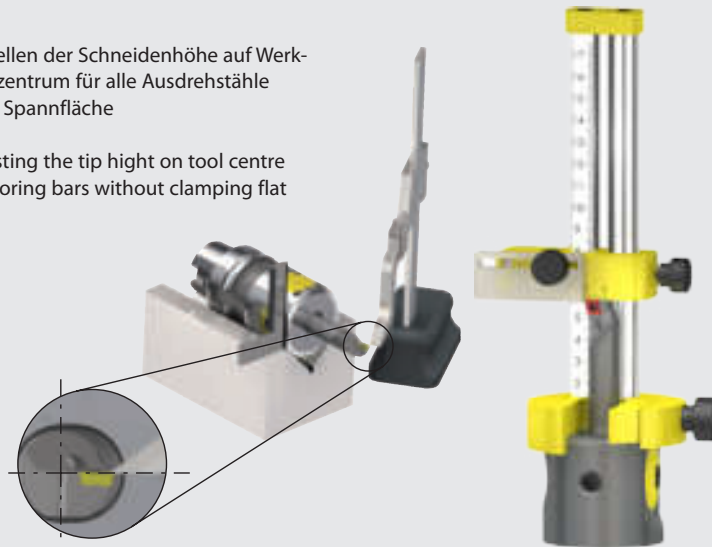

**Ausdrehstähle
mit Hartmetallschaft**

**Boring bars
with solid carbide shank**



Bestell-Nr./ Order number	ø A min.	ø A max.	D	L	L1	Wendeplatte / Insert
274.006.002	5.8	11.2	5	50	85	WC..02 01..
274.008.002	7.8	13.2	6	60	95	WC..02 01..
274.010.006	9.8	15.0	8	80	120	CC..06 02..
274.014.006	13.8	19.0	10	100	140	CC..06 02..
274.018.009	17.8	23.0	12	120	170	CC..09 T3..
274.022.009	21.8	27.0	16	160	210	CC..09 T3..

- Länge L bezeichnet die maximale Ausdrehlänge
- die Ausdrehdurchmesser ø A min. - A max. werden mit Ausdrehköpfen der Serien 261 bis 269 erreicht
- length L stands for the maximal boring depth
- boring diameters ø A min. - A max. are only available with fine boring heads from series 261 to 269

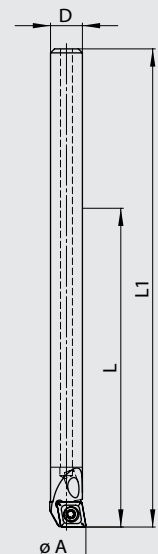

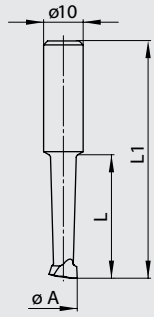

Bestell-Nr. / Order number	$\varnothing A$ min.	$\varnothing A$ max.	L1	L	HM Sorte / Carbide quality
275.003.010	3.0	8.0	46	20	K10
275.003.020	3.0	8.0	46	20	P20
275.004.010	4.0	9.0	51	23	K10
275.004.020	4.0	9.0	51	23	P20
275.005.010	5.0	10.0	52	25	K10
275.005.020	5.0	10.0	52	25	P20
275.006.010	6.0	11.0	56	28	K10
275.006.020	6.0	11.0	56	28	P20
275.007.010	7.0	12.0	60	31	K10
275.007.020	7.0	12.0	60	31	P20
275.009.010	9.0	14.0	64	34	K10
275.009.020	9.0	14.0	64	34	P20
275.010.010	10.0	15.0	68	37	K10
275.010.020	10.0	15.0	68	37	P20
275.012.010	12.0	17.0	72	40	K10
275.012.020	12.0	17.0	72	40	P20
275.014.010	14.0	19.0	77	43	K10
275.014.020	14.0	19.0	77	43	P20



- die Ausdrehdurchmesser $\varnothing A$ min. - A max. werden mit Ausdrehköpfen der Serien 261 bis 269 erreicht
- Hartmetall Sorte K10 für Guss, Aluminium usw.
- Hartmetall Sorte P20 für Stahl, Chromnickelstahl usw.
- boring diameters $\varnothing A$ min. - A max. are only available with fine boring heads from series 261 to 269
- carbide quality K10 for cast iron, aluminium etc.
- carbide quality P20 for steel, chrome nickel steel etc.

Reduktionshülsen

Reduction sleeves

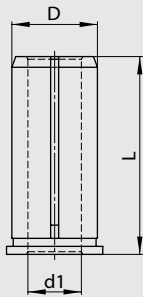

Bestell-Nr. / Order number	D	d1	L
265.010.004	10	4	29.5
265.010.005	10	5	29.5
265.010.006	10	6	29.5
265.010.008	10	8	29.5
265.016.004	16	4	37
265.016.005	16	5	37
265.016.006	16	6	37
265.016.008	16	8	37
265.016.009	16	9	37
265.016.010	16	10	37
265.016.011	16	11	37
265.016.012	16	12	37
265.016.013	16	13	37
265.016.014	16	14	37



Ersatzteile / Zubehör

Spare parts / Accessories

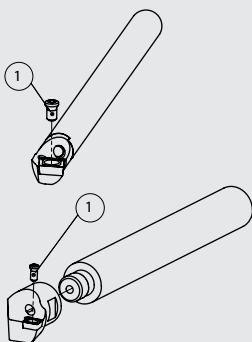

Für Ausdrehstahl For boring bar	Bestell-Nr. / Order number	Bestell-Nr. / Order number
	Torx-Schraube / Torx screw ①	Torx-Schlüssel / Torx driver
274.xxx.002	843.005.000	842.005.000
274.010.006	843.007.000	842.006.000
274.xxx.006	843.006.000	842.006.000
274.xxx.009	843.009.000	842.009.000
Für Kopf For head		
278.087.005-278.117.006	843.007.000	842.006.000
278.127.006-278.347.006	843.006.000	842.006.000

- mit Innenkühlung
- werden die Ausdrehstähle zentrisch gespannt (Weldonfutter), kann mit $\varnothing A$ min. ausgedreht werden

- with inner coolant supply
- if the boring bars are clamped centrally (weldon adapter), the minimum diameter ($\varnothing A$ min.) is provided

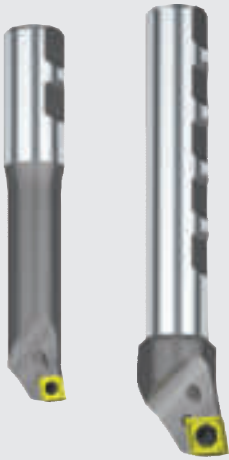

Bestell-Nr. / Order number	$\varnothing A$ min.	$\varnothing A$ max.	L	L1	Wendeplatte / Insert
272.010.006	9.75	15.1	30	75	CC .. 06 02 ..
272.012.006	11.75	17.1	37	80	CC .. 06 02 ..
272.014.006	13.75	19.1	43	85	CC .. 06 02 ..
272.015.006	14.75	20.1	51	90	CC .. 06 02 ..
272.016.006	15.75	21.1	57	95	CC .. 06 02 ..
272.018.006	17.75	23.1	67	100	CC .. 06 02 ..
272.020.006	19.75	25.1	72	105	CC .. 06 02 ..
272.020.009	19.75	25.1	72	105	CC .. 09 T3 ..
272.022.009	21.75	27.1	77	110	CC .. 09 T3 ..
272.025.006	24.75	30.1	82	115	CC .. 06 02 ..
272.025.009	24.75	30.1	82	115	CC .. 09 T3 ..
272.028.009	27.75	33.1	82	115	CC .. 09 T3 ..
272.030.006	29.75	35.1	82	115	CC .. 06 02 ..
272.032.009	31.75	37.1	82	115	CC .. 09 T3 ..
272.035.006	34.75	40.1	82	115	CC .. 06 02 ..
272.035.009	34.75	40.1	82	115	CC .. 09 T3 ..
272.039.009	38.75	44.1	82	115	CC .. 09 T3 ..
272.043.009	42.75	48.1	82	115	CC .. 09 T3 ..
272.048.009	47.75	53.1	82	115	CC .. 09 T3 ..

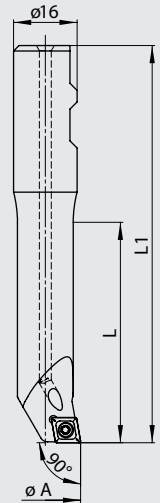

- mit Innenkühlung
- werden die Ausdrehstähle zentrisch gespannt (Weldonfutter), kann mit $\varnothing A$ min. ausgedreht werden

- with inner coolant supply
- if the boring bars are clamped centrally (weldon adapter), the minimum diameter ($\varnothing A$ min.) is provided



Bestell-Nr. / Order number	$\varnothing A$ min.	$\varnothing A$ max.	L	L1	Wendeplatte / Insert
273.010.T06	9.75	15.1	30	75	TB .. 06 01 ..
273.012.T06	11.75	17.1	37	80	TB .. 06 01 ..
273.014.T09	13.75	19.1	43	85	TP .. 09 02 ..
273.015.T09	14.75	20.1	51	90	TP .. 09 02 ..
273.016.T09	15.75	21.1	57	95	TP .. 09 02 ..
273.018.T09	17.75	23.1	67	100	TP .. 09 02 ..
273.020.T11	19.75	25.1	72	105	TP .. 11 03 ..
273.025.T11	24.75	30.1	82	115	TP .. 11 03 ..

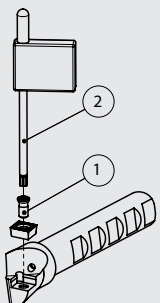
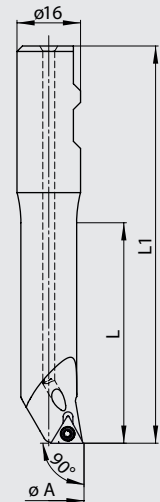

Ersatzteile / Zubehör

Spare parts / Accessories

272

Für Ausdrehstahl For boring bar	Bestell-Nr. / Order number	Bestell-Nr. / Order number
	Torx-Schraube / Torx screw ①	Torx-Schlüssel / Torx driver ②
272.010-012.006	843.007.000	842.006.000
272.xxx.006	843.006.000	842.006.000
272.xxx.009	843.009.000	842.009.000

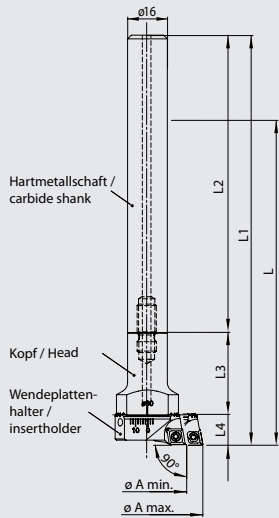

Hartmetallschaft

- sehr gute Dämpfungseigenschaften
- mit Innenkühlung

Carbide shank

- high end absorability
- with inner coolant supply

Bestell-Nr. / Order number	D	L2	für Kopf / for head
276.016.010	16	120	271.130.033 271.148.031

Kopf

- mit Innenkühlung

Head

- with inner coolant supply

Bestell-Nr. / Order number	ø A min.	ø A max.	L	L1	L3	für Wendeplattenhalter / for insert holder
271.130.033	29.75	48.1	135	165	33	253.030.006
271.148.031	47.75	88.1	135	165	31	253.048.xxx

- Wendeplattenhalter müssen separat bestellt werden

- insert holder must be ordered separately

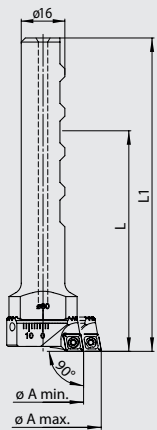

Stahlschäfte

- mit Innenkühlung

Steel shanks

- with inner coolant supply

Bestell-Nr. / Order number	ø A min.	ø A max.	L	L1	für Wendeplattenhalter / for insert holder
271.030.048	29.75	48.1	85	115	253.030.006
271.048.088	47.75	88.1	85	115	253.048.xxx

- Wendeplattenhalter müssen separat bestellt werden

- insert holder must be ordered separately



Wendeplattenhalter

- mit Innenkühlung

Insert holders

- with inner coolant supply

Bestell-Nr. / Order number	ø A min.	ø A max.	Wendeplatte / Insert	für Schaft / for shank
253.030.006	29.75	48.1	CC . . 06 02 . .	271.030.048 271.130.033
253.048.006	47.75	88.1	CC . . 06 02 . .	271.048.088 271.148.031
253.048.009	47.75	88.1	CC . . 09 T3 . .	271.048.088 271.148.031

- Schäfte und Wendeplattenhalter müssen separat bestellt werden

- shanks and insert holder must be ordered separately

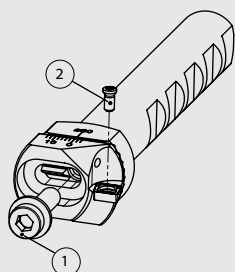

Ersatzteile / Zubehör

Spare parts / Accessories

Für Schaft For shank	Bestell-Nr. / Order number	Für Wp-Halter For insert holder	Bestell-Nr. / Order number	Bestell-Nr. / Order number
	Befestigungsschraube / Fastening screw (1)		Torx-Schraube / Torx screw (2)	Torx-Schlüssel / Torx driver
271.030.048	883.261.016	253.xxx.006	843.006.000	842.006.000
271.048.088	883.261.016	253.xxx.009	843.009.000	842.009.000

Einstellvorrichtung

Setting Jig

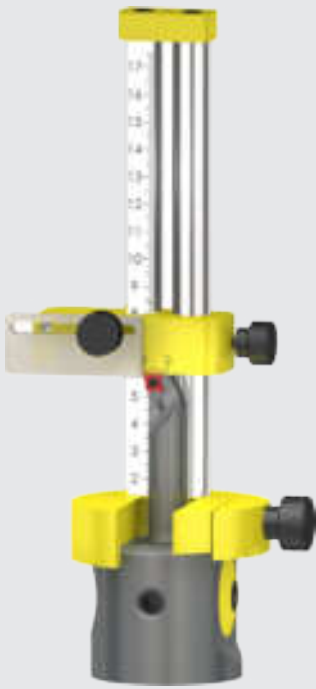

- Orientierung der Werkzeugschneide
- Einstellung der Auskraglänge der Bohrstange
- Grobeinstellung des Ausdrehdurchmessers

- alignment of the cutting edge
- adjustment of the boring bar projection length
- coarse diameter adjustment

Bestell-Nr. / Order number	D	L	für Ausdrehkopf / for fine boring head
260.055.197	55	197	262/266/269
260.163.207	63	207	261

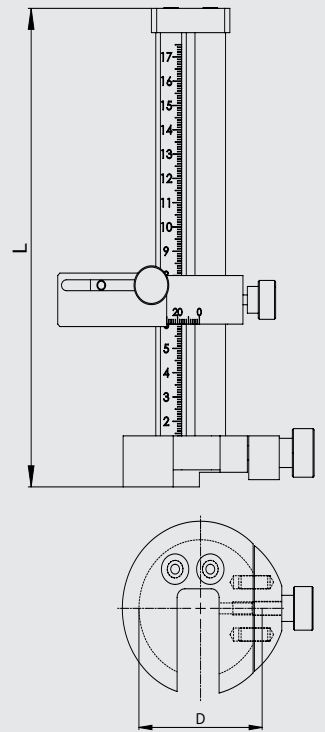

Universal-Auswuchtringe

Universal balancing rings

- zum Auswuchten verstellbarer Werkzeuge, z.B. Ausdrehköpfe der Serien 262 - 269
- für die Ausdrehköpfe der Serie 262 und 263 (mit den Ausdrehstäben der Serie 272,274,276,278) sind Einstelltabelle verfügbar, womit die Unwucht über 90% reduziert wird

- to balance adjustable tools, e.g. fine boring heads from series 262-269
- balancing charts for fine boring heads from serie 262 and 263 (with boring bars from serie 272,274,276,278) are available in order to reduce unbalance by 90%



Bestell-Nr. / Order number	D	d1	L	Ausdrehkopf / Fine boring head
264.550.100	75	55	16	262.550.045 269.412.090
264.630.100	84	63	16	263.550.065 263.412.090

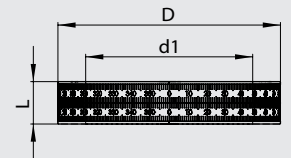

Ausdrehstahl-Verlängerungen

Boring bar extensions



Bestell-Nr. / Order number	D	d1	D2	L	L1
268.016.010	16	10	16	128	-
268.016.016	16	16	24	148	44

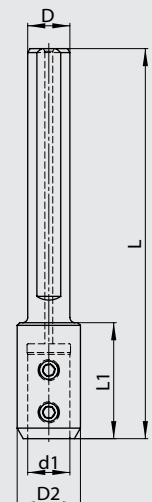

- für die Verwendung in Ausdrehköpfen der Serien 261 bis 269
- mit Innenkühlung

- for use in fine boring heads from series 261 to 269
- with inner coolant supply

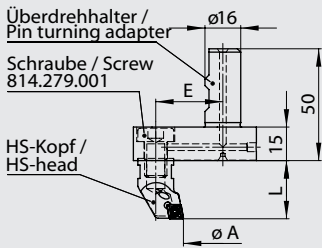

Überdrehhalter / Pin turning adapter Bestell-Nr. / Order number	HS-Kopf / HS-head Bestell-Nr. / Order number	ø A min.	ø A max.	E	L	Wende- platte / Insert
279.020.010	278.347.006	5.3	10.6	20	27	CC..06 02..
279.020.010	278.317.006	8.3	13.6	20	27	CC..06 02..
279.020.010	278.277.006	12.3	17.6	20	27	CC..06 02..
279.020.010	278.247.006	15.3	20.6	20	27	CC..06 02..
279.020.010	278.217.006	18.3	23.6	20	27	CC..06 02..
279.020.010	278.197.006	20.3	25.6	20	27	CC..06 02..
279.020.010	278.177.006	22.3	27.6	20	27	CC..06 02..
279.020.010	278.167.006	23.3	28.6	20	27	CC..06 02..
279.030.010	278.347.006	25.3	30.6	30	27	CC..06 02..
279.030.010	278.317.006	28.3	33.6	30	27	CC..06 02..
279.030.010	278.277.006	32.3	37.6	30	27	CC..06 02..
279.030.010	278.247.006	35.3	40.6	30	27	CC..06 02..
279.030.010	278.217.006	38.3	43.6	30	27	CC..06 02..
279.030.010	278.197.006	40.3	45.6	30	27	CC..06 02..
279.030.010	278.177.006	42.3	47.6	30	27	CC..06 02..
279.030.010	278.167.006	43.3	48.6	30	27	CC..06 02..



- die maximale Überdrehlänge L kann mit der Verlängerung 286.016.032 oder 286.016.064 verlängert werden
- Überdrehhalter und Kopf müssen separat bestellt werden
- **Achtung: Linkslauf**

- the maximal turning length L can be increased by extension 286.016.032 or 286.016.064
- pin turning adapter and head must be ordered separately
- **Caution: anticlockwise rotation**

HS-Schaftverlängerungen

HS-shank extensions

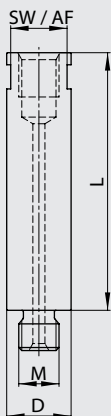

- zur Verlängerung von HS-Schäften und Überdrehhalter
- mit Innenkühlung
- aus gehärtetem Stahl

- to extend HS-shanks and pin turning adapter
- with inner coolant supply
- made of hardened steel

Bestell-Nr. / Order number	D	L	M	SW / AF
286.016.032	16	32	M10	14
286.016.064	16	64	M10	14

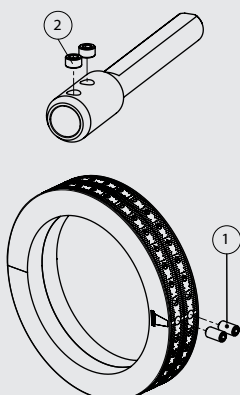

Ersatzteile / Zubehör

Spare parts / Accessories

Für Auswuchtring For balancing ring	Bestell-Nr. / Order number	Für Ausdrehstahl-Verlängerung For boring bar extension	Bestell-Nr. / Order number
	Klemmschraube / Clamp screw ¹		Spannschraube / Clamp screw ²
264.xxx.100	857.550.000	268.016.010	855.268.006
		268.016.016	855.268.008



Schaft / shank Bestell-Nr. / Order number	D	L1	für Feinbohrkopf / for fine boring head
276.014.006	14	110	280.140.000
276.016.010	16	120	280.160.000
276.018.010	18	100	280.190.000
276.018.110	18	140	280.190.000

Stahlschaft

Steel shank

Schaft / shank Bestell-Nr. / Order number	D	L1	für Feinbohrkopf / for fine boring head
288.014.060	14	60	280.140.000
288.016.070	16	70	280.160.000
288.018.080	18	80	280.190.000

High-Speed Feinbohrköpfe

High-Speed fine boring heads

- Durchmessereinstellung mit geringstem Umkehrspiel
- Zustellgenauigkeit von 0.002mm über Nonius im Durchmesser
- mit Innenkühlung

- diametrical adjustment with maximal reduced reversal backlash
- 0.002mm diametrical adjustment by nonius
- with inner coolant supply

Feinbohrkopf / Fine boring head Bestell-Nr. / Order number	D	ø A min.	ø A max.	L	für Wendeplattenhalter / For insert holder (Wendeplatte / Insert)
280.140.000	14	14.7	17.1	40	282.005.002 (WC .. 02 01 ..)
280.160.000	16	16.7	20.1	40	282.005.002 (WC .. 02 01 ..)
280.190.000	18	19.7	24.1	40	282.005.002 (WC .. 02 01 ..)

- Feinbohrkopf, Schaft und Wendeplattenhalter müssen separat bestellt werden

- fine boring head, shank and insert holder must be ordered separately

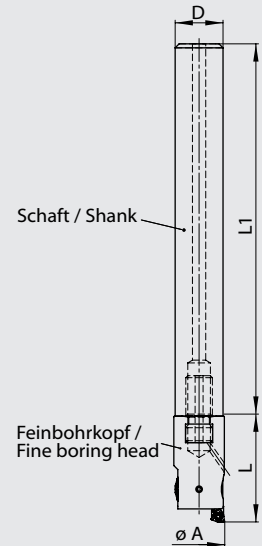

Ersatzteile / Zubehör

Spare parts / Accessories

251/252/280

Für Feinbohrkopf For fine boring head	Bestell-Nr. / Order number	Bestell-Nr. / Order number
	Klemmschraube / Clamping screw ^①	Befestigungsschraube / Fastening screw ^②
280.140.000	881.280.140	882.280.140
280.160.000	881.280.160	882.280.140
280.190.000	881.280.190	882.280.140
280/281.020.041	881.252.200	880.252.200
280/281.025.045	881.252.250	880.252.250
280/281.032.051	881.252.320	880.252.320
251/252.200.000	881.252.200	880.252.200
251/252.250.000	881.252.250	880.252.250
251/252.320.000	881.252.320	880.252.320
251/252.420.000	881.252.420	880.252.420
251/252.550.000	881.252.550	880.252.550
251/252.720.100	881.252.720	880.252.550
251/-252.940.100	881.252.940	880.252.550

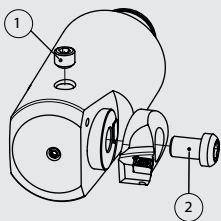

- **Typ 280 (analog)** Zustellgenauigkeit von 0.002mm über Nonius im Durchmesser
- **Typ 281 (digital)** Einstellgenauigkeit 0.001mm im Durchmesser direktes Wegmeßsystem (kein Umkehrspiel)
- mit Innenkühlung
- **Type 280 (analog)** 0.002mm diametrical adjustment by nonius
- **Type 281 (digital)** 0.001 accuracy in diameter
- direct measurement system (no backlash)
- with inner coolant supply

Bestell-Nr. / Order number	ø A min.	ø A max.	d	L	Wendeplatten- halter / Insert holder
280/281.020.041	23.9	31.1	20	41	254.200.006
280/281.025.045	30.9	40.1	25	45	254.250.006
280/281.032.051	39.9	51.1	32	51	254.320.006

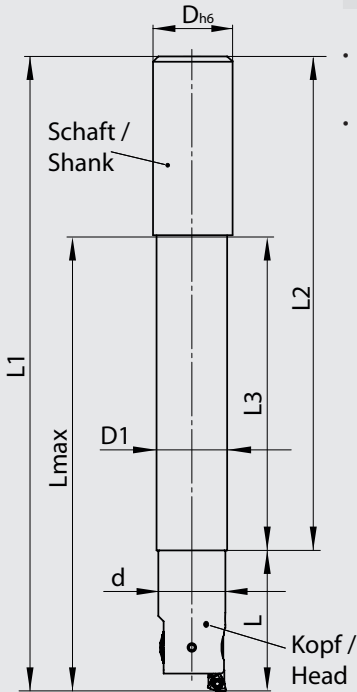

- Wendeplattenhalter müssen separat bestellt werden
- Anzeigeeinheit muss separat bestellt werden siehe Seite 6 (266.028.077).
- insert holders must be ordered separately
- Display unit must be ordered separately see page 6 (266.028.077).

**Schwingungsgedämpfte
Vollhartmetallschäfte**

**Damped
solid carbide shanks**

- Produktivitätsgewinn dank der unterdrückten Schwingungen können die Schnittdaten beträchtlich erhöht werden
- Verbesserte Oberflächengüte
- Verbesserte Prozesssicherheit
- Verbesserte Spanabfuhr
- Reduzierte Kosten pro Bauteil
- Für Bohrungstiefen bis 12xD
- productivity improvement: thanks to reduced vibrations, the cutting conditions can be improved remarkable
- better surface quality
- improved process stability
- better chip evacuation
- reduced cost per part
- for boring length up to 12xD



Bestell-Nr. / Order number	D	D1	L max	L1	L2	L3	für Einschraub- kopf / for screwab- le head
276.025.170	25	23	146	211	170	105	280/140.020.041
276.025.220	25	23	196	261	220	155	280/140.020.041
276.025.265	25	23	241	306	265	200	280/140.020.041
276.032.220	32	29	200	265	220	155	280/140.025.045
276.032.260	32	29	240	305	260	195	280/140.025.045
276.032.310	32	29	290	355	310	245	280/140.025.045
276.032.217	32	32	203	268	217	152	280/140.032.051
276.032.287	32	32	273	338	287	222	280/140.032.051
276.032.357	32	32	343	408	357	292	280/140.032.051



- DurchmesserEinstellung mit geringstem Umkehrspiel
- Zustellgenauigkeit von 0.002mm über Nonius im Durchmesser
- mit Innenkühlung

- diametrical adjustment nearly without reversal backlash
- 0.002mm diametrical adjustment by nonius
- with inner coolant supply



Bestell-Nr./ Order number	System ø D	ø A min.	ø A max.	L	Wendeplattenhalter / Insert holder
252.200.000	20	23.9	31.1	40	254.200.006
		29.9	37.1		254.201.006
252.250.000	25	30.9	40.1	50	254.250.006
		37.9	47.1		254.251.006
252.320.000	32	39.9	51.1	65	254.320.006
		47.9	59.1		254.321.006
252.420.000	42	50.9	67.1	90	254.420.006
		64.9	81.1		254.421.006
252.550.000	55	66.9	87.1	115	254.550.009
		66.9	87.1		254.550.006
252.720.100	72	84.9	105.1	100	254.551.006/9
		86.9	116.1		254.550.009
252.940.100	94	86.9	116.1	130	254.550.006
		104.9	134.1		254.551.006/9
		115.9	153.1		254.550.009
		115.9	153.1		254.550.006
		133.9	171.1		254.551.006/9
		153.9	191.1		254.263.009
		165.9*	203.1*		

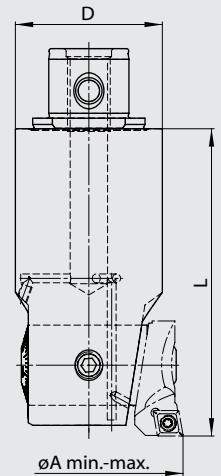

- Wendeplattenhalter müssen separat bestellt werden
- * Hinweis: Dieser Ausdrehbereich wird erreicht mit dem Wendeplattenhalter 254.263.009 in Kombination mit dem Distanzstück 889.000.006.

- insert holders must be ordered separately
- * Note: For this diameter range the insert holder 254.263.009 and the adapter 889.000.006 is required.

- Einstellgenauigkeit 0.001mm im Durchmesser
- direktes Wegmeßsystem (kein Umkehrspiel)
- keine Batterie und Auswerteelektronik im Werkzeug verbaut
- sehr einfache Bedienung
- digital und analog einsetzbar
- mit Innenkühlung

- 0.001 accuracy in diameter
- direct measurement system (no backlash)
- no battery and electronic evaluation unit inside the tool
- very easy operation
- for digital and analog use
- with inner coolant supply



Bestell-Nr./ Order number	System ø D	ø A min.	ø A max.	L	Wendeplattenhalter / Insert holder
251.200.000	20	23.9	31.1	40	254.200.006
		29.9	37.1		254.201.006
251.250.000	25	30.9	40.1	50	254.250.006
		37.9	47.1		254.251.006
251.320.000	32	39.9	51.1	65	254.320.006
		47.9	59.1		254.321.006
251.420.000	42	50.9	67.1	90	254.420.006
		64.9	81.1		254.421.006
251.550.000	55	66.9	87.1	115	254.550.009
		66.9	87.1		254.550.006
251.720.100	72	84.9	105.1	100	254.551.006/9
		86.9	116.1		254.550.009
251.940.100	94	86.9	116.1	130	254.550.006
		104.9	134.1		254.551.006/9
		115.9	153.1		254.550.009
		115.9	153.1		254.550.006
		133.9	171.1		254.551.006/9
		153.9	191.1		254.263.009
		165.9*	203.1*		

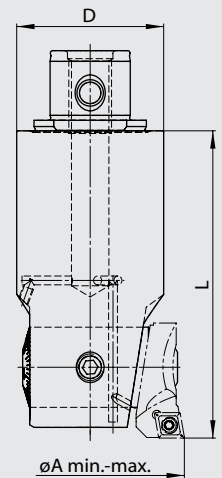

- * Hinweis: Dieser Ausdrehbereich wird erreicht mit dem Wendeplattenhalter 254.263.009 in Kombination mit dem Distanzstück 889.000.006.

- * Note: For this diameter range the insert holder 254.263.009 and the adapter 889.000.006 is required.

- Anzeigeeinheit muss separat bestellt werden siehe Seite 6 (266.028.077).

- Display unit must be ordered separately see page 6 (266.028.077).



Feinbohrköpfe Ø23.9-40.1

Fine boring heads Ø23.9-40.1

ECO LINE Uxx_F

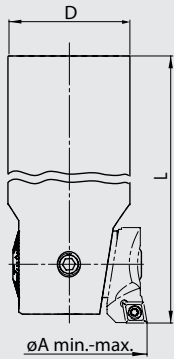

- DurchmesserEinstellung mit geringstem Umkehrspiel
- Zustellgenauigkeit von 0.01mm resp. über Nonius 0.002mm im Durchmesser
- mit Innenkühlung

- diameter setting with minimal reversal backlash
- 0.01mm diametrical adjustment resp. 0.002mm by nonius
- with inner coolant supply

Bestell-Nr. / Order number	Ø D/ System	Ø A min.	Ø A max.	L	Wendeplattenhalter / Insert holder
U20_F20.K21.150	20	23.9	31.1	150	254.200.006 (CC.. 06 02 ..)
U25_F25.K21.170	25	30.9	40.1	170	254.250.006 (CC.. 06 02 ..)

- Werkzeug in einem Spannzangen- oder Hydrodehnfutter spannen.
- **inklusive Wendeplattenhalter**

- Clamp tool in a collet or hydraulik chuck.
- **insert holder included**



ECO LINE

Feinbohrköpfe Ø39.9-87.1

Fine boring heads Ø39.9-87.1

ECO LINE Exx_F

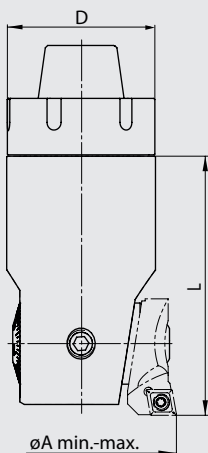

- DurchmesserEinstellung mit geringstem Umkehrspiel
- Zustellgenauigkeit von 0.01mm resp. über Nonius 0.002mm im Durchmesser
- mit Innenkühlung

- diameter setting with minimal reversal backlash
- 0.01mm diametrical adjustment resp. 0.002mm by nonius
- with inner coolant supply

Bestell-Nr. / Order number	Ø D/ System	Ø A min.	Ø A max.	L	Wendeplattenhalter / Insert holder
E25_F32.K21.065	32 / ER25	39.9	51.1	65	254.320.006 (CC.. 06 02 ..)
E32_F42.K21.075	42 / ER32	50.9	67.1	75	254.420.006 (CC.. 06 02 ..)
E40_F55.K21.085	55 / ER40	66.9	87.1	85	254.550.009 (CC.. 09 T3 ..)

- Werkzeug in einem Spannzangenfutter spannen.
- **inklusive Wendeplattenhalter**

- Clamp tool in a collet chuck.
- **insert holder included**



ECO LINE

Feinbohrköpfe Ø23.9-153.1
DIGITAL

Fine boring heads Ø23.9-153.1
DIGITAL

PSC FBHS

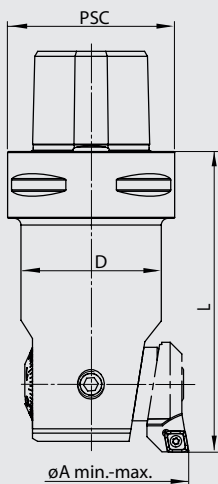

- Einstellgenauigkeit 0.001mm im Durchmesser
- direktes Wegmeßsystem (kein Umkehrspiel)
- keine Batterie und Auswerteelektronik im Werkzeug verbaut
- sehr einfache Bedienung
- digital und analog einsetzbar
- mit Innenkühlung

- 0.001 accuracy in diameter
- direct measurement system (no backlash)
- no battery and electronic evaluation unit inside the tool
- very easy operation
- for digital and analog use
- with inner coolant supply

Bestell-Nr. / Order number	PSC / D	Ø A min.	Ø A max.	L	Wendeplattenhalter / Insert holder
PSC32-FBHS-DE-24	PSC 32 / 20	23.9	31.1	80	254.200.006 (CC.. 06 02 ..)
PSC32-FBHS-DE-31	PSC 32 / 25	30.9	40.1	90	254.250.006 (CC.. 06 02 ..)
PSC40-FBHS-DE-40	PSC 40 / 32	39.9	51.1	90	254.320.006 (CC.. 06 02 ..)
PSC50-FBHS-DE-51	PSC 50 / 42	50.9	67.1	90	254.420.006 (CC.. 06 02 ..)
PSC50-FBHS-DE-67	PSC 50 / 55	65.9	87.1	100	254.550.009 (CC.. 09 T3 ..)
PSC63-FBHS-DE-87	PSC 63 / 72	86.9	116.1	120	254.550.009 (CC.. 09 T3 ..)
PSC63-FBHS-DE-116	PSC 63 / 94	114.9	153.1	150	254.550.009 (CC.. 09 T3 ..)

- Wendeplattenhalter müssen separat bestellt werden
- Anzeigeeinheit muss separat bestellt werden siehe Seite 6 (266.028.077).

- insert holders must be ordered separately
- Display unit must be ordered separately see page 6 (266.028.077).



- für die Verwendung in Feinbohrköpfen der Serie 230, 251, 252 und 280

- for use in fine boring heads from serie 230, 251, 252 and 280



Bestell-Nr. / Order number	ø A min.	ø A max.	D	Wendeplatte / Insert	Feinbohrkopf / fine boring head
254.200.006	23.9	31.1	11	CC .. 06 02 ..	251/252.200.000
254.201.006	29.9	37.1	11	CC .. 06 02 ..	251/252.200.000
254.250.006	30.9	40.1	13	CC .. 06 02 ..	251/252.250.000
254.251.006	37.9	47.1	13	CC .. 06 02 ..	251/252.250.000
254.320.006	39.9	51.1	17	CC .. 06 02 ..	251/252.320.000
254.321.006	47.9	59.1	17	CC .. 06 02 ..	251/252.320.000
254.420.006	50.9	67.1	22	CC .. 06 02 ..	251/252.420.000
254.421.006	64.9	81.1	22	CC .. 06 02 ..	251/252.420.000
254.550.006	66.9	87.1	30	CC .. 06 02 ..	251/252.550.000
254.550.009	66.9	87.1	30	CC .. 09 T3 ..	251/252.550.000
254.551.006	84.9	105.1	30	CC .. 06 02 ..	251/252.550.000
254.551.009	84.9	105.1	30	CC .. 09 T3 ..	251/252.550.000
254.550.006	86.9	116.1	30	CC .. 06 02 ..	251/252.720.100
254.550.009	86.9	116.1	30	CC .. 09 T3 ..	251/252.720.100
254.551.006	104.9	134.1	30	CC .. 06 02 ..	251/252.720.100
254.551.009	104.9	134.1	30	CC .. 09 T3 ..	251/252.720.100
254.550.006	115.9	153.1	30	CC .. 06 02 ..	251/252.940.100
254.550.009	115.9	153.1	30	CC .. 09 T3 ..	251/252.940.100
254.551.006	133.9	171.1	30	CC .. 06 02 ..	251/252.940.100
254.551.009	133.9	171.1	30	CC .. 09 T3 ..	251/252.940.100
254.263.009	153.9	191.1	30	CC .. 09 T3 ..	251/252.940.100

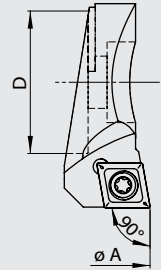

- für die Verwendung in Feinbohrköpfen der Serie 230, 251, 252 und 280

- for use in fine boring heads from serie 230, 251 252 and 280



Bestell-Nr. / Order number	ø A min.	ø A max.	D	Wendeplatte / Insert	Feinbohrkopf / fine boring head
254.205.006	23.9	31.1	11	CC .. 06 02 ..	251/252.200.000
254.255.006	30.9	40.1	13	CC .. 06 02 ..	251/252.250.000
254.325.006	39.9	51.1	17	CC .. 06 02 ..	251/252.320.000
254.425.006	50.9	67.1	22	CC .. 06 02 ..	251/252.420.000
254.555.009	66.9	87.1	30	CC .. 09 T3 ..	251/252.550.000
254.555.009	86.9	116.1	30	CC .. 09 T3 ..	251/252.720.100
254.555.009	115.9	153.1	30	CC .. 09 T3 ..	251/252.940.100

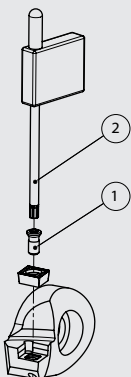
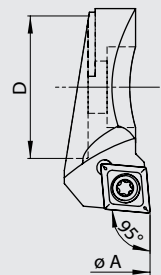

Ersatzteile / Zubehör

Spare parts / Accessories

254/282

Für Wendeplattenhalter For insert holder	Bestell-Nr. / Order number	Bestell-Nr. / Order number
	Torx-Schraube / Torx screw ^①	Torx-Schlüssel / Torx driver ^②
282.005.002	843.005.000	842.005.000
254.xxx.006	843.006.000	842.006.000
254.xxx.009	843.009.000	842.009.000

- für die Verwendung in Feinbohrköpfen der Serie 230, 251, 252 und 280

- for use in fine boring heads from serie 230, 251, 252 and 280



Bestell-Nr. / Order number	ø A min.	ø A max.	D	Wendepplatte / Insert	Feinbohrkopf / fine boring head
257.200.T07	23.9	31.1	11	TP .. 07 01 ..	251/252.200.000
257.201.T07	29.9	37.1	11	TP .. 07 01 ..	251/252.200.000
257.250.T07	30.9	40.1	13	TP .. 07 01 ..	251/252.250.000
257.251.T07	37.9	47.1	13	TP .. 07 01 ..	251/252.250.000
257.320.T07	39.9	51.1	17	TP .. 07 01 ..	251/252.320.000
257.321.T07	47.9	59.1	17	TP .. 07 01 ..	251/252.320.000
257.420.T07	50.9	67.1	22	TP .. 07 01 ..	251/252.420.000
257.421.T07	64.9	81.1	22	TP .. 07 01 ..	251/252.420.000
257.550.T11	66.9	87.1	30	TP .. 11 02 ..	251/252.550.000
257.551.T11	84.9	105.1	30	TP .. 11 02 ..	251/252.550.000
257.550.T11	86.9	116.1	30	TP .. 11 02 ..	251/252.720.100
257.551.T11	104.9	134.1	30	TP .. 11 02 ..	251/252.720.100
257.550.T11	115.9	153.1	30	TP .. 11 02 ..	251/252.940.100
257.551.T11	133.9	171.1	30	TP .. 11 02 ..	251/252.940.100
257.263.T11	153.9	191.1	30	TP .. 11 02 ..	251/252.940.100

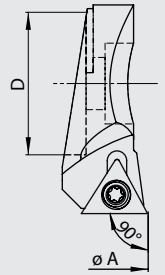

Wendepplattenhalter 93°

Insert holders 93°

- für die Verwendung in Feinbohrköpfen der Serie 230, 251, 252 und 280

- for use in fine boring heads from serie 230, 251, 252 and 280



Bestell-Nr. / Order number	ø A min.	ø A max.	D	Wendepplatte / Insert	Feinbohrkopf / fine boring head
256.200.T06	23.9	31.1	11	TB .. 06 01 ..	251/252.200.000
256.250.T09	30.9	40.1	13	TP .. 09 02 ..	251/252.250.000
256.320.T09	39.9	51.1	17	TP .. 09 02 ..	251/252.320.000
256.420.T11	50.9	67.1	22	TP .. 11 03 ..	251/252.420.000
256.550.T11	66.9	87.1	30	TP .. 11 03 ..	251/252.550.000
256.551.T11	84.9	105.1	30	TP .. 11 03 ..	251/252.550.000
256.550.T11	86.9	116.1	30	TP .. 11 03 ..	251/252.720.100
256.551.T11	104.9	134.1	30	TP .. 11 03 ..	251/252.720.100
256.550.T11	115.9	153.1	30	TP .. 11 03 ..	251/252.940.100
256.551.T11	133.9	171.1	30	TP .. 11 03 ..	251/252.940.100

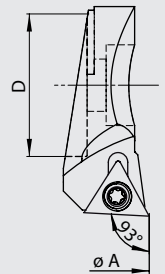

**Umkehradapter
für Rückwärtsbearbeitung**

**Reversal adapter
for reverse machining**

- für die Verwendung in Feinbohrköpfen der Serie 251 und 252
- damit können die Wendepaltenhalter der Serie 254 rückwärts montiert werden

- for use in fine boring heads from serie 251 and 252
- the insert holders from serie 254 will be fitted backwards on the adapter

Bestell-Nr. / Order number	ø A min.	ø A max.	D	L	L1	X	Feinbohrkopf / fine boring head
255.200.001	37	44	20	13.0	23.0	6.5	252.200.000
255.200.002	40	47	20	13.0	23.0	8.0	252.200.000
255.250.001	44	53	25	21.3	24.7	6.5	252.250.000
255.250.002	51	60	25	21.3	24.7	10.0	252.250.000
255.320.001	53	64	32	31.3	29.7	6.5	252.320.000
255.320.002	60	71	32	31.3	29.7	10.0	252.320.000
255.420.001	64	80	42	49.2	36.8	6.5	252.420.000
255.420.002	75	91	42	49.2	36.8	12.0	252.420.000
255.550.000	87	107	55	62.0	49	10.0	252.550.000
255.550.000	107	136	72	47.0	49	10.0	252.720.100
255.550.000	136	173	94	77.0	49	10.0	252.940.100

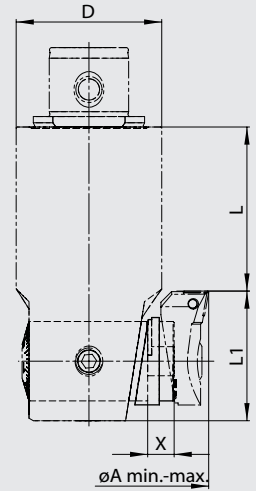

- Befestigungsschrauben werden mitgeliefert
- **Achtung: Linkslauf**

- fastening screws will be delivered with adapters
- **Caution: counterclockwise rotation**

**Einfahren
Enter into the bore**

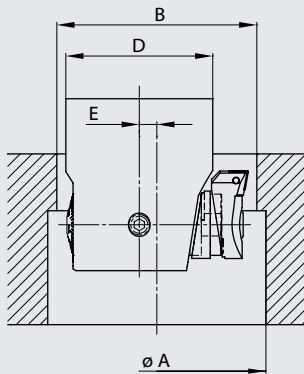

- Minstdurchmesser der Eintrittsbohrung

$$B = \frac{D + A}{2} + 1^*$$

- Mindestversatz zum Einfahren

$$E = \frac{A - B}{2} + 0.5^*$$

*Sicherheitsabstand

- minimum entry bore diameter

$$B = \frac{D + A}{2} + 1^*$$

- minimum off centre to enter into the bore

$$E = \frac{A - B}{2} + 0.5^*$$

*safety distance

**Rückwärtsbearbeitung
Back boring**

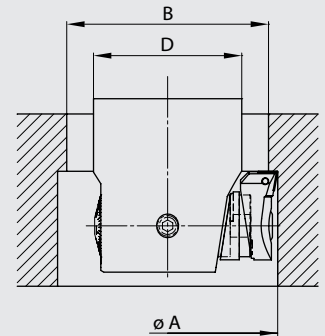

Ersatzteile / Zubehör

Spare parts / Accessories

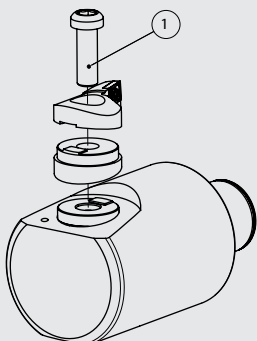

Für Umkehradapter For reversal adapter	Bestell-Nr. / Order number	Befestigungsschraube / Fastening screw ①
255.200.001	880.252.201	
255.200.002	880.252.202	
255.250.001	880.252.251	
255.250.002	880.252.252	
255.320.001	880.252.321	
255.320.002	880.252.322	
255.420.001	880.252.421	
255.420.002	880.252.422	
255.550.000	880.252.551	

- Durchmessereinstellung mit geringstem Umkehrspiel
- Zustellgenauigkeit von 0.01mm im Durchmesser
- mit Innenkühlung
- diametrical adjustment with maximal reduced reversal backlash
- 0.01mm diametrical adjustment
- with inner coolant supply

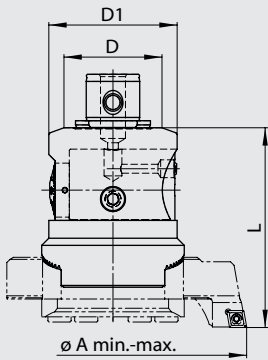

Bestell-Nr. / Order number	System ø D	D1	ø A min.	ø A max.	L
256.550.000	55	72	86	402	112

- Wendeplattenhalter der Serie 258 müssen separat bestellt werden
- insert holders from serie 258 must be ordered separately



Wendeplattenhalter inkl. Druckplatte und Abstützung

Insert holders incl. clamp plate and support block

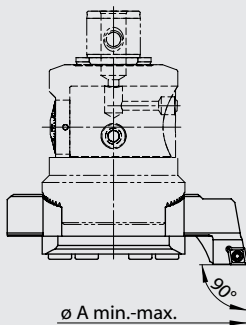

Bestell-Nr. / Order number	ø A min.	ø A max.	Wendeplatte / Insert
258.550.109	86	138	CC.. 09 T3 ..
258.550.112	86	138	CC.. 12 04 ..
258.550.209	136	220	CC.. 09 T3 ..
258.550.212	136	220	CC.. 12 04 ..
258.550.309	188	302	CC.. 09 T3 ..
258.550.409	242	402	CC.. 09 T3 ..



Ersatzteile / Zubehör

Spare parts / Accessories

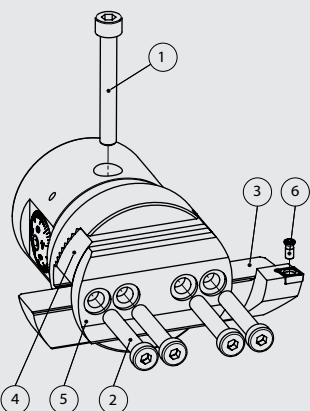

Für Feinbohrkopf / For fine boring head	Bestell-Nr. / Order number	Bestell-Nr. / Order number			
	Klemmschraube / Clamping screw ①	Befestigungsschraube / Fastening screw ②			
256.550.000	850.256.550	850.144.550			
Für Wendeplattenhaltersatz / For insert holder set	Bestell-Nr. / Order number	Bestell-Nr. / Order number	Bestell-Nr. / Order number	Bestell-Nr. / Order number	Bestell-Nr. / Order number
	Wendeplattenhalter / Insert holder ③	Abstützung / Support block ④	Druckplatte / Clamp plate ⑤	Torx-Schraube / Torx screw ⑥	Torx-Schlüssel / Torx driver
258.550.109	190.550.109	885.190.109	884.190.109	843.009.000	842.009.000
258.550.112	190.550.112	885.190.109	884.190.109	843.012.000	842.012.000
258.550.209	190.550.209	885.190.209	884.190.209	843.009.000	842.009.000
258.550.212	190.550.212	885.190.209	884.190.209	843.012.000	842.012.000
258.550.309	190.550.309	885.190.209	884.190.209	843.009.000	842.009.000
258.550.409	190.550.409	885.190.209	884.190.209	843.009.000	842.009.000

Zweischneiderköpfe zum Einschrauben

Twin cutter heads with thread connection

- mit Innenkühlung

- with inner coolant supply



Bestell-Nr. / Order number	$\varnothing A$ min.	$\varnothing A$ max.	d	L	Wendepplatten- halter / Insert holder
140.020.041	23.5	30.5	20	41	162.200.006
					182.200.006
					166.200.006
					167.200.006
140.025.045	29.5	40.1	25	45	162.250.006
					182.250.006
					166.250.006
					167.250.006
140.032.051	39.5	50.5	32	51	162.320.009
					182.320.009
					166.320.009
					167.320.009

- Wendepplattenhalter müssen separat bestellt werden

- insert holders must be ordered separately

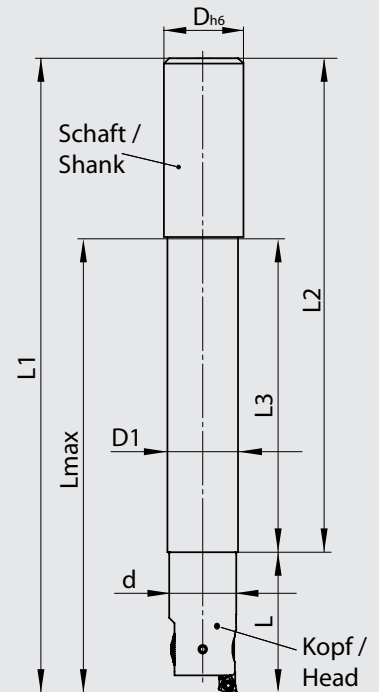

Schwingungsgedämpfte Vollhartmetallschäfte

Damped solid carbide shanks

- Produktivitätsgewinn dank der unterdrückten Schwingungen können die Schnittdaten beträchtlich erhöht werden
- Verbesserte Oberflächengüte
- Verbesserte Prozesssicherheit
- Verbesserte Spanabfuhr
- Reduzierte Kosten pro Bauteil
- Für Bohrungstiefen bis 12xD

- productivity improvement: thanks to reduced vibrations, the cutting conditions can be improved remarkable
- better surface quality
- improved process stability
- better chip evacuation
- reduced cost per part
- for boring length up to 12xD



Bestell-Nr. / Order number	D	D1	L max	L1	L2	L3	für Einschraub- kopf / for screw- able head
276.025.170	25	23	146	211	170	105	280/140.020.041
276.025.220	25	23	196	261	220	155	280/140.020.041
276.025.265	25	23	241	306	265	200	280/140.020.041
276.032.220	32	29	200	265	220	155	280/140.025.045
276.032.260	32	29	240	305	260	195	280/140.025.045
276.032.310	32	29	290	355	310	245	280/140.025.045
276.032.217	32	32	203	268	217	152	280/140.032.051
276.032.287	32	32	273	338	287	222	280/140.032.051
276.032.357	32	32	343	408	357	292	280/140.032.051



Zweischneiderköpfe
Ø23.5-40.1

Twin cutter boring heads
Ø23.5-40.1

ECO LINE Uxx_Z

- mit Innenkühlung

- with inner coolant supply

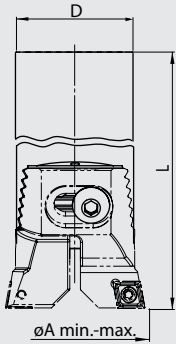

Bestell-Nr. / Order number	ø A min.	ø A max.	Ø D/ System	L	Wendeplattenhalter / Insert holder
U20_Z20.K23.150	23.5	31.1	20	150	162.200.006 (CC.. 06 02 ..)
U25_Z25.K23.170	29.5	40.1	25	170	162.250.006 (CC.. 06 02 ..)

- Werkzeug in einem Spannzangen- oder Hydrodehnfutter spannen.
- **inklusive Wendeplattenhalter**

- Clamp tool in a collet or hydraulic chuck.
- **insert holder included**



ECO LINE

Zweischneiderköpfe
Ø65.5-87.1

Twin cutter boring heads
Ø65.5-87.1

ECO LINE Exx_Z

- mit Innenkühlung

- with inner coolant supply

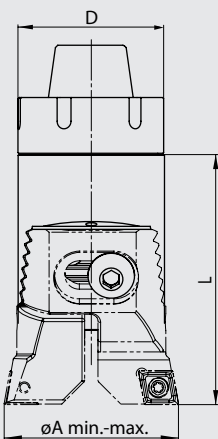

Bestell-Nr. / Order number	ø A min.	ø A max.	Ø D/ System	L	Wendeplattenhalter / Insert holder
E25_Z32.K23.065	39.5	50.1	32 / ER25	65	162.320.009 (CC.. 09 T3 ..)
E32_Z42.K23.075	49.5	67.1	42 / ER32	75	162.420.009 (CC.. 09 T3 ..)
E40_Z55.K23.085	65.5	87.1	55 / ER40	85	162.550.012 (CC.. 12 04 ..)

- Werkzeug in einem Spannzangenfutter spannen.
- **inklusive Wendeplattenhalter**

- Clamp tool in a collet chuck.
- **insert holder included**



ECO LINE

- mit Innenkühlung

- with inner coolant supply

Bestell-Nr. / Order number	System ø D	ø A min.	ø A max.	L	Wendeplattenhalter / Insert holder
142.200.000	20	23.5	30.5	40	162.200.006
					182.200.006
					166.200.006
					167.200.006
142.250.000	25	29.5	40.1	50	162.250.006
					182.250.006
					166.250.006
					167.250.006
142.320.000	32	39.5	50.5	65	162.320.009
					182.320.009
					166.320.009
					167.320.009
142.420.000	42	49.5	66.5	90	162.420.009
					182.420.009
					166.420.009
					167.420.009
142.550.000	55	65.5	87.5	115	162.550.012/112
					182.550.012/112
					166.550.012
					167.550.012
142.720.100	72	86.5	115.5	100	162.720.016/112
					182.720.016/112
					166.720.012
					167.720.012
142.940.100	94	114.5	153	130	162.940.016/112
					182.940.016
					166.940.012
					167.940.012

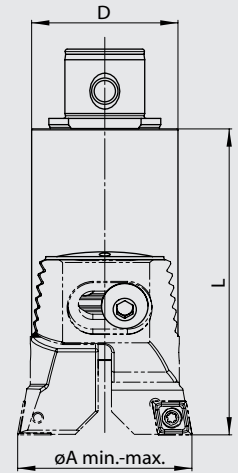

- Wendeplattenhalter müssen separat bestellt werden

- insert holders must be ordered separately

- für die Verwendung in Zweischneiderköpfen der Serie 142

- for use in twin cutter boring heads from serie 142

Bestell-Nr. / Order number	ø A min.	ø A max.	Wendeplatte / Insert	Zweischeiderkopf / twin cutter boring head
162.200.006	23.5	30.5	CC ..06 02 ..	142.200.000
162.250.006	29.5	40.1	CC ..06 02 ..	142.250.000
162.320.009	39.5	50.5	CC ..09 T3 ..	142.320.000
162.420.009	49.5	66.5	CC ..09 T3 ..	142.420.000
162.550.112	65.5	87.5	CC ..12 04 ..	142.550.000
162.550.012	65.5	87.5	CN ..12 04 ..	142.550.000
162.720.112	86.5	115.5	CC ..12 04 ..	142.720.100
162.720.016	86.5	115.5	CN ..16 06 ..	142.720.100
162.940.112	114.5	153.0	CC ..12 04 ..	142.940.100
162.940.016	114.5	153.0	CN ..16 06 ..	142.940.100

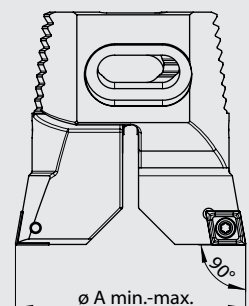

- Wendeplattenhalter werden paarweise geliefert

- insert holders will be supplied in pairs

Synchro-Wendeplattenhalter 90° Synchronised insert holders 90°

166

- für die Verwendung in Zweischneiderköpfen der Serie 142
- mit der Synchrospindel können beide Wendeplattenhalter gleichzeitig symmetrisch eingestellt werden
- for use in twin cutter boring heads from serie 142
- with synchro spindle both insert holders can be adjusted synchronously and symmetrically

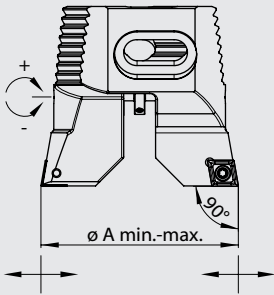

Bestell-Nr. / Order number	ø A min.	ø A max.	Wendeplatte / Insert	Zweischneiderkopf / twin cutter boring head
166.200.006	23.5	30.5	CC .06 02 ..	142.200.000
166.250.006	29.5	40.1	CC .06 02 ..	142.250.000
166.320.009	39.5	50.5	CC .09 T3 ..	142.320.000
166.420.009	49.5	66.5	CC .09 T3 ..	142.420.000
166.550.012	65.5	87.5	CC .12 04 ..	142.550.000
166.720.012	86.5	115.5	CC .12 04 ..	142.720.100
166.940.012	114.5	153	CC .12 04 ..	142.940.100



- Wendeplattenhalter werden paarweise geliefert
- insert holders will be supplied in pairs

Wendeplattenhalter 70°

Insert holders 70°

182

- für die Verwendung in Zweischneiderköpfen der Serie 142
- for use in twin cutter boring heads from serie 142

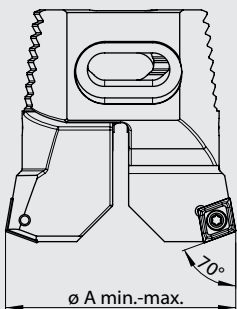

Bestell-Nr. / Order number	ø A min.	ø A max.	Wendeplatte / Insert	Zweischneiderkopf / twin cutter boring head
182.200.006	23.5	30.5	CC .06 02 ..	142.200.000
182.250.006	29.5	40.1	CC .06 02 ..	142.250.000
182.320.009	39.5	50.5	CC .09 T3 ..	142.320.000
182.420.009	49.5	66.5	CC .09 T3 ..	142.420.000
182.550.112	65.5	87.5	CC .12 04 ..	142.550.000
182.550.012	65.5	87.5	CN .12 04 ..	142.550.000
182.720.112	86.5	115.5	CC .12 04 ..	142.720.100
182.720.016	86.5	115.5	CN .16 06 ..	142.720.100
182.940.016	114.5	153	CN .16 06 ..	142.940.100



- Wendeplattenhalter werden paarweise geliefert
- insert holders will be supplied in pairs

Wendeplattenhalter 90° axial 0.4mm zurückgesetzt

Insert holders 90° axial 0.4mm staggered

167

- für die Verwendung in Zweischneiderköpfen der Serie 142
- zur Schnittaufteilung bei grosser Spantiefe
- for use in twin cutter boring heads from serie 142
- for divided cut

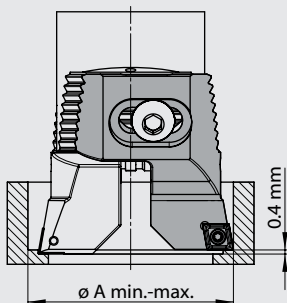

Bestell-Nr. / Order number	ø A min.	ø A max.	Wendeplatte / Insert	Zweischneiderkopf / twin cutter boring head
167.200.006	23.5	30.5	CC .06 02 ..	142.200.000
167.250.006	29.5	40.1	CC .06 02 ..	142.250.000
167.320.009	39.5	50.5	CC .09 T3 ..	142.320.000
167.420.009	49.5	66.5	CC .09 T3 ..	142.420.000
167.550.012	65.5	87.5	CC .12 04 ..	142.550.000
167.720.012	86.5	115.5	CC .12 04 ..	142.720.100
167.940.012	114.5	153	CC .12 04 ..	142.940.100



- Wendeplattenhalter werden paarweise geliefert
- insert holders will be supplied in pairs

Schrupp-/ Schlicht Zweischneiden Ausdrehkopf

Roughing-/Finishing twin cutter boring head

- Schruppen und Schlichten in einem Arbeitsgang
- Zustellgenauigkeit von 0.01mm im Durchmesser
- Schlichtschneide axial 0.4mm zurückgesetzt
- höchste Stabilität durch Kerbverzahnung
- mit Innenkühlung

- Roughing and finishing in one step
- Setting accuracy 0.01mm in diameter
- Fine boring cutting edge axial 0.4mm staggered
- highest stability because of the tooth profile
- with inner coolant supply



Bestell-Nr. / Order number	System ø D	ø A min.	ø A max.	L	Wendeplattenhalter / Insert holder
145.250.000	25	29.5	40.1	55	168.250.006
145.320.000	32	39.5	50.5	65	168.320.009
145.420.000	42	49.5	66.5	90	168.420.009
145.550.000	55	65.5	87.5	115	168.550.012
145.720.000	72	86.5	115.5	125	168.720.012

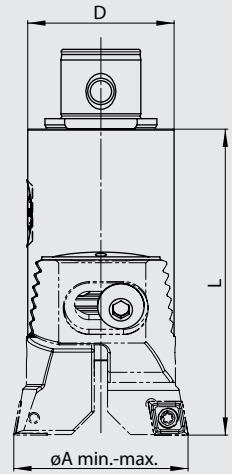

- Wendeplattenhalter müssen separat bestellt werden

- insert holders must be ordered separately

Schrupp-/ Schlicht Wendeplattenhalterpaar 90°

Roughing-/Finishing insert holder pair 90°

- für die Verwendung in Zweischneiderköpfen der Serie xxx

- for use in twin cutter boring heads from serie xxx



Bestell-Nr. / Order number	ø A min.	ø A max.	Wendeplatte / Insert	Zweischneiderkopf / twin cutter boring head
168.250.006	29.5	40.1	CC . .06 02 . .	145.250.000
168.320.009	39.5	50.5	CC . .09 T3 . .	145.320.000
168.420.009	49.5	66.5	CC . .09 T3 . .	145.420.000
168.550.012	65.5	87.5	CC . .12 04 . .	145.550.000
168.720.012	86.5	115.5	CC . .12 04 . .	145.720.000

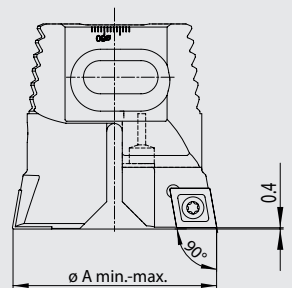

- Wendeplattenhalter werden paarweise geliefert

- insert holders will be supplied in pairs

Ersatzteile / Zubehör

Spare parts / Accessories

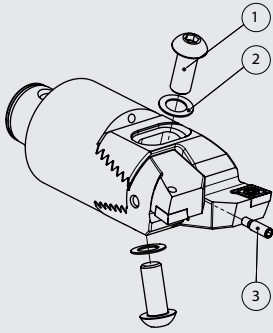

Für Zweischneiderkopf	Bestell-Nr. / Order number	Bestell-Nr. / Order number	Bestell-Nr. / Order number
For twin cutter boring head	Befestigungsschraube / Fastening screw ①	Federring / Spring washer ②	Anschlag / Stopper ③
142.200.000	840.142.200	841.142.200	841.342.200
142.250.000	840.142.250	841.142.250	841.342.200
142.320.000	840.142.320	841.142.320	841.342.200
142.420.000	840.142.420	841.142.420	841.342.420
142.550.000	840.142.550	841.142.550	841.342.420
142.720.100	840.142.720	841.142.720	841.342.420
142.940.100	840.142.940	841.142.940	841.342.420

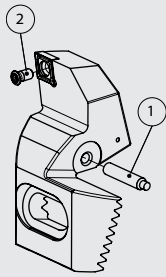

Ersatzteile / Zubehör

Spare parts / Accessories

Für Wendeplattenhalter	Bestell-Nr. / Order number	Bestell-Nr. / Order number	Bestell-Nr. / Order number
For insert holder	Einstellschraube / Adjustment screw ①	Torx-Schraube / Torx screw ②	Torx-Schlüssel / Torx driver
162/167/182.200.006	848.200.407	843.006.000	842.006.000
162/167/182.250.006	848.250.409	843.006.000	842.006.000
162/167/182.320.009	848.320.413	843.009.000	842.009.000
162/167/182.420.009	848.420.614	843.009.000	842.009.000
162/167/182.550.xxx	848.550.620	843.012.000	842.012.000
162/167/182.720.xxx	848.720.000	843.012.000	842.012.000
162/167/182.940.xxx	848.940.640	843.012.000	842.012.000

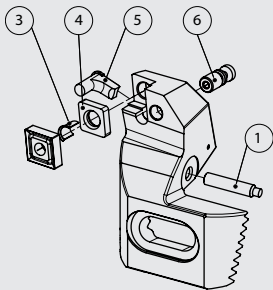

Für Wendeplattenhalter	Bestell-Nr. / Order number	Bestell-Nr. / Order number	Bestell-Nr. / Order number	Bestell-Nr. / Order number
For insert holder	Rohrstift / Hollow pin ③	Zwischenlage / Tip pad ④	Kniehebel / Lever ⑤	Schraube zu Kniehebel / Lever screw ⑥
162/182.550.012	844.012.000	845.012.000	846.012.000	847.012.000
162/182.720.016	844.016.000	845.016.000	846.016.000	847.016.000
162/182.940.016	844.016.000	845.016.000	846.016.000	847.016.000

Ersatzteile / Zubehör

Spare parts / Accessories

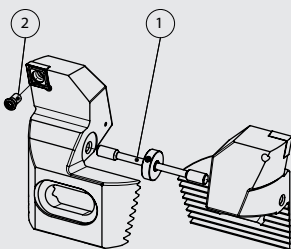

Für Wendeplattenhalter	Bestell-Nr. / Order number	Bestell-Nr. / Order number	Bestell-Nr. / Order number
For insert holder	Einstellschraube / Adjustment screw ①	Torx-Schraube / Torx screw ②	Torx-Schlüssel / Torx driver
166.200.006	848.200.005	843.006.000	842.006.000
166.250.006	848.250.005	843.006.000	842.006.000
166.320.009	848.320.005	843.009.000	842.009.000
166.420.009	848.420.005	843.009.000	842.009.000
166.550.012	848.550.005	843.012.000	842.012.000
166.720.012	848.720.005	843.012.000	842.012.000
166.940.012	848.940.005	843.012.000	842.012.000

- Einfache, kostengünstige Ausführung
- Brücke wird auf einen Fräsdorn Ø32 gespannt
- Modular aufgebaut und verlängerbar für grosse Zapfenlängen
- mit innerer Kühlmittelzuführung

- simple and cost effective solution
- bridge is assembled on a milling arbor Ø32
- modular construction, extendable for long work pieces
- with inner coolant supply

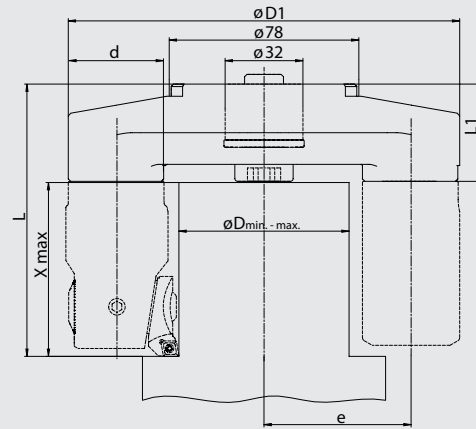

Bestell-Nr. / Order number	ø D min.	ø D max.	d	e	D1	L1	X* max	L*
222.320.099	15.9	27.1	32	33.5	99	40	65.0 (105.0)	105.0 (145.0)
222.320.110	26.9	38.1	32	39.0	110	40	65.0 (105.0)	105.0 (145.0)
222.420.145	37.9	54.1	42	52.5	145	40	90.0	130.0
222.420.161	53.9	70.1	42	60.5	161	40	90.0	130.0
222.550.207	69.9	90.1	55	78.5	207	45	115.0	160.0
222.550.227	89.9	110.1	55	88.5	227	45	115.0	160.0

- *) Die Werte in Klammern zeigen die Werkzeuglänge und max. Zapfenlänge unter Verwendung der entsprechenden Verlängerungen.
- Gegengewicht und Spannschraube im Lieferumfang enthalten. Feinbohrkopf oder Zweischneiderkopf muss separat bestellt werden

- *) The values in brackets indicate the tool length and the max. pin length with the use of the corresponding extensions.
- Counter weight and clamping screw included. Fine boring head or twin cutter must be ordered separately.

Werkzeugauswahl

Tool selection



- Schlichten

- Finishing

Werkzeughalter / Toolholder	Ausdrehkopf / Boring head	Plattenhalter / Insert holder	ø D min.	ø D max.	Gegengewicht / Counter weight
222.320.099	252.320.000	254.320.006	15.9	27.1	233.320.057
222.320.110	252.320.000	254.320.006	26.9	38.1	233.320.057
222.420.145	252.420.000	254.420.006	37.9	54.1	233.420.082
222.420.161	252.420.000	254.420.006	53.9	70.1	233.420.082
222.550.207	252.550.000	254.550.009	69.9	90.1	233.550.105
222.550.227	252.550.000	254.550.009	89.9	110.1	233.550.105

Werkzeugauswahl

Tool selection



- Schruppen

- Roughing

Werkzeughalter / Toolholder	Schruppkopf / Roughing head	Plattenhalter / Insert holder	ø D min.	ø D max.
222.320.099	142.320.000	162.320.009	15.9	27.1
222.320.110	142.320.000	162.320.009	26.9	38.1
222.420.145	142.420.000	162.420.009	37.9	54.1
222.420.161	142.420.000	162.420.009	53.9	70.1
222.550.207	142.550.000	162.550.112	69.9	90.1
222.550.227	142.550.000	162.550.112	89.9	110.1

Zapfenbearbeitung

Pin turning

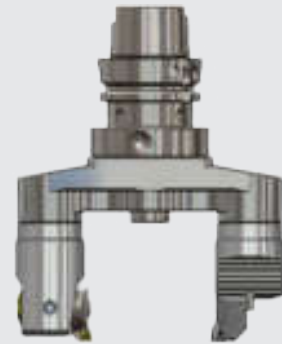
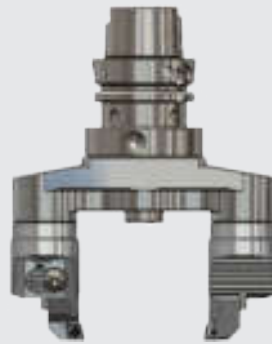
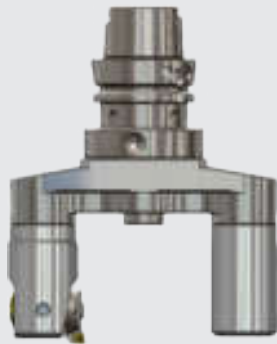

- **Achtung:** Spindel linksdrehend!
Vc max. 450 m/min

- **Attention:** Counter clockwise spindle rotation
Vc max. 450 m/min

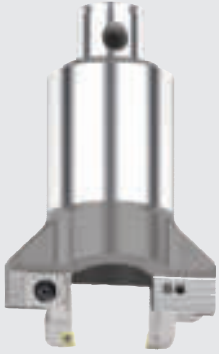

Bestell-Nr. / Order number	System ø D	D1	ø A min.	ø A max.	L	L1	Wendeplattenhalter / Insert holder
141.420.000	42	70	3.0	22.5	90	82	162.200.006 182.200.006
141.550.000	55	91	17.5	37.5	120	110	162.250.006 182.250.006
141.720.000	72	128	21.5	50.5	165	153	162.320.009 182.320.009
141.940.000	94	168	36.5	70.5	230	214	162.420.009 182.420.009

• Achtung: Linkslauf

• Wendeplattenhalter müssen separat bestellt werden

• Caution: counterclockwise rotation

• insert holders must be ordered separately

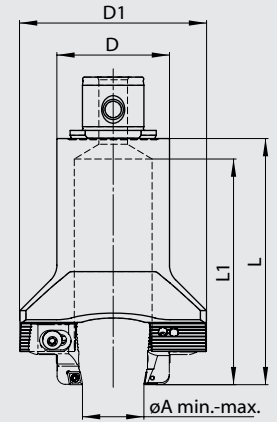

Ersatzteile / Zubehör

Spare parts / Accessories

141

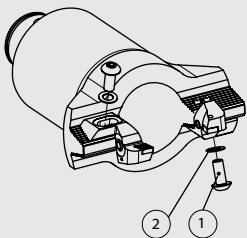

Für Zweischneider- überdrehkopf	Bestell-Nr. / Order number	Bestell-Nr. / Order number
For twin cutter pin turning head	Befestigungsschraube / Fastening screw ①	Federring / Spring washer ②
141.420.000	840.142.200	841.142.200
141.550.000	840.142.250	841.142.250
141.720.000	840.142.320	841.142.320
141.940.000	840.142.420	841.142.420

• mit Innenkühlung

• with inner coolant supply

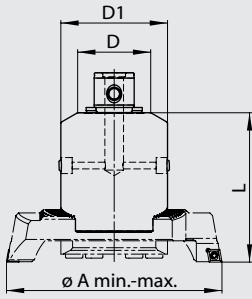

Bestell-Nr. / Order number	System øD	D1	ø A min.	ø A max.	L
146.550.000	55	80	86	402	112

• Wendeplattenhalter der Serie 148 müs-
sen separat bestellt werden

• insert holders from serie 148 must be
ordered separately



Wendeplattenhalterpaare
inkl. Druckplatte

Insert holder pairs
incl. clamp plate

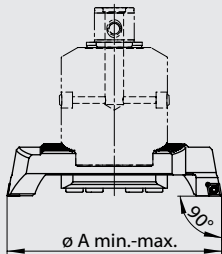

Bestell-Nr. / Order number	ø A min.	ø A max.	Wendeplatte / Insert
148.550.109	86	138	CC .. 09 T3 ..
148.550.112	86	138	CC .. 12 04 ..
148.550.209	136	220	CC .. 09 T3 ..
148.550.212	136	220	CC .. 12 04 ..
148.550.309	188	302	CC .. 09 T3 ..
148.550.409	242	402	CC .. 09 T3 ..



Ersatzteile / Zubehör

Spare parts / Accessories

Für Zweischneiderkopf For twin cutter boring head	Bestell-Nr. / Order number	Befestigungsschraube / Fastening screw			
146.550.000	850.144.550	①			
Für Wendeplatten- haltersatz For insert holder set	Bestell-Nr. / Order number	Bestell-Nr. / Order number	Bestell-Nr. / Order number	Bestell-Nr. / Order number	Bestell-Nr. / Order number
	Wendeplattenhal- ter / Insert holder	Druckplatte / Clamp plate	Torx-Schraube / Torx screw	Torx-Schlüssel / Torx driver	
148.550.109	190.550.109	884.190.109	843.009.000	842.009.000	
148.550.112	190.550.112	884.190.109	843.012.000	842.012.000	
148.550.209	190.550.209	884.190.209	843.009.000	842.009.000	
148.550.212	190.550.212	884.190.209	843.012.000	842.012.000	
148.550.309	190.550.309	884.190.209	843.009.000	842.009.000	
148.550.409	190.550.409	884.190.209	843.009.000	842.009.000	

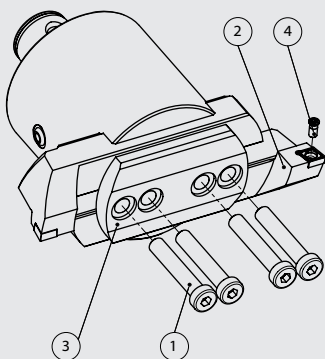

- Durchmessereinstellung mit geringstem Umkehrspiel
- Zustellgenauigkeit von 0.01mm im Durchmesser
- mit Innenkühlung
- diameter setting with minimal reversal backlash
- 0.01mm diametrical adjustment
- with inner coolant supply



Bestell-Nr. / Order number	Ø D/ System	Ø A min.	Ø A max.	L	Feinbohraufsatz / Fine bore adapter
D32_F01.085.098	78 / D32	85.5	140.1	98	F01_WCA.B11.050 (CC.. 06 02 ..)
D32_F02.139.098	78 / D32	139.5	220.1	98	F02_WCA.B11.050 (CC.. 06 02 ..)
D32_F02.219.098	78 / D32	219.5	310.1	98	F02_WCA.B11.050 (CC.. 06 02 ..)
D40_F02.309.108	88 / D40	309.5	395.1	108	F02_WCA.B11.050 (CC.. 06 02 ..)
D40_F02.394.108	88 / D40	394.5	480.1	108	F02_WCA.B11.050 (CC.. 06 02 ..)
D60_F02.479.118	128 / D60	479.5	565.1	118	F02_WCA.B11.050 (CC.. 06 02 ..)
D60_F02.564.118	128 / D60	564.5	650.1	118	F02_WCA.B11.050 (CC.. 06 02 ..)

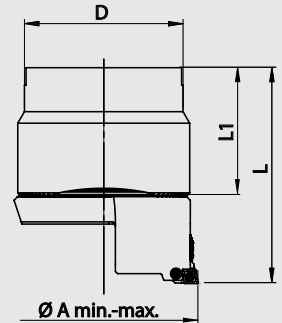

- Werkzeug in einer Fräsdorn- oder Messerkopfaufnahme spannen.
- **inklusive Feinbohraufsatz (F01/F02)**
- Clamp tool in a shell mill holder.
- **Fine boring adapter included (F01/ F02)**

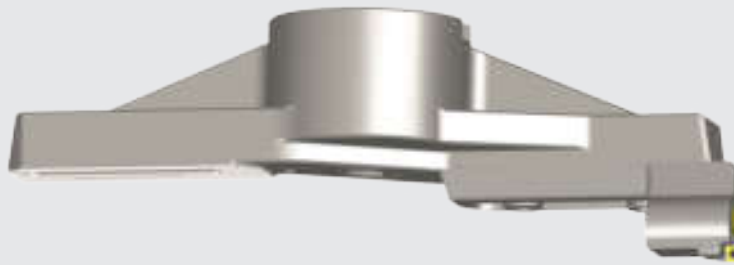

- mit Innenkühlung
- with inner coolant supply

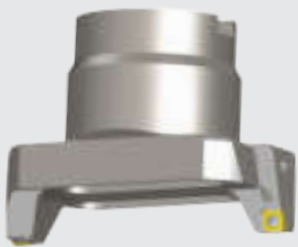

Bestell-Nr. / Order number	Ø D/ System	Ø A min.	Ø A max.	L	Wendeplattenhalter / Insert holder
D32_Z01.085.098	78 / D32	85.5	140.1	98	Z01_WCC.B11.050 (CC.. 12 04 ..)
D32_Z02.139.098	78 / D32	139.5	220.1	98	Z02_WCC.B11.050 (CC.. 12 04 ..)
D32_Z02.219.098	78 / D32	219.5	310.1	98	Z02_WCC.B11.050 (CC.. 12 04 ..)
D40_Z02.309.108	88 / D40	309.5	395.1	108	Z02_WCC.B11.050 (CC.. 12 04 ..)
D40_Z02.394.108	88 / D40	394.5	480.1	108	Z02_WCC.B11.050 (CC.. 12 04 ..)
D60_Z02.479.118	128 / D60	479.5	565.1	118	Z02_WCC.B11.050 (CC.. 12 04 ..)
D60_Z02.564.118	128 / D60	564.5	650.1	118	Z02_WCC.B11.050 (CC.. 12 04 ..)

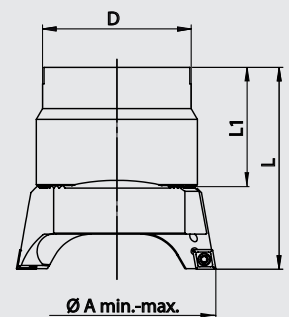

- Werkzeug in einer Fräsdorn- oder Messerkopfaufnahme spannen.
- **inklusive Wendeplattenhalter (Z01/Z02)**
- Clamp tool in a shell mill holder.
- **insert holder included (Z01/Z02)**

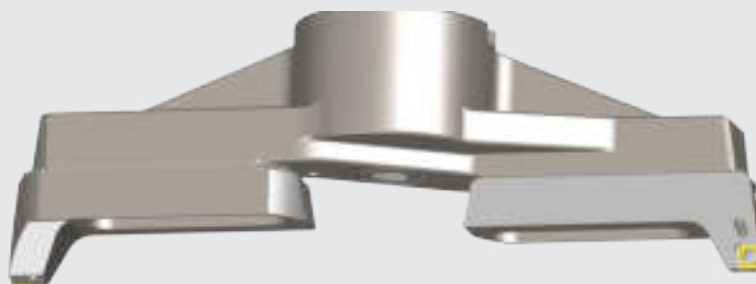

- für die Verwendung auf Aufnahme-
dorn ø60 / ø129 DIN 6357
- Basis aus Aluminium
- fragen Sie uns an für optimierte Kom-
plettlösungen

- for use on holding arbor ø60 / ø129
- basis made of aluminium
- please get in touch with us for
customized solutions

Basis / Basis Bestell-Nr. / Order number	Schieber / Slider Bestell-Nr. / Order number	D	L	Ausrehdurchmesser / Boring diameter
223.060.063	224.310.048	630	128	650 – 1105
223.060.108	224.360.048	1080	128	1100 - 1655
223.060.163	224.360.048	1630	128	1650 – 2205

- Schieber müssen separat bestellt wer-
den und werden paarweise geliefert

- sliders must be ordered separatly
and will be supplied in pairs

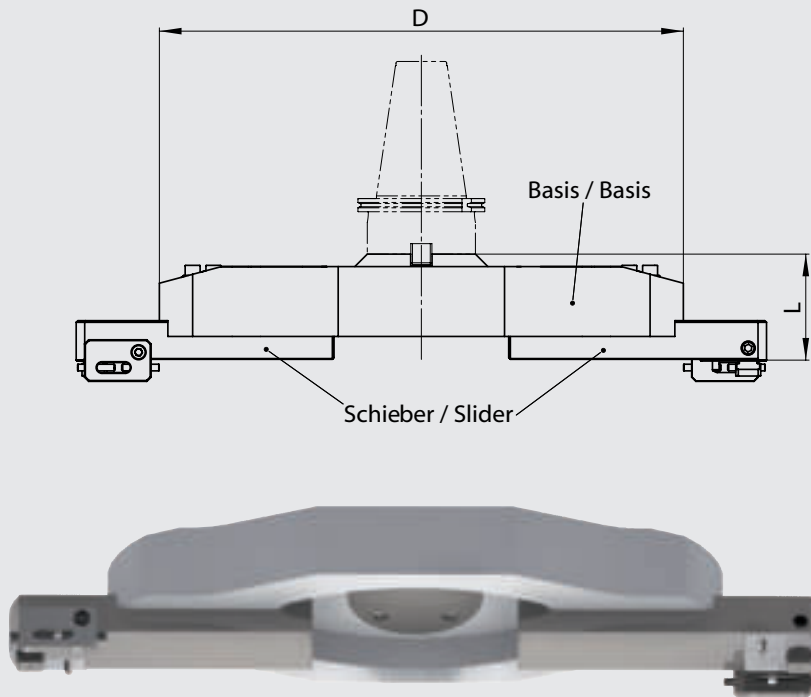

Aufnahmedorn für
Verlängerungskonsolen

Holding arbor for
extension bridges

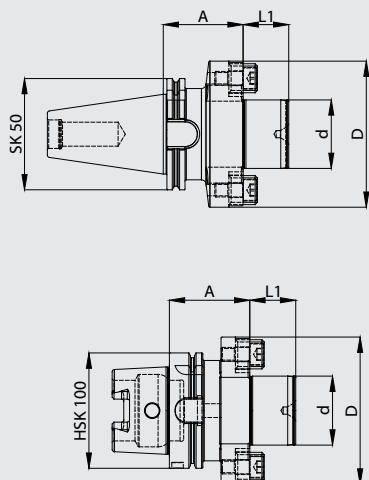

Bestell-Nr. / Order number	SK	d	A	L1	D
214.515.070	SK 50	60	70	40	128
Bestell-Nr. / Order number	BT	d	A	L1	D
214.512.080	BT 50	60	80	40	128
Bestell-Nr. / Order number	HSK-A	d	A	L1	D
214.100.070	HSK-A 100	60	70	40	128



Aufnahmen mit Konsole

Master shanks with bridge adapter



• DIN 69871 A/D

Bestell-Nr. / Order number	ISO	D	A
210.415.000	40	130	69.1
210.515.000	50	130	69.1

• DIN 69871 A/D

• MAS BT 403

Bestell-Nr. / Order number	BT	D	A
210.412.000	40	130	77
210.512.000	50	130	88

• MAS BT 403

• DIN 69893 HSK A

Bestell-Nr. / Order number	HSK A	D	A
210.063.000	63	130	75
210.100.000	100	130	75

• DIN 69893 HSK A

• Kühlmittelset muss separat bestellt werden 920.028.015

• cooling set must be ordered separately 920.028.015

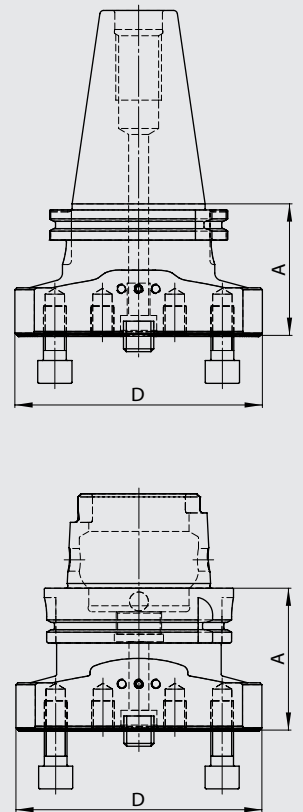

Zwischenkonsolen

Bridge adapters



Bestell-Nr. / Order number	System ø D	D1	L
212.720.000	72	130	55
212.940.000	94	130	55

• Kühlmittelset muss separat bestellt werden 920.028.015

• cooling set must be ordered separately 920.028.015

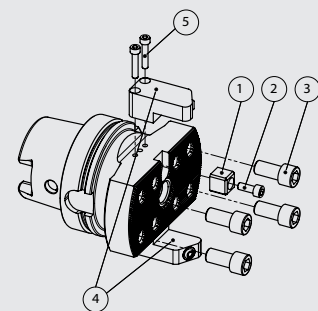
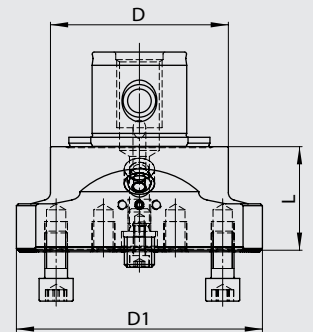

Ersatzteile / Zubehör

Spare parts / Accessories

210/212

Für Konsole / For bridge adapter	Bestell-Nr. / Order number	Bestell-Nr. / Order number	Bestell-Nr. / Order number
	Mitnehmerstein / Drive lug ①	Schraube / Screw ②	Befestigungsschraube / Fastening screw ③
210 / 212	810.212.362	811.210.212	812.210.212
Für Konsole / For bridge adapter	Bestell-Nr. / Order number	Bestell-Nr. / Order number	
	Kühlmittelset / Cooling set ④	Befestigungsschraube / Fastening screw ⑤	
210 / 212	920.028.015	920.029.025	

Verlängerungskonsolen
ø150-655

Extension bridges
ø150-655

- für die Verwendung auf Konsolen der Serie 210 und 212

- for use on bridge adapters from serie 210 and 212

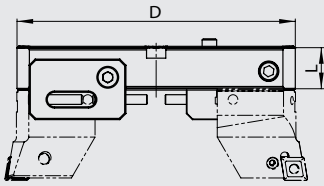

Bestell-Nr. / Order number	D	L	Ausdrehdurchmesser / Boring diameter
221.130.000	130	30	150 – 205
221.180.000	180	30	200 – 255
221.230.000	230	35	250 – 305
221.280.000	280	35	300 – 355
221.330.000	330	40	350 – 405
221.380.000	380	40	400 – 455
221.430.000	430	40	450 – 505
221.480.000	480	40	500 – 555
221.530.000	530	50	550 – 605
221.580.000	580	50	600 – 655



- Verlängerungskonsolen werden mit Einstellplatte geliefert

- extension bridges will be supplied with adjustment plate

Einstellplatte zum Überdrehen Adjustment plate for pin turning

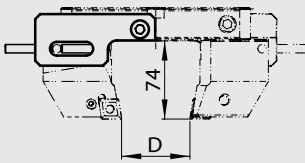

Einstellplatte / Adjustment plate Bestell-Nr. / Order number	Für Verlängerungskonsole / For extensions bridge	D
878.221.000	221.180.000	10 - 65
878.221.000	221.230.000	60 - 115
878.221.000	221.280.000	110 - 165
878.221.000	221.330.000	160 - 215
878.221.000	221.380.000	210 - 265
878.221.000	221.430.000	260 - 315
878.221.000	221.480.000	310 - 365
878.221.000	221.530.000	360 - 415
878.221.000	221.580.000	410 - 465



- Einstellplatten werden paarweise geliefert

- adjustment plates will be supplied in pairs

Ersatzteile / Zubehör

Spare parts / Accessories

221/223/224

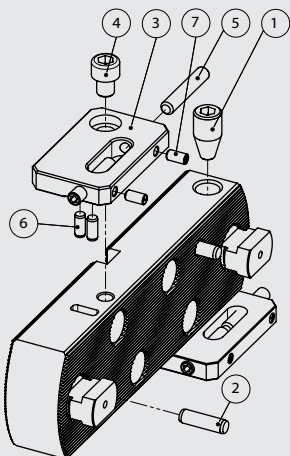

Für Verlängerungskonsole / Schieber For extension bridge / Slider	Bestell-Nr. / Order number	Bestell-Nr. / Order number	Bestell-Nr. / Order number	Bestell-Nr. / Order number
221 / 224	860.220.000	864.220.000		877.221.112
Für Verlängerungskonsole / Schieber For extension bridge / Slider	Bestell-Nr. / Order number	Bestell-Nr. / Order number	Bestell-Nr. / Order number	Bestell-Nr. / Order number
221.130/230.000	877.221.000	877.221.012	877.221.045	877.221.014
221.180/280-580.000	877.221.000	877.221.018	877.221.045	877.221.014
224.xxx.048	877.221.000	877.221.018	877.221.045	877.221.014
Für Basis For basis	Bestell-Nr. / Order number	Bestell-Nr. / Order number		Bestell-Nr. / Order number
223.060.xxx	878.223.012	878.223.080		878.223.005

Wendeplattenhalter 90°

Insert holder 90°



- für die Verwendung auf Verlängerungskonsolen der Serien 221 und 224

- for use on extension bridges from series 221 and 224

Bestell-Nr. / Order number	Wendeplatte / Insert
225.000.009	CC .. 09 T3 ..
225.000.012	CN .. 12 04 ..
225.000.019	CN .. 19 06 ..

- Wendeplattenhalter werden paarweise geliefert

- insert holders will be supplied in pairs

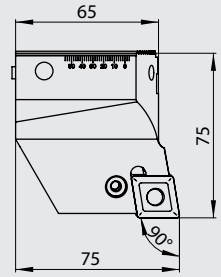

Wendeplattenhalter 90° axial 1.0mm zurückgesetzt

Insert holder 90° axial 1.0mm staggered



- für die Verwendung auf Verlängerungskonsolen der Serien 221 und 224

- for use on extension bridges from series 221 and 224

Bestell-Nr. / Order number	Wendeplatte / Insert
227.000.009	CC .. 09 T3 ..
227.000.012	CN .. 12 04 ..
227.000.019	CN .. 19 06 ..

- Wendeplattenhalter werden paarweise geliefert

- insert holders will be supplied in pairs



Wendeplattenhalter 70°

Insert holder 70°



- für die Verwendung auf Verlängerungskonsolen der Serien 221 und 224

- for use on extension bridges from series 221 and 224

Bestell-Nr. / Order number	Wendeplatte / Insert
229.000.019	CN .. 19 06 ..

- Wendeplattenhalter werden paarweise geliefert

- insert holders will be supplied in pairs

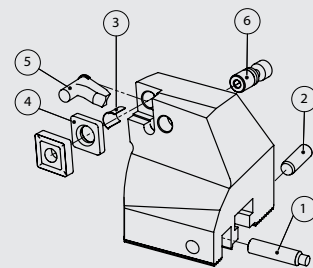
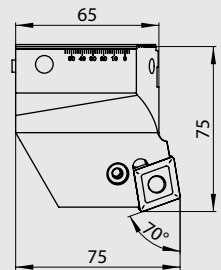

Ersatzteile / Zubehör

Spare parts / Accessories

225/229

Für Wendeplattenhalter	Bestell-Nr. / Order number	Bestell-Nr. / Order number	Bestell-Nr. / Order number	Bestell-Nr. / Order number
For insert holder	Einstellschraube / Adjustment screw ①	Stift / Pin ②	Torx-Schraube / Torx screw	Torx-Schlüssel / Torx driver
	225.000.009	865.224.230	865.225.024	843.009.000
	225.000.012	865.224.230	865.225.024	842.009.000
	225.000.019	865.224.230	865.225.024	
	229.000.019	865.224.230	865.225.024	
Für Wendeplattenhalter	Bestell-Nr. / Order number	Bestell-Nr. / Order number	Bestell-Nr. / Order number	Bestell-Nr. / Order number
For insert holder	Rohrstift / Hollow pin ③	Zwischenlage / Tip pad ④	Kniehebel / Lever ⑤	Schraube zu Kniehebel / Lever screw ⑥
	225.000.012	844.012.000	845.012.000	846.012.000
	225.000.019	844.019.000	845.019.000	846.019.000
	229.000.019	844.019.000	845.019.000	846.019.000

Feinbohrkopf

Fine boring head

230

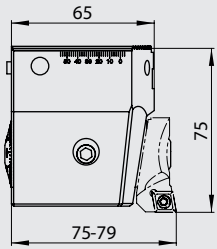

- für die Verwendung auf Verlängerungskonsolen der Serien 221 und 224
- Durchmessereinstellung mit geringstem Umkehrspiel
- Zustellgenauigkeit von 0.01mm im Durchmesser

- for use on extension bridges from series 221 and 224
- diametrical adjustment with maximal reduced reversal backlash
- 0.01mm diametrical adjustment

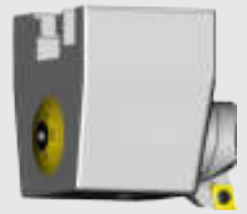

Bestell-Nr. / Order number	Wendeplattenhalter
230.000.000	254.550.006
	254.550.009

- Wendeplattenhalter müssen separat bestellt werden

- insert holder must be ordered separately

**Feinbohrkopf
DIGITAL**

**Fine boring head
DIGITAL**

231

- für die Verwendung auf Verlängerungskonsolen der Serien 221 und 224
- Einstellgenauigkeit 0.001mm im Durchmesser
- direktes Wegmeßsystem (kein Umkehrspiel)
- keine Batterie und Auswerteelektronik im Werkzeug verbaut
- sehr einfache Bedienung
- digital und analog einsetzbar

- for use on extension bridges from series 221 and 224
- 0.001 accuracy in diameter
- direct measurement system (no backlash)
- no battery and electronic evaluation unit inside the tool
- very easy operation
- for digital and analog use

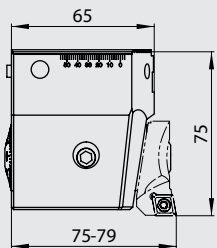

Bestell-Nr. / Order number	Wendeplattenhalter
231.000.000	254.550.006
	254.550.009

- Wendeplattenhalter müssen separat bestellt werden
- Anzeigeeinheit muss separat bestellt werden siehe Seite 6 (266.028.077).

- insert holder must be ordered separately
- Display unit must be ordered separately see page 6 (266.028.077).

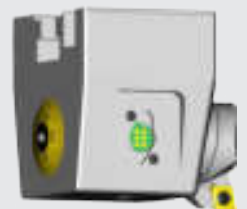

Gegengewicht

Counterweight

232

- zur Verwendung mit Feinbohrkopf der Serie 230/231

- for use with fine boring head from serie 230/231

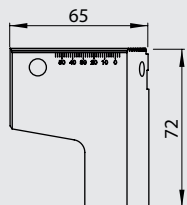

Bestell-Nr. / Order number
232.000.000



Ersatzteile / Zubehör

Spare parts / Accessories

230/231

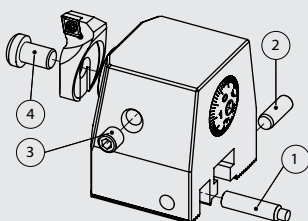

Für Feinbohrkopf For fine boring head	Bestell-Nr. / Order number	Bestell-Nr. / Order number	Bestell-Nr. / Order number	Bestell-Nr. / Order number
	1 Einstellschraube / Adjustment screw	2 Stift / Pin	3 Klemmschraube / Clamping screw	4 Befestigungsschraube / Fastening screw
230/231.000.000	865.224.230	865.225.024	881.230.000	880.252.550



Bestell-Nr. / Order number	System ø D	D1	D2	L1	L
322.550.006	55	6	25	27	42
322.550.008	55	8	28	27	42
322.550.010	55	10	35	30	45
322.550.012	55	12	42	35	50
322.550.014	55	14	45	35	50
322.550.016	55	16	48	35	50
322.550.018	55	18	50	35	50
322.550.020	55	20	52	35	50
322.550.025	55	25	55	-	65
322.720.032	72	32	72	-	80
322.720.040	72	40	80	-	85

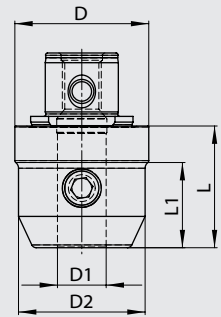

- Kühlmittelzufuhr entlang dem Werkzeugschaft für den Einsatz von Werkzeugen ohne Innenkühlung

- Spindle coolant is directed through three channels around the outside surface of the cutter, allowing use of milling cutters without inner coolant supply



Bestell-Nr. / Order number	System ø D	D1	D2	L1	L
323.550.006	55	6	25	26	42
323.550.008	55	8	28	26	42
323.550.010	55	10	35	29	45
323.550.012	55	12	42	34	50
323.550.014	55	14	44	34	50
323.550.016	55	16	48	34	50
323.550.018	55	18	50	34	50
323.550.020	55	20	52	41	57
323.550.025	55	25	55	-	65

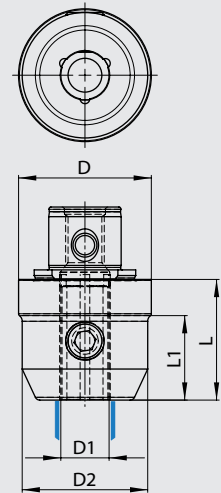

Ersatzteile / Zubehör

Spare parts / Accessories

322/323/332

Für Fräterspannfutter

For end mill adapter

Bestell-Nr. / Order number

Spannschraube / Clamping screw

3xx.550.006 890.322.006

3xx.550.008 890.322.008

3xx.550.010 890.322.010

3xx.550.012 890.322.012

3xx.550.014 890.322.012

3xx.550.016 890.322.016

3xx.550.018 890.322.016

3xx.550.020 890.322.020

3xx.550.025 890.322.025

3xx.xxx.032 890.322.032

3xx.xxx.040 890.322.040

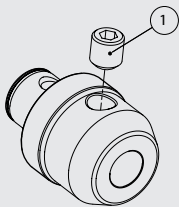

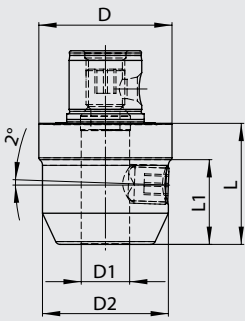

Bestell-Nr. / Order number	System ø D	D1	D2	L1	L
332.550.006	55	6	25	26	42
332.550.008	55	8	28	26	42
332.550.010	55	10	35	29	45
332.550.012	55	12	42	34	50
332.550.014	55	14	44	34	50
332.550.016	55	16	48	34	50
332.550.018	55	18	50	34	50
332.550.020	55	20	52	34	50
332.550.025	55	25	55	-	65
332.720.032	72	32	72	-	80
332.720.040	72	40	80	-	85

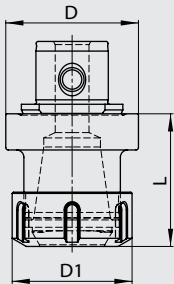

Bestell-Nr. / Order number	System ø D	D1	L	Spannzange / Collet	Spannbereich / Clamping range
342.250.016	25	22	35	ER 16	0.5-10
342.320.020	32	28	35	ER 20	1-13
342.550.025	55	42	50	ER 25	1-16
342.550.032	55	50	55	ER 32	2-20
342.550.040	55	63	62	ER 40	3-26
342.720.032	72	50	55	ER 32	2-20
342.720.040	72	63	62	ER 40	3-26

- Spannmuttern sind im Lieferumfang enthalten
- Schlüssel und Spannzangen müssen separat bestellt werden (siehe Preisliste)

- collet chucks will be supplied with clamping nuts
- keys and collets must be ordered separately (see price list)

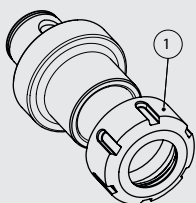

Für Fräterspannfutter For end mill adapter	Bestell-Nr. / Order number	Spannmutter / Clamping nut
342.250.016	895.342.016	
342.320.020	895.342.020	
342.550.025	895.342.025	
342.xxx.032	895.342.032	
342.xxx.040	895.342.040	

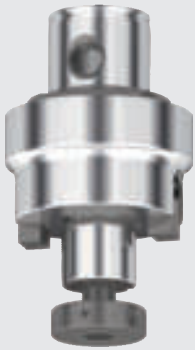

- mit Innenkühlung und Differenzialschraube

- with inner coolant supply and compensation screw

Bestell-Nr. / Order number	System ø D	D1	D2	L1	L
354.550.013	55	13	31	12	32
354.550.016	55	16	39	17	32
354.550.022	55	22	49	19	32
354.550.027	55	27	60	21	34
354.550.032	55	32	74	24	38
354.720.022	72	22	49	19	32
354.720.027	72	27	60	21	34
354.720.032	72	32	72	24	38
354.720.040	72	40	80	27	40

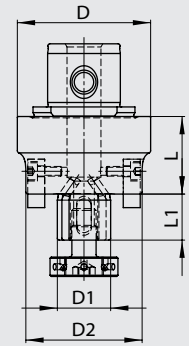

- mit Innenkühlung und Differenzialschraube

- with inner coolant supply and compensation screw

Bestell-Nr. / Order number	System ø D	D1	D2	L1	L
362.720.040	72	40	88	27	30
362.940.040	94	40	88	27	30

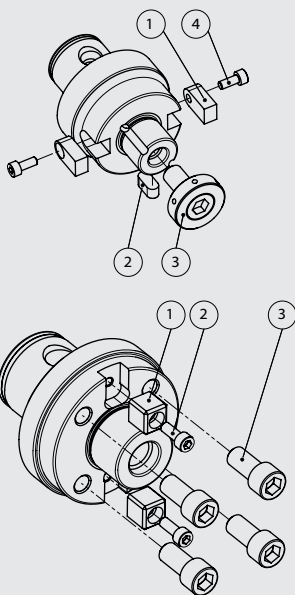
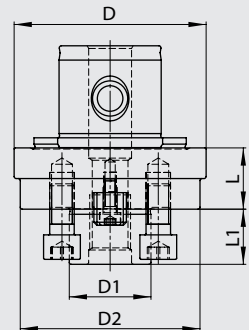

Ersatzteile / Zubehör

Spare parts / Accessories

354/362

Für Aufsteckfräsdorn For milling arbor	Bestell-Nr. / Order number	Bestell-Nr. / Order number	Bestell-Nr. / Order number	Bestell-Nr. / Order number
	Mitnehmerkeil / Drive lug ①	Passfeder / Splined key ②	Fräseranzugsschraube / Clamping screw ③	Schraube / Screw ④
354.xxx.013	900.352.013	902.352.013	904.352.013	905.352.308
354.xxx.016	900.352.016	902.352.016	904.352.016	905.352.308
354.xxx.022	900.352.022	902.352.022	904.352.022	905.352.410
354.xxx.027	900.352.027	902.352.027	904.352.027	905.352.512
354.xxx.032	900.352.032	902.352.032	904.352.032	905.352.616
354.xxx.040	900.352.040	902.352.040	904.352.040	905.352.618
Für Messerkopf- aufnahme For adapters for milling heads	Bestell-Nr. / Order number	Bestell-Nr. / Order number	Bestell-Nr. / Order number	Bestell-Nr. / Order number
	Mitnehmerstein / Drive lug ①	Schraube / Screw ②	Schraube / Screw ③	
362.xxx.040	810.212.362	811.210.212	812.210.212	

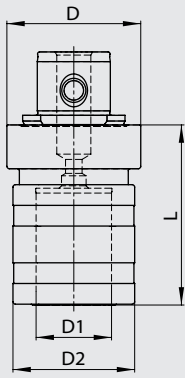

- für Maschinen mit synchronisiertem Gewindeschneiden
- innere Kühlmittelzuführung
- System Bilz
- for machines only with synchronised thread cutting feed
- with inner coolant supply
- System Bilz

Bestell-Nr. / Order number	System ø D	L	Gewindegröße / Thread size	D1	D2
396.320.115	32	46	M 3 – M 14	19	32
396.550.115	55	52	M 3 – M 14	19	32
396.550.225	55	74	M 6 – M 24	31	50
396.720.340	72	99	M 14 – M 36	48	72



Schnellwechseleinsätze

Quick-change adapter

- für Gewindebohrer DIN 371/376
- for screw tap DIN 371/376

Type 1

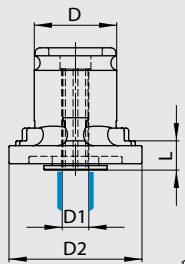

HIT

Type 2

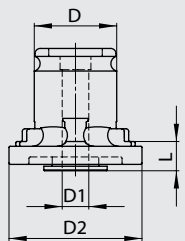

Type 1 Bestell-Nr. / Order number	Type 2 Bestell-Nr. / Order number	D ø / □	D1	D2	L
887.001.035	888.001.035	3.5 / 2.7	19	32	7
887.001.040	888.001.040	4.0 / 3.0	19	32	7
887.001.045	888.001.045	4.5 / 3.4	19	32	7
887.001.060	888.001.060	6.0 / 4.9	19	32	7
887.001.070	888.001.070	7.0 / 5.5	19	32	7
887.001.080	888.001.080	8.0 / 6.2	19	32	7
887.001.090	888.001.090	9.0 / 7.0	19	32	7
887.001.100	888.001.100	10.0 / 8.0	19	32	7
887.001.110	888.001.110	11.0 / 9.0	19	32	7
887.002.060	888.002.060	6.0 / 4.9	31	50	11
887.002.070	888.002.070	7.0 / 5.5	31	50	11
887.002.080	888.002.080	8.0 / 6.2	31	50	11
887.002.090	888.002.090	9.0 / 7.0	31	50	11
887.002.100	888.002.100	10.0 / 8.0	31	50	11
887.002.110	888.002.110	11.0 / 9.0	31	50	11
887.002.120	888.002.120	12.0 / 9.0	31	50	11
887.002.140	888.002.140	14.0 / 11.0	31	50	11
887.002.160	888.002.160	16.0 / 12.0	31	50	11
887.002.180	888.002.180	18.0 / 14.5	31	50	11





Bestell-Nr./ Order nr.	System ø D	L	L1	NL	DK	ø A min.	ø A max.	K	Z	G
772.550.015	55	42	30	26	14.0	16.0	26.0	SK	2	1
772.550.025	55	60	48	44	14.0	16.0	26.0	SK	2	2
772.550.035	55	76	64	60	14.0	16.0	26.0	HK	2	3
772.550.045	55	94	82	78	14.0	16.0	26.0	HK	2	4
772.550.115	55	46	34	30	15.6	19.6	30.0	SK	3	1
772.550.125	55	66	54	50	15.6	19.6	30.0	SK	3	2
772.550.135	55	85	73	69	15.6	19.6	30.0	HK	3	3
772.550.145	55	105	93	88	15.6	19.6	30.0	HK	3	4
772.550.155	55	125	113	108	15.6	19.6	30.0	HK	3	5
772.550.215	55	54	42	38	18.8	25.0	35.0	SK	3	1
772.550.225	55	78	66	63	18.8	25.0	35.0	SK	3	2
772.550.235	55	104	92	88	18.8	25.0	35.0	HK	3	3
772.550.245	55	128	116	113	18.8	25.0	35.0	HK	3	4
772.550.255	55	154	142	138	18.8	25.0	35.0	HK	3	5

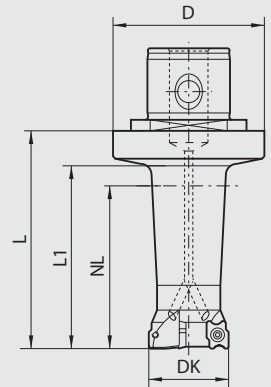

• Einsetzbare Wendeplatten
LCHT 06 03 00

ø A min. = Kleinster Bohrungs-
durchmesser

ø A max. = Grösster Bohrungs-
durchmesser ohne Vorboh-
ren

NL = max. Bearbeitungstiefe

DK = Bohr-Fräser-Kopfdurchmesser

Z = Zähnezahl

K = Kern (SK = Stahlschaft,
HK = Hartmetallkern)

G = Schaftlänge

• For use with Inserts LCHT 06 03 00

ø A min. = minimum boring
diameter

ø A max. = maximum boring diame-
ter without pre-boring



NL = maximum machining
depth

DK = Bore-Mill head diameter

Z = Number of teeth

K = Shaft type (SK = Steel
shaft, HK = Shaft with car-
bide insert)

G = Shaft type code

Bestell-Nummer	Wendeplatte	Schneidstoff	Technische Informationen	
Order number	Insert	Cutting mat.	Technical information	
600.820.006 600.820.009	LCHT 060300 LCHT 090400	FHF 	Mehrfach beschichtete feinstkorn Hartmetall-Wendeplatte zur Bearbeitung von allen Materialien bis HRc 42. Die Geometrie und die TiAlN-Beschichtung (Futura) ist optimal auf den Bohrfräser «Rambo» abgestimmt.	Bitte Zusatzkatalog mit Anwendungsempfehlungen verlangen! mbm_rambo.pdf
			Repeat coated fine grain carbide insert for machining of all materials up to 42 HRC. The TiAlN coating (Futura) and geometry of the insert is perfect for use in the «Rambo» Bore-Mill	For more information order the special leaflet! mbm_rambo.pdf
600.840.006 600.840.009	LCHT 060300 LCHT 090400	FHE 	Mehrfach beschichtete feinstkorn Hartmetall-Wendeplatte zur Bearbeitung von allen Materialien bis HRc 42. Die Geometrie und die TiAlN-Beschichtung (X.Treme) ist optimal auf den Bohrfräser «Rambo» abgestimmt.	Bitte Zusatzkatalog mit Anwendungsempfehlungen verlangen! mbm_rambo.pdf
			Repeat coated fine grain carbide insert for machining of all materials up to 42 HRC. The TiAlN coating (X.Treme) and geometry of the insert is perfect for use in the «Rambo» Bore-Mill	For more information order the special leaflet! mbm_rambo.pdf

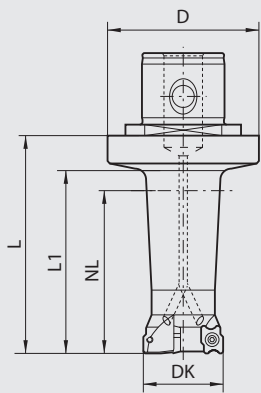

Bestell-Nr. / Order nr	System ø D	L	L1	NL	DK	ø A min.	ø A max.	K	Z	G
772.550.315	55	62	50	45	23.0	30.0	46.0	SK	3	1
772.550.325	55	92	80	75	23.0	30.0	46.0	SK	3	2
772.550.335	55	122	110	105	23.0	30.0	46.0	HK	3	3
772.550.345	55	152	140	135	23.0	30.0	46.0	HK	3	4
772.550.355	55	182	170	165	23.0	30.0	46.0	HK	3	5
772.550.415	55	79	67	60	28.0	40.0	56.0	SK	3	1
772.550.425	55	116	104	100	28.0	40.0	56.0	SK	3	2
772.550.435	55	156	144	140	28.0	40.0	56.0	HK	3	3
772.550.445	55	196	184	180	28.0	40.0	56.0	HK	3	4
772.550.455	55	236	224	220	28.0	40.0	56.0	HK	3	5
772.550.510	55	56	44	40	33.0	50.0	66.0	SK	3	1
772.720.515	72	92	80	75	33.0	50.0	66.0	SK	3	2
772.720.525	72	142	130	125	33.0	50.0	66.0	SK	3	3
772.720.535	72	192	180	175	33.0	50.0	66.0	HK	3	4
772.550.610	55	66	54	50	38.0	60.0	76.0	SK	4	1
772.720.615	72	106	94	90	38.0	60.0	76.0	SK	4	2
772.720.625	72	166	154	150	38.0	60.0	76.0	SK	4	3
772.720.635	72	226	214	210	38.0	60.0	76.0	HK	4	4
772.550.710	55	76	64	60	44.0	72.0	88.0	SK	5	1
772.720.715	72	125	113	108	44.0	72.0	88.0	SK	5	2
772.720.720	72	160	148	144	44.0	72.0	88.0	SK	5	3
772.720.725	72	196	184	180	44.0	72.0	88.0	SK	5	4
772.550.810	55	86	74	70	50.0	84.0	100.0	SK	6	1
772.720.815	72	142	130	126	50.0	84.0	100.0	SK	6	2
772.720.820	72	184	172	168	50.0	84.0	100.0	SK	6	3
772.720.825	72	226	214	210	50.0	84.0	100.0	SK	6	4



• Einsetzbare Wendeplatten
LCHT 09 04 00

• For use with Inserts LCHT 09 04 00

ø A min. = Kleinster Bohrungsdurchmesser

ø A min. = minimum boring diameter

ø A max. = Grösster Bohrungsdurchmesser ohne Vorbohren

ø A max. = maximum boring diameter without pre-boring

NL = maximum machining depth

NL = max. Bearbeitungstiefe

DK = Bore-Mill head diameter

DK = Bohr-Fräser-Kopfdurchmesser

Z = Number of teeth

Z = Zähnezahl

K = Shaft type (SK = Steel shaft, HK = Shaft with carbide insert)

K = Kern (SK = Stahlschaft, HK = Hartmetallkern)



















G = Schaftlänge

G = Shaft type code





Ersatzteile / Zubehör

Spare parts / Accessories

Für Bohr-Fräser	Bestell-Nr. / Order number	Bestell-Nr. / Order number
For Bore-Mill	Torx-Dreher / Torx driver	Torx-Schraube / Torx screw
772.550.015-255	842.106.000	843.006.000
772.550.315-772.720.825	842.108.000	843.030.000

Bestell-Nummer	Wendeplatte	Schneidstoff	Technische Informationen	Materialien	v [m/min]	f [mm/Z]
Order number	Insert	Cutting mat.	Technical information	Materials	v [m/min]	f [mm/r]
600.050.022	WCMT 020102 	CTU 	Cermet-Wendeplatte (Titan-Carbid / Titan-Nitrid) für Feinbohrarbeiten mit hoher Schnittgeschwindigkeit und gleichmässigem Aufmass.	Stahl Grauguss Aluminium	50–300 50–300 bis 800	0.04 bis 0.10
			Titanium carbide / titanium nitride (Cermet) for fine bore machining with high cutting speed and regular cutting depth.	Steel Cast Iron Aluminium	50–300 50–300 to 800	0.04 to 0.10
600.060.022	WCGT 020102 	HUP 	Unbeschichtete Hartmetall-Wendeplatte , allseitig geschliffen mit grossem Spanwinkel für Feinbohrarbeiten. Die Wendeplatte eignet sich insbesondere bei kleinem Aufmass und langen Bohrungen.	Stahl Stahl rostfrei Grauguss Aluminium	50–250 30–200 50–300 bis 800	0.04 bis 0.10
			Uncoated Carbide insert, ground all around with large rake angle for fine bore cutting. The insert is particularly good for small cutting depth in deep bores.	Steel Stainless steel Cast iron Aluminium	50–250 30–200 50–300 to 800	0.04 to 0.10
600.070.022	WCGT 020102 	SFH 	Mehrfach beschichtete superfeinstkorn Hartmetall-Wendeplatte zur Bearbeitung von harten und gehärteten Werkstoffen bis 62 HRc . Die Wendeplatte eignet sich hervorragend für Feinbohrarbeiten in gehärtetem Stahl als Alternative zum K-Schleifen.	Stahl weich	bis 300	0.04
600.070.024	WCGT 020104 			Stahl HRC 45 Stahl HRC 50 Stahl HRC 55 Stahl HRC 60 Stahl HRC 62	80–250 80–200 50–150 30–100 20– 60	bis 0.20
			Repeat coated extremely fine grain carbide insert for machining of hard and hardened steels up to 62 HRc . Very suitable for fine boring of precision bores in hardened steel as an alternative to Jig-grinding.	Steel soft Steel HRC 45 Steel HRC 50 Steel HRC 55 Steel HRC 60 Steel HRC 62	bis 300 80–250 80–200 50–150 30–100 20– 60	0.04 to 0.20
600.200.062	CCMT 060202 	CTU 	Cermet-Wendeplatte (Titan-Carbid / Titan-Nitrid) für niedrige bis hohe Schnittgeschwindigkeiten beim Schlichten mit gleichbleibendem Aufmass. Auch für leichte Schrupparbeiten einsetzbar. Bester Widerstand gegen Verschleiss und Schneidkantendeformation. Geeignet für Feinbohrarbeiten mit normalem Aufmass von 0.25 mm im Durchmesser.	Stahl	50–300	0.08
600.200.064	CCMT 060204 			Stahl rostfrei	30–250	bis
600.200.092	CCMT 09T302 			Grauguss	50–300	0.15
600.200.094	CCMT 09T304 			Aluminium	bis 800	
600.200.098	CCMT 09T308 			Buntmetall	bis 500	
600.200.128	CCMT 120408 					
			Titanium carbide / titanium nitride (Cermet) for finishing with low to high cutting speeds with regular cutting depth. Also for light roughing. High resistance to wear and tip deformation. Suitable for fine boring with normal cutting depths from 0.25 mm in bored diameter.	Steel Stainless steel Cast iron Aluminium Copper alloys	50–300 30–250 50–300 to 800 to 500	0.08 to 0.15
600.850.062	CCGT 060202L 	ICH 	Hochwiderstandsfähig gegen Brüche durch die besondere Zusammensetzung des Basismaterial plus der speziellen TICN-Beschichtung. Sehr hohe mechanische Stabilität und Verschleissbeständigkeit. Sehr gut geeignet für unterbrochenen Schnitt.	Stahl weich	bis 300	0.04
600.850.064	CCGT 060204L 			Stahl HRC 45	80–250	to
600.850.094	CCGT 09T304L 			Stahl HRC 50 Stahl HRC 55 Stahl rostfrei Grauguss	80–200 50–150 30–200 50–300	0.20
			Excellent toughness and wear resistance due to the special composition of the base material plus the special TICN coating. Very suitable for interrupted cuts	Steel soft Steel HRC 45 Steel HRC 50 Steel HRC 55 Stainless steel Cast iron	bis 300 80–250 80–200 50–150 30–200 50–300	0.04 to 0.20

HIT
HRC+

Bestell-Nummer	Wendeplatte	Schneidstoff	Technische Informationen	Materialen	v [m/min]	f [mm/Z]
Order number	Insert	Cutting mat.	Technical information	Materials	v [m/min]	f [mm/r]
600.300.062	CCGT 060202L ○	CTG	 <p>Allseitig geschliffene, hochpositive Cermet-Wendeplatte (Titan-Carbid / Titan-Nitrid), für alle Feinbohrarbeiten. Die Wendeplatte eignet sich insbesondere bei kleinem Aufmass und langen Bohrungen. Durch den grossen Spanwinkel sind die Druck- und Schnittkräfte sehr gering.</p>	Stahl	50–300	0.06
600.300.064	CCGT 060204L ○			Stahl rostfrei	30–250	bis
600.300.092	CCGT 09T302L ○			Grauguss	50–250	0.12
600.300.094	CCGT 09T304L ○			Aluminium Buntmetall	bis 800 bis 500	
			<p>HIT</p> <p>All ground, Cermet insert with highly positive rake angle for all fine bore machining. Very suitable for deep bores with small cutting depth. Low cutting and pressing forces due to large rake angle.</p>	Steel Stainless steel Cast iron Aluminium Copper alloys	50–300 30–250 50–250 to 800 to 500	0.06 to 0.12
600.800.062	CCGT 060202L ○	SFH	 <p>Mehrfach beschichtete superfeinkorn Hartmetall-Wendeplatte zur Bearbeitung von harten und gehärteten Werkstoffen bis 62 HRC. Die Wendeplatte eignet sich hervorragend für Feinbohrarbeiten in gehärtetem Stahl als Alternative zum K-Schleifen.</p>	Stahl weich	bis 300	0.04
600.800.064	CCGT 060204L ○			Stahl HRC 45	80–250	bis
600.800.092	CCGT 09T302L ○			Stahl HRC 50	80–200	0.20
600.800.094	CCGT 09T304L ○			Stahl HRC 55 Stahl HRC 60 Stahl HRC 62	50–150 30–100 20– 60	
			<p>HIT HRC+</p> <p>Repeat coated extremely fine grain carbide insert for machining of hard and hardened steels up to 62 HRC. Very suitable for fine boring of precision bores in hardened steel as an alternative to Jig-grinding.</p>	Steel soft Steel HRC 45 Steel HRC 50 Steel HRC 55 Steel HRC 60 Steel HRC 62	bis 300 80–250 80–200 50–150 30–100 20– 60	0.04 to 0.20
600.400.064	CCMT 060204 ●	HBH	  <p>Mehrfach beschichtete Hartmetall-Wendeplatte mit hoher Verschleissfestigkeit und grossem Widerstand gegen plastische Verformung. Generell geeignet für die Stahlbearbeitung mit mittleren bis hohen Schnittgeschwindigkeiten.</p>	Stahl	20–280	0.10
600.400.094	CCMT 09T304 ●			Stahl rostfrei	30–250	bis
600.400.098	CCMT 09T308 ●			Grauguss	50–250	0.40
600.401.128	CCMT 120408 ●			Sphäroguss	50–180	
600.400.128	CNMG 120408 ●			Aluminium	bis 800	
600.400.168	CNMG 160608 ●			Buntmetall	bis 500	
600.400.169	CNMG 160612 ●					
600.400.198	CNMG 190612 ●					
600.400.199	CNMG 190616 ●					
			<p>Repeat coated carbide insert with high wear and plastic deformation resistance. Generally used for machining of ferrous steels with middle to high cutting speeds.</p>	Steel Stainless steel Cast iron Spheroidal cast iron Aluminium Copper alloys	20–280 30–250 50–250 50–180 to 800 to 500	0.10 to 0.40
600.500.128	CNMM 120408 ●	HBZ	 <p>Mehrfach beschichtete Hartmetall-Wendeplatte mit höchster Zähigkeit und Stabilität der Schneidekante. Geeignet für Stahlbearbeitung durch die positive Schneidegeometrie auch bei unterbrochenem Schnitt.</p>	Stahl	50–300	0.10
600.500.168	CNMM 160608 ●			Stahl rostfrei	30–250	bis
600.500.169	CNMM 160612 ●			Grauguss	50–300	0.60
600.500.198	CNMM 190612 ●			Sphäroguss	50–200	
600.500.199	CNMM 190616 ●			Aluminium Buntmetall	bis 800 bis 500	
			<p>Repeat coated carbide insert, very tough with high stability cutting edge. Suitable for machining of ferrous steels also with interrupted cut due to its positive cutting geometry.</p>	Steel Stainless steel Cast iron Spheroidal cast iron Aluminium Copper alloys	50–300 30–250 50–300 50–200 to 800 to 500	0.10 to 0.60

The background of the entire page is a light blue technical drawing. It features various mechanical components, including a central rectangular block with a grid pattern, a ruler with markings from 10 to 70, and various bolts and nuts. The drawing is composed of white lines on a blue background.

SWISS  **TOOLS**® Swiss Tool Systems AG
Wydenstrasse 28
CH-8575 Bürglen
Phone +41 (0)71 634 85 20
Fax +41 (0)71 634 85 29
www.swisstools.org